

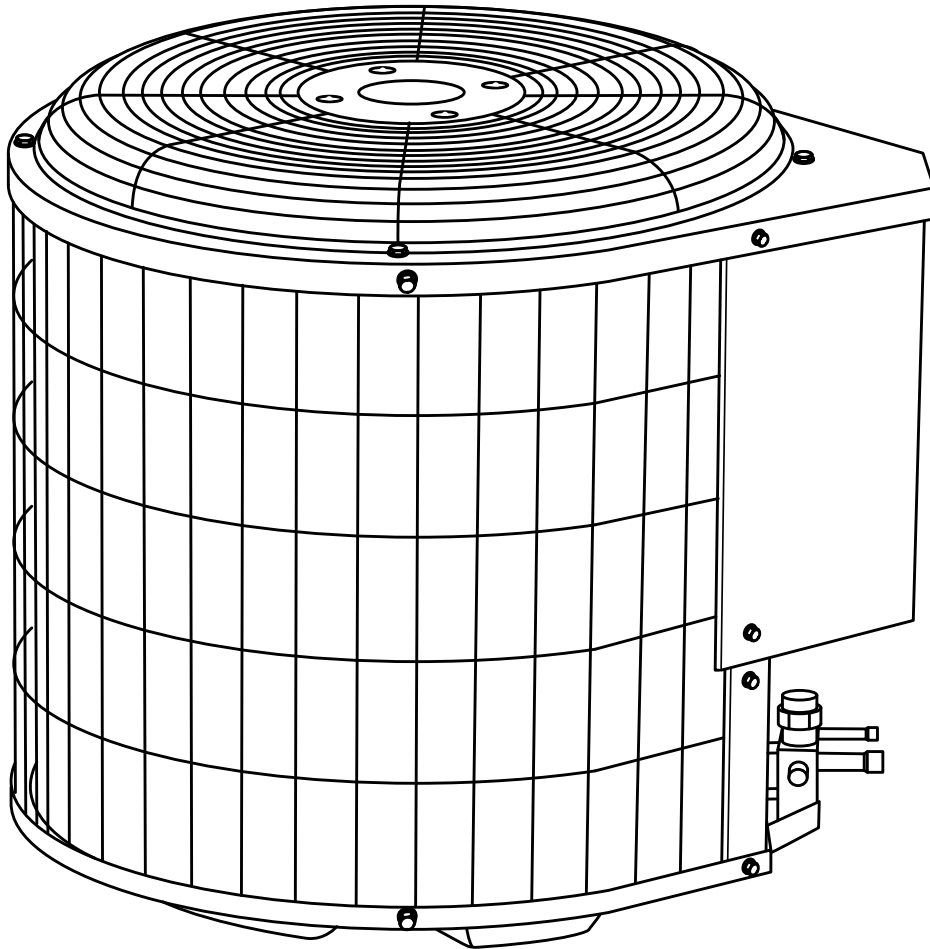

Heating & Cooling

Heat Pump

**USER'S INFORMATION MANUAL
FOR THE OPERATION AND
MAINTENANCE OF YOUR NEW
RESIDENTIAL HEAT PUMP**



**NOTE TO INSTALLER:
THIS MANUAL MUST BE LEFT WITH
THE EQUIPMENT USER.**

WELCOME TO EFFICIENT YEAR-ROUND COMFORT

Congratulations on your excellent choice and sound investment in year-round home comfort!

Your new heat pump represents both the latest in engineering development and the culmination of many years of experience from one of the most reputable manufacturers of comfort systems.

Your new unit is among the most energy-efficient and reliable heat pump products available today. To assure its dependability, spend just a few minutes with this booklet now. Learn about the operation of your heat pump, and the small amount of maintenance it takes to keep it operating at its peak efficiency.

With minimal care, your new heat pump will provide you and your family with year-round home comfort—both now and for years to come.

Safety Considerations

Recognize safety information. This is the safety-alert symbol . When you see this symbol on the unit and in instructions or manuals, be alert to the potential for personal injury.

Understand the signal words DANGER, WARNING, and CAUTION. These words are used with the safety-alert symbol. DANGER identifies the most serious hazards which **will** result in severe personal injury or death. WARNING signifies hazards which **could** result in personal injury or death. CAUTION is used to identify unsafe practices which **would** result in minor personal injury or product and property damage.

 WARNING: Improper installation, adjustment, alteration, service, maintenance or use can cause explosion, fire, electrical shock, or other conditions which may cause personal injury or property damage. Consult a qualified installer, service agency, or your distributor or branch for information or assistance. The qualified installer or agency must use factory-authorized kits or accessories when modifying this product.

 WARNING: To prevent personal injury, death, or property damage read and follow all instructions and warnings, including labels shipped with or attached to unit before operating your new heat pump.

YOUR COMFORT SYSTEM

Identifying Your System

Take the time to familiarize yourself with the type of system you have. This knowledge will be of use in understanding the basic operation of your new heat pump.

The split-system type has an indoor and an outdoor unit, each of which contains a coil. These units are interconnected by refrigerant tubes. (See Fig. 1.)

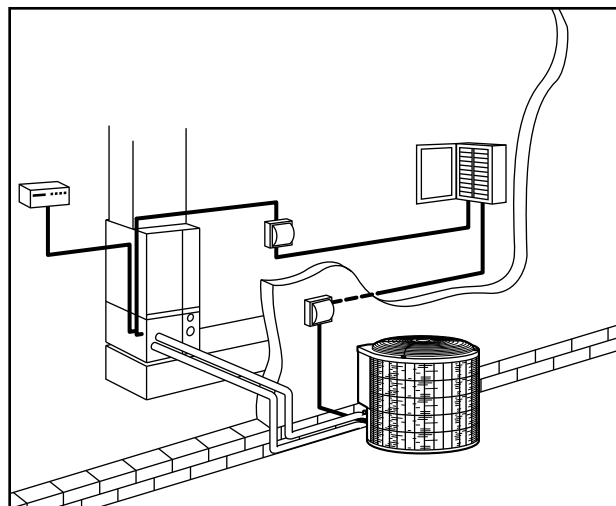

Fig. 1—Typical Split-System Installation

Each unit has a rating plate affixed to it which provides necessary information for specific identification of a unit. You should familiarize yourself with the product, model, and serial numbers listed on each rating plate.

IMPORTANT FACTS

To better protect your investment and to eliminate unnecessary service calls, familiarize yourself with the following facts:

- Your heat pump system should never be operated without a clean air filter properly installed. Plan to inspect the filter periodically. A clogged air filter will increase operating costs and shorten the life of the unit.
- Supply-air and return-air registers should not be blocked. Drapes, furniture, and toys are some of the items commonly found obstructing grilles. Restricted airflow lessens the unit's efficiency and life span.
- The outdoor unit must have unrestricted airflow. Do not cover the unit, lean anything against it, or stand upon it. Do not allow grass clippings, leaves, or other debris to accumulate around or on top of the unit. Maintain a 12-in. minimum clearance between the outdoor unit and tall grass, vines, shrubs, etc.
- Your multipurpose indoor thermostat is the control center for your heat pump system. You should familiarize yourself with its proper operation. Attempting to control the system by other means—for instance, switching the electrical supply power ON and OFF—may cause damage to the unit.
- During heating, increasing the thermostat more than 2 degrees may cause the supplemental heaters to be turned on to satisfy the thermostat. Needless use of the supplementary heat reduces potential energy savings.
- You may find that you can maintain greater personal comfort by running the fan continuously. Air pockets can form due to the structure of the house, placement of registers, etc. These air pockets may be too cool or warm for your liking. Continuous fan operation minimizes any temperature differences. Also, systems equipped with electronic air cleaners and/or humidifiers offer the added benefits of having the air continuously cleaned year-round, and humidified during the winter season.
- Your heat pump will remove humidity from your home during the cooling season. After a few minutes of operation, you should be able to see water trickle from the condensate drain of the indoor cooling coil. Check this occasionally to be sure the drain system is not clogged. Of course, don't expect to see much drainage if you live in a very dry environment.
- During the heating cycle, air from your registers may seem cool. This is because the air is being delivered at a higher velocity and a more constant flow than air supplied by a conventional furnace. Also, your heat pump supplies air at 85° to 90°F instead of in sudden bursts of hot air as with a conventional furnace. The air may feel cool because it is slightly lower than your body temperature. However, it is sufficiently warm to keep you comfortable.
- Ice or frost will tend to form on the outdoor coil during the winter heating operation. Your heat pump is designed to automatically melt the ice. When in this defrost cycle, it is normal for steam or fog to rise from the outdoor unit. Do not be alarmed!

OPERATING YOUR HEAT PUMP

The operation of your heat pump system is controlled by the indoor thermostat. (See Fig. 2.) You simply adjust the thermostat and it maintains the indoor temperature at the level you select.

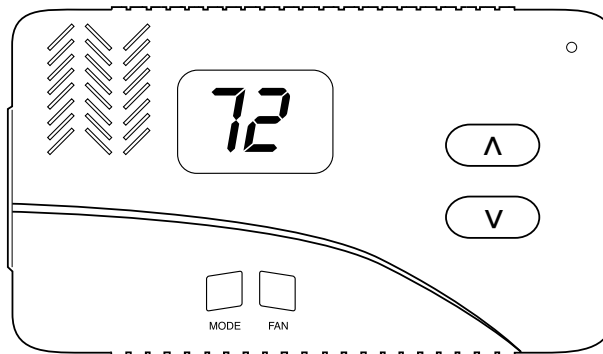

Fig. 2—Typical Thermostat

Some thermostats possess two temperature control settings: one for setting the temperature desired during the cooling cycle, and one for setting the temperature desired during the heating cycle.

The FAN button offers two options for controlling the blower: AUTO and ON. When set to AUTO, the blower will run during the time the heat pump is operating. When the FAN is set to ON, the blower will run continuously.

Typically, your thermostat offers the following selections: COOL, OFF, and HEAT. Your thermostat may also have a fourth selection, AUTO. The heat pump will not operate if OFF is selected. If COOL is selected, your heat pump will operate in its cooling mode when the indoor temperature rises above the level that you wish to maintain. If HEAT is selected, your heat pump will provide warmth whenever the indoor temperature falls below the level that you have selected.

The AUTO selection found on some thermostats provides for automatic changeover between cooling and heating cycles. With AUTO selected, the cooling mode is activated when the indoor temperature rises above the thermostat cooling temperature setting, or the heating mode will be activated when the indoor temperature drops below the thermostat setting for the heating cycle.

Depending on your typical winter heating needs, your home comfort system may include a supplementary heating source. The EMERGENCY HEAT mode provides for convenient selection between the two heating appliances.

In certain geographic areas and in certain applications, electric heat is not required. Any questions regarding your application should be directed to your dealer.

COOLING CYCLE

When operating in the cooling mode, your heat pump will run until the indoor temperature is lowered to the level you have selected. On extremely hot days, your conditioner will run for longer periods at a time and have shorter off periods than on moderate days.

The following are typical conditions that add extra heat and/or humidity to your home. Your cooling unit will work longer to keep your home comfortable under these conditions:

- Entrance doors are frequently opened and closed
- Laundry appliances are being operated
- A shower is running
- More than the usual number of people are present in the home
- More than the normal number of electric lights are in use
- Drapes are open on the sunny side of the home

HEATING CYCLE

With HEAT selected, the heating section of your home comfort system will operate until room temperature is raised to the level you have selected. Of course, the heating unit will have to operate for longer periods to maintain a comfortable environment on cooler days and nights than on moderate ones.

Refer to your furnace User's Manual for specific information on heating operation.

DEFROST CYCLE

When your heat pump is providing heat to your home and the outdoor temperature drops below 45°F, moisture may begin to freeze on the surface of the outdoor coil. If allowed to build up, this ice would impede airflow across the coil and reduce the amount of heat absorbed from the outside air. So, to maintain energy-efficient operation, your heat pump has an automatic defrost cycle.

The defrost cycle starts at a preset time interval of 90 minutes, although, it may be reset to either 30 or 50 minutes. Defrost will start at the preset time only if the ice is sufficient to interfere with normal heating operation.

After the ice is melted from the outdoor coil, or after a maximum of 10 minutes in the defrost mode, the unit will automatically switch back to normal heating operation.

Do not be alarmed if steam or fog appears at the outdoor unit during the defrost cycle. Water vapor from the melting ice may condense into a mist in the cold outside air.

During certain weather conditions such as heavy snow and freezing rain it is not uncommon for ice to build up on the outdoor unit grille. This is normal for these weather conditions. Do not attempt to remove the ice from the outdoor unit grille. This condition will not affect the proper function of the unit and will clear within a few days.

EMERGENCY HEAT

The EMERGENCY HEAT setting on your thermostat refers to any supplementary heating appliance that may be included in your home comfort system. Operation of the EMERGENCY HEAT source may be required if heating demands exceed the capacity of the heat pump, or if the heat pump malfunctions.

The red light on your thermostat will illuminate if the EMERGENCY HEAT switch is moved from NORMAL to the EMERGENCY HEAT setting. This indicates that the heat pump is off and the supplemental heating appliance is selected for operation.

Also, if your particular model of heat pump includes an efficiency alarm circuit, the red light will glow if the compressor malfunctions. Call your dealer for immediate service if you suspect trouble.

During the heating season, switch to EMERGENCY HEAT if the electricity to your outdoor unit has been off for more than 30 minutes for any reason (i.e., power outage). Leave the switch in the EMERGENCY HEAT mode for an amount of time equal to that during which the power was off. It isn't necessary to exceed 12 hours. If you cannot determine how long the power has been off, leave the switch in the EMERGENCY HEAT position for 8 hours.

NOTE: The EMERGENCY HEAT switch is effective only when HEAT or AUTO is selected.

PERFORMING ROUTINE MAINTENANCE

With the proper maintenance and care, your heat pump unit will operate economically and dependably. Maintenance can be accomplished easily by referring to the following directions. However, before performing maintenance, consider these important safety precautions.

⚠ WARNING: Disconnect all electrical power to the heat pump before removing access panels to perform maintenance. Disconnect power to both the indoor and outdoor units. Note: There may be more than 1 electrical disconnect switch. Electric shock can cause personal injury or death.

⚠ CAUTION: Although special care has been taken to minimize sharp edges in the construction of your unit. Be extremely careful when handling parts or reaching into the unit.

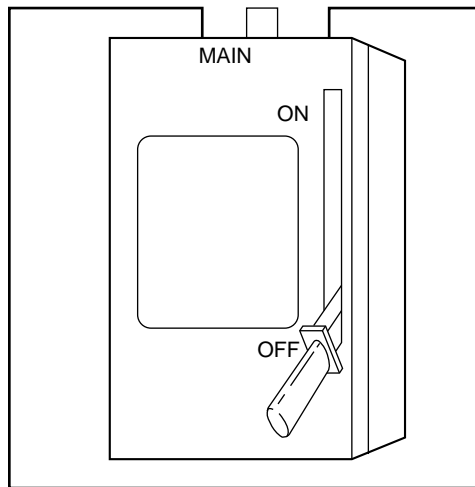

Fig. 3—Main Electrical Disconnect

CHECK THE AIR FILTER

A dirty air filter will cause excessive strain on the compressor and blower motor. This can cause the components to overheat and automatically shut down. In the extreme, the components will fail and need to be replaced. To avoid inefficient or failed operation of your unit, **CHECK THE FILTER(S) EVERY 3 TO 4 WEEKS**. Replace filter(s) when necessary, or clean the filter(s) if you have the washable type.

Disposable filters should be replaced by similar, new filters of the same dimensions.

Reusable, washable filters should be washed in a solution of cold water and mild detergent, then rinsed and thoroughly dried. **THE FILTER MUST BE COMPLETELY DRY BEFORE BEING REINSTALLED**. To avoid prolonged shutdown of your unit while a filter is drying, you should have an extra filter on hand. This would allow you to rotate between the two filters with minimal downtime for your comfort system. Extra filters may be purchased from your dealer.

There are no filters in the outdoor unit of a split system. If your indoor unit is a gas or oil furnace, refer to your furnace User's Manual for filter location and procedures for replacement or cleaning.

If your system includes an indoor fan coil unit, the filter may be located in the unit where it connects with the return-air duct or plenum. (See Fig. 4.) Remove the filter cover plate by sliding latches toward center of plate. Lift filter to clear lower flange. Filter is spring-loaded and will pop out. Reinstall filter, being certain to secure filter behind lower flange. When reinstalling cover plate, secure plate behind upper flange then slide tabs outward.

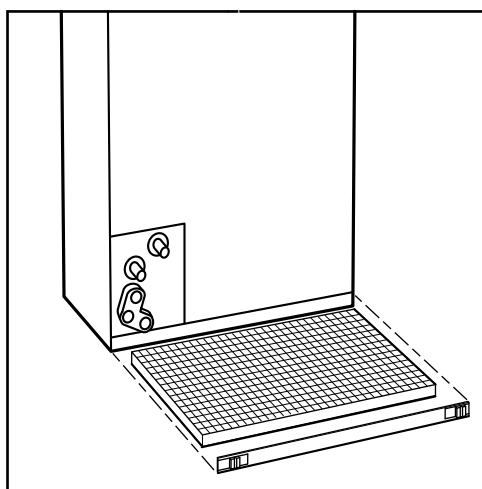

**Fig. 4—Removing Filter
from Fan Coil Unit**

The indoor fan coil unit may be located in the attic. In this instance the filter may be located behind the return air grille. Access the filter by removing the return air grille.

INDOOR COIL

If the split-system coil has only been operated with a clean filter in place, it should require minimal cleaning. You may use a vacuum cleaner and soft brush attachment to remove any accumulation of dust from the top and underside of the finned coil surface. However, perform this maintenance only when the coil is completely dry.

If you cannot get the coil clean by this method, call your dealer for service. It may be necessary to clean the coil with a detergent solution and rinse it with water. This could require the removal of the coil. You should not attempt this yourself.

OUTDOOR COIL

If grass clippings, leaves, shrubbery, and debris are kept away from the outdoor unit, minimal care should be sufficient to keep the system functioning properly. For proper drainage, debris must be removed periodically from the base pan. However, if the outdoor coil becomes dirty, use a brush or vacuum cleaner and soft brush attachment to clean the exterior surface. If dirt is deep in the coil, contact your dealer for service. The outdoor fan motor may have to be disconnected and the top panel removed to gain access to the coil for thorough cleaning. Do not attempt this yourself.

OUTDOOR COIL—SEA COAST

If your unit is located near the ocean, special maintenance is required. Ocean mist/breeze carries salt, which is corrosive to most metals. Although your new unit is made out of galvanized metal and is protected by top-grade paint, you should take the precaution of additional maintenance which consists of periodically washing the unit. By washing all exposed surfaces and coil, you will be adding additional life to your unit. Please consult your installing contractor for proper intervals/procedures for your geographic area or service contact.

UNIT SUPPORT

Your split-system outdoor unit should be maintained at a level position. If its support should shift or settle so that the unit is no longer level, you should correct the condition. Relevel it promptly to assure condensate drainage out of the unit. If you notice that water or ice collects beneath the unit, arrange for it to be drained away from the unit.

BEFORE YOU REQUEST A SERVICE CALL

BEFORE YOU CALL FOR SERVICE, CHECK FOR THESE EASILY SOLVED PROBLEMS:

- Check the indoor and outdoor disconnect switches. Verify that circuit breakers are ON or that fuses have not blown.
- Check for sufficient airflow. Check the air filter(s) for any accumulations of dirt. Check for blocked return-air or supply-air grilles. Be sure grilles are open and unobstructed.
- Check the settings on your indoor thermostat. If you desire cooling, see that the temperature setting is set below room temperature and COOL or AUTO is selected. If you require warmth, be sure the temperature setting is set above room temperature and HEAT or AUTO is selected. The FAN switch should be set at ON for continuous blower operation or AUTO if you wish the blower to function only while the unit is operating.

If your comfort system still fails to operate, contact your servicing dealer for troubleshooting and repairs. Specify your apparent problem, and state the model and serial numbers of your equipment. With this information, your dealer may be able to offer helpful suggestions over the phone or save valuable time through knowledgeable preparation for the service call.

REGULAR DEALER MAINTENANCE

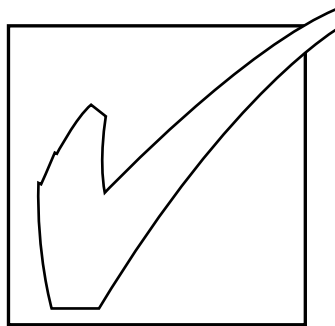

In addition to the routine maintenance that you perform, your home comfort system should be inspected regularly by a properly trained service technician. The inspection (preferably twice each year, but at least once every year) should include the following:

- Routine inspection of air filter(s). Replacement or cleaning as required.
- Inspection and cleaning of the blower wheel, housing, and motor as required.
- Inspection and, if required, cleaning of indoor and outdoor coils.
- Inspection of the indoor coil drain pan, plus the primary and secondary drain lines. If supplied, the auxiliary drain pan and line should be inspected at this time. Service should include cleaning if required.
- A check of all electrical wiring and connections.
- A check for secure physical connections of individual components within units.
- Operational check of the heat pump system to determine actual working condition. Necessary repair and/or adjustment should be performed at this time.

Your servicing dealer may offer an economical service contract that covers seasonal inspections. Ask for further details.

FOR THE RECORD

Record the model, product, and serial numbers of your new equipment in the spaces provided. This information, along with the other ready-reference facts requested, will be necessary should you ever require information or service.

INSTALLATION DATA

Date Installed _____
Dealer Name _____
Address _____
City _____
State _____ Zip _____
Telephone _____

SPLIT-SYSTEM

OUTDOOR UNIT:

Product No. _____
Model No. _____
Serial No. _____

INDOOR UNIT OR COIL:

Product No. _____
Model No. _____
Serial No. _____

MODULAR INDOOR UNIT, if Applicable:

Blower—Product No. _____
Model No. _____
Serial No. _____

Coil—Product No. _____
Model No. _____
Serial No. _____

Heater—Product No. _____
Model No. _____
Serial No. _____

