

HS21 Air Conditioner

Congratulations on the purchase of your Lennox HS21 air conditioner. Lennox takes pride in manufacturing high quality products that keep you comfortable while saving you energy and money.

The HS21 is a high efficiency air conditioner equipped with energy- -saving two speed compressors designed to operate for long periods of time at low speed. As the outside air temperature increases, the compressor will switch to high speed.

This booklet explains the complete air conditioning system, how to identify the unit's model number, how to operate a typical thermostat, and how to maintain the unit for optimum performance. Keep this booklet and the warranty shipped with the air conditioner for future reference.

Thank you again for choosing Lennox.

HOW THE COOLING SYSTEM WORKS

The heating and cooling system consists of an air conditioner, in this case the HS21, and an indoor unit. The indoor unit may be an electric, gas or oil furnace. If your system is set up for cooling only, the indoor unit consists of a blower and evaporator coil. An electric furnace consists of a blower and evaporator coil section along with electric strip heat. Oil or gas- -fired furnaces are equipped with a blower and heat exchanger and will have an evaporator coil to complete the cooling circuit. The indoor unit's evaporator coil is connected to the HS21 air conditioner with refrigerant lines.

The cooling cycle starts when the thermostat senses that cooling is needed. The air conditioner receives a signal from the thermostat and the compressor pumps refrigerant through the air conditioner's coils. The fan on the HS21 pulls air over the coils which cools the refrigerant. The refrigerant flows under pressure to the indoor unit's evaporator coil. There, pressure is released and the refrigerant makes the evaporator coil very cold. Air from the indoor unit blower is cooled as it is pulled across the cold coil and water is removed from the air for dehumidification. The air then travels through the duct system to each room. The refrigerant travels back to the air conditioner outside. At this point the cooling cycle starts over again and will continue until the thermostat setting has been reached.

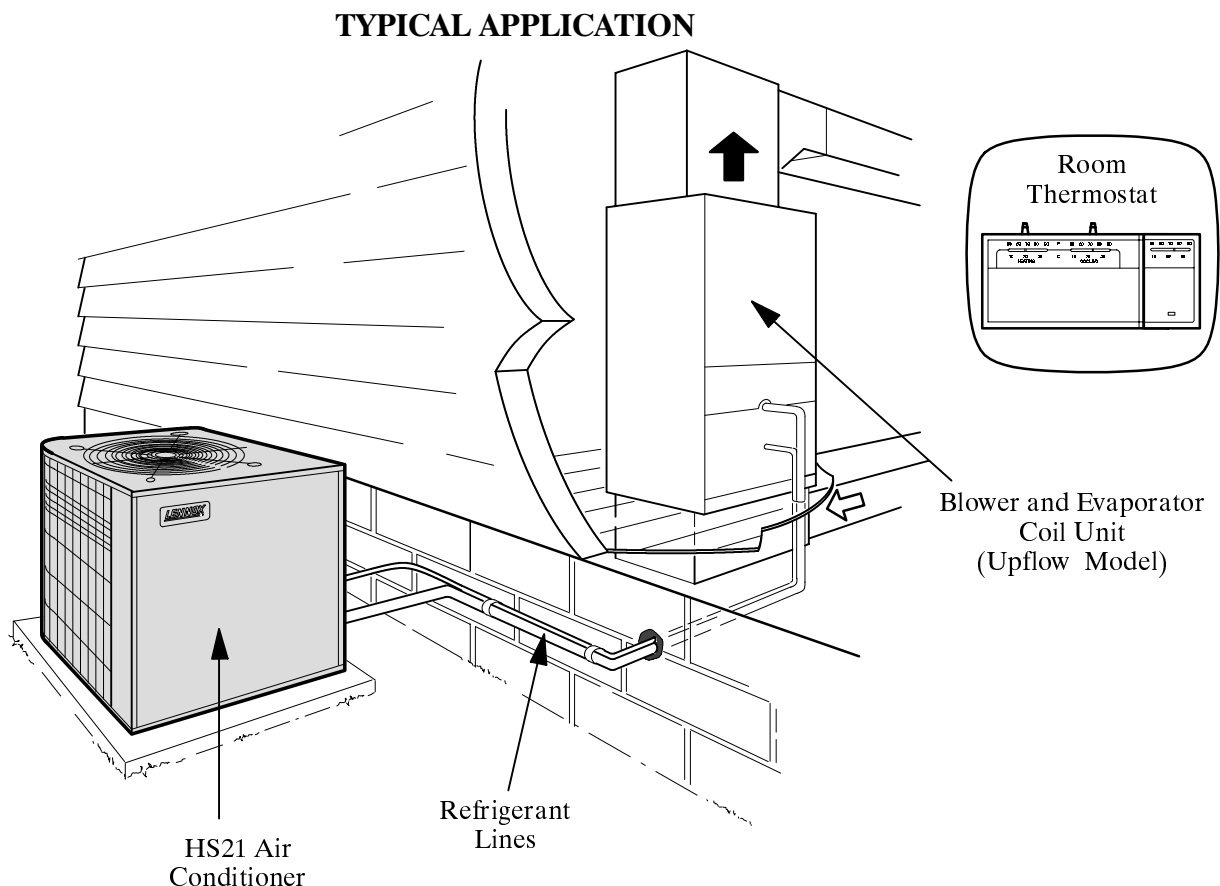

HOW TO SET THE THERMOSTAT

Your thermostat may vary from this example; however, the operation is similar.

TEMPERATURE SETTING LEVERS

Simply set the indicator lever or dial on the thermostat to the desired temperature for heating and cooling modes.

FAN SWITCH

In **AUTO** or **INT** setting, the blower runs only when the thermostat calls for either heating or cooling. The **ON** or **CONT** setting runs the blower for constant air circulation and filtering, regardless of whether the equipment is heating or cooling. In high humidity areas, the continuous fan operation tends to increase indoor humidity levels, ask your dealer which setting is best for your area.

SYSTEM SWITCH

Set the system switch for either heating, cooling or auto (if available). Auto--changeover is a setting that allows the system to heat or cool depending on the need without manually switching from one to another. This setting is useful during seasonal changes when heating may be needed in the morning and cooling in the afternoon.

TEMPERATURE INDICATOR

The temperature indicator needle shows the actual room temperature.

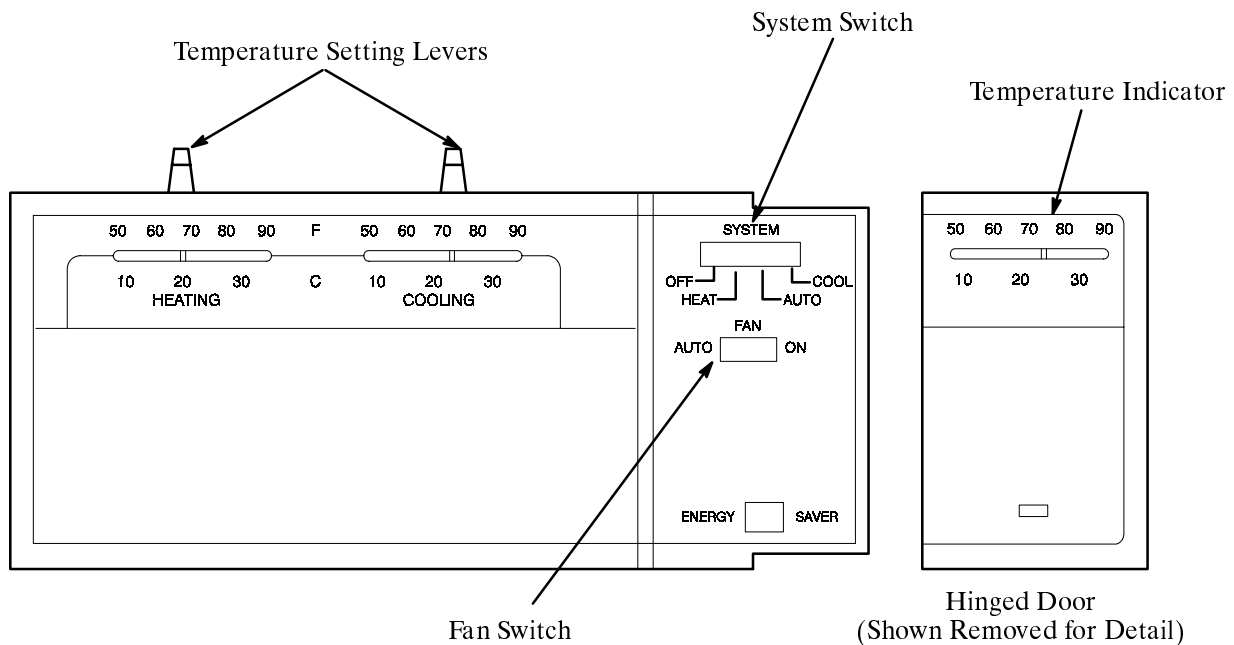

PROGRAMMABLE THERMOSTATS

Many systems are installed with a programmable thermostat. These thermostats provide the same **SYSTEM** and **FAN** control as standard thermostats, but also provide the feature of setting certain temperatures for different times of the day or days of the week. Most provide for the selection of both heating and cooling set points (the temperature at which you want that mode to come on). Refer to the separate instructions provided with your programmable thermostat for operation and adjustments.

KEEPING YOUR SYSTEM IN TOP FORM

⚠ WARNING



Electric shock hazard. Can cause injury or death. Before attempting to perform any maintenance, turn the electrical power to unit **OFF** at disconnect switch(es). Unit may have multiple power supplies.

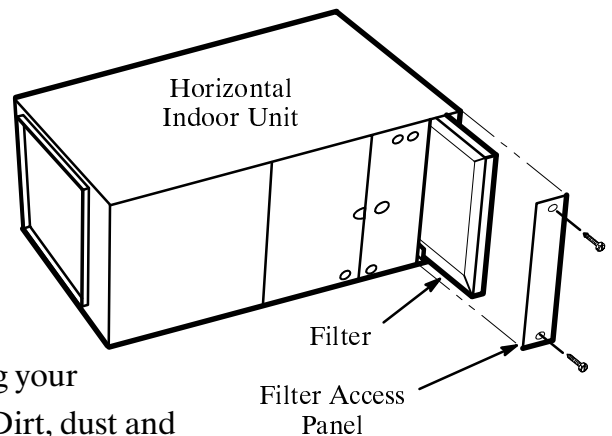

Indoor Unit and Filters

Having a clean filter is the most important step in keeping your new air conditioning system working to its full potential. Dirt, dust and pet hair clog the filter as air cycles through the system. Dirty filters make the equipment work harder which causes the unit to use more energy than normal. A system with dirty filters will not put out cool air! Cleaning or replacing the filter is much less expensive than higher energy bills or damaged equipment.

Have the dealer show you where your unit's filter is located. The filter may be found either in the indoor unit (furnace) or in the wall at the return air grille. If the filter is in the indoor unit, it may be behind an access panel as shown. Always replace the filter with the same type of filter. If you don't know what filter you need, call your Lennox dealer with the model number of the unit. The dealer will be able to tell you what type and size filter you need. Make sure that all the power is **OFF** to the unit before attempting to change filter.

Some filters are re-usable and can be cleaned with a mild soap and water. These filters should be completely dried before being returned to the unit or grille. When replacing, look for the airflow direction arrow marked on the filter. Disposable filters cannot be cleaned but should be replaced every month. During times of heavy usage, it is beneficial to vacuum the filter in between changes or cleanings. Your system may include an electronic air cleaner which rids your home of even the smallest particles of dirt, dust and pollen. Ask your Lennox dealer to instruct you on its maintenance.

HS21 Air Conditioner

It is important to keep debris and shrubs away from the air conditioner. The air conditioner pulls air from the sides, over its coils and up through the center where the fan is located. If leaves, trash or shrubs are crowding the unit, airflow is restricted. This causes the unit to work harder and use more energy. Check unit periodically for debris such as lint from dryer exhausts, leaves, plastic grocery bags, etc. The air conditioner can be cleaned by first, disconnecting all power to the unit, then rinsing off with water from a garden hose.

IDENTIFYING THE MODEL NUMBER

The individual components of your heating and cooling system each have a specific name or model number. It can be found on the unit rating or unit name plate located on the side of the unit. Every part of the number has some function. It identifies the series, capacity or size, voltage, and the version within the series. If you experience a problem with your unit, you should be prepared to give the unit model number when calling for service. This bit of information aids the service technician in the analysis of the problem. Each unit also has a specific serial number. This number is not usually needed by the technician during an initial call for service.

Locating Unit Model Number

Locate the unit rating plate on the side of the unit. It should look similar to the one shown. Notice the number that starts with **HS**. This is the model number for the air conditioner. The indoor unit's model number will start with a **G** if it is a gas furnace, a **B** if a blower unit, an **O** if an oil furnace, or a **CB** if a blower coil unit.

The number following the letter(s) describes the line or series of the unit. In this case, the HS21 series air conditioner. The set of numbers following the series describes the capacity or size of the unit and the phase or type of electricity used. The number listed after a dash (-) signifies a specific version of the series and the type of voltage used to operate the unit. Sometimes other letters will be added between the capacity and dash number. These describe certain parts used in the equipment such as specific blowers or refrigerant metering devices.

When you have found the model number, write it down in the place provided on the warranty for future reference.

LENNOX Industries Inc.	
MODEL	HS21-411-1P
SERIAL	5292K01506

Air Conditioner
Unit Rating
Plate

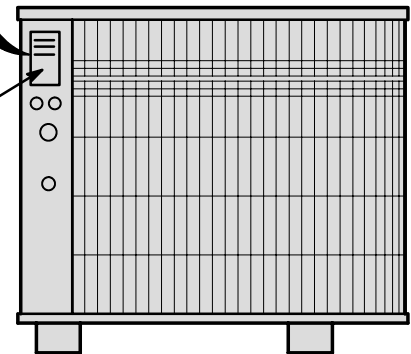

BEFORE CALLING FOR SERVICE...

- 1 Check to see that electrical disconnect switches are ON.
- 2 Make sure the room thermostat temperature selector is properly set.
- 3 The room thermostat system switch should be in the ON position.
- 4 Replace any blown fuses, or reset circuit breakers.
- 5 Make sure unit access panels are in place.
- 6 Air filter should be clean.
- 7 Write down the unit model number before calling.