

These instructions are to be stored next to the boiler for reference purposes.

FOR YOUR SAFETY: This product must be installed and serviced by a professional service technician, qualified in hydronic boiler installation and maintenance. Improper installation and/or operation could create carbon monoxide gas in flue gases which could cause serious injury, property damage, or death. Improper installation and/or operation will void the warranty.

⚠ WARNING

If the information in this manual is not followed exactly, a fire or explosion may result causing property damage, personal injury or loss of life.

Do not store or use gasoline or other flammable vapors and liquids in the vicinity of this or any other appliance.

WHAT TO DO IF YOU SMELL GAS

- **Do not try to light any appliance.**
- **Do not touch any electrical switch; do not use any phone in your building.**
- **Immediately call your gas supplier from a nearby phone. Follow the gas supplier's instructions.**
- **If you cannot reach your gas supplier, call the fire department.**

Installation and service must be performed by a qualified installer, service agency, or gas supplier.

TABLE OF CONTENTS

SECTION 1.

General Information

1A.	Introduction	3
1B.	Warranty	3
1C.	Heater Identification	3
1D.	Flow Requirements	3
1E.	Boiler Placement	4
1F.	Gas Supply and Piping	4
1G.	Combustion Air Supply	5
1H.	Venting	6
1H-1.	Vertical Venting - Category I.....	7
1H-2.	Horizontal Venting - Category III	8
1H-3.	Common Venting System	9
1I.	Water Piping of Boiler System	10
1I-1.	By-Pass Piping	10
1J.	Chilled Water Systems	10
1K.	Electrical Wiring	12
1L.	Filling the System	12

SECTION 2.

Operating Procedures

2A.	System Start-up	15
2B.	Sequence of Operation	17

SECTION 3.

3A.	Maintenance	17
3B.	Electrical Troubleshooting	18

SECTION 1. General Information

⚠ WARNING

The JVi induced draft hydronic boiler must be installed in accordance with the procedures detailed in this manual, or the Laars warranty will be voided. The installation must conform to the requirements of the local jurisdiction having authority, and, in the United States, to the latest edition of the National Fuel Gas Code, ANSI Z223.1. In Canada, the installation must conform with the latest edition of CAN/CGA B149.1 OR .2 installation codes for gas burning appliances, and/or local codes. Any modifications to the boiler, its gas controls, gas orifices, wiring or draft inducer assembly may void the warranty. If field conditions require modifications, consult the factory representative before initiating such modifications.

1A. Introduction

This manual provides information necessary for the installation, operation, and maintenance of the Laars Model JVi induced draft, low pressure, copper tube hydronic boilers. These boilers are available in two configurations; the JVH has a hot surface pilot ignition system and the JVP has an electronic intermittent ignition device (I.I.D.). Look for the model designation on the rating plate, which can be found on top of the boiler.

All application and installation procedures should be reviewed completely before proceeding with the installation. Consult the Laars factory, or local factory representative, with any problems or questions regarding this equipment. Experience has shown that most operating problems are caused by improper installation.

1B. Warranty

The Laars Model JVi induced draft boilers are covered by a limited warranty. A copy of the warranty

is printed on the back cover of this manual. The owner should fill out the warranty registration card and return it to Laars.

All warranty claims must be made to an authorized Laars representative or directly to the factory. Claims must include the boiler serial number and model (this information can be found on the rating plate), installation date and name of the installer. Shipping costs are not included in the warranty coverage. Some accessory items are shipped in separate packages. Verify receipt of all packages listed on the packing slip. Inspect each item for damage immediately upon delivery, and advise the carrier of any shortages or damage. Any such claims should be filed with the carrier. The carrier, not the shipper, is responsible for shortages and damage to the shipment whether visible or concealed.

1C. Heater Identification

Consult the rating plate on the boiler. The following example simplifies the heater identification:

1	2	3	4	5	6
JV	H	125	N	C	S

Table 1. Heater Identification.

1. Basic boiler series model
2. Ignition system: (H) Hot surface pilot ignition (P) Spark ignition
3. Input rate X 1000 BTU/Hr
4. Gas Type: (N) Natural (P) Propane
5. Firing rate: (C) On/off, induced draft
6. Options: (S) Standard, (P) with Pump, (A) Extra Aquastat

1D. Flow Requirements

All high recovery, low volume water boilers must have adequate flow for proper operation. Pump selection is critical to this goal, and pumps should be selected to provide for correct system design water temperature rise. Table 2 details temperature rise and water flow for the Mini-Therm boilers.

Size	15°F 8°C				20°F 11°C				25°F 14°C			
	Flow Rate		Headloss		Flow Rate		Headloss		Flow Rate		Headloss	
	gpm	l/s	ft	m	gpm	l/s	ft	m	gpm	l/s	ft	m
50	5.3	0.3	0.3	0.1	4.0	0.3	0.2	0.1	3.2	0.2	0.1	0.0
75	8.0	0.5	0.6	0.2	6.0	0.4	0.3	0.1	4.8	0.3	0.2	0.1
100	10.7	0.7	1.3	0.4	8.0	0.5	0.7	0.2	6.4	0.4	0.5	0.2
125	13.3	0.8	2.2	0.7	10.0	0.6	1.3	0.4	8.0	0.5	0.8	0.2
160	17.0	1.1	2.5	0.8	12.8	0.8	1.8	0.5	10.2	0.6	1.2	0.4
225	24.0	1.5	5.0	1.5	18.0	1.1	3.1	0.9	14.4	0.9	1.9	0.6

gpm = Water Flow in gallons per minute. l/s = Water flow in liters per second.
ft = Pressure drop (headloss) through the boiler in feet of water. m = Pressure drop (headloss) through the boiler in meters of water.
Note: Shaded area is the recommended flow and temperature rise.

Table 2. Temperature Rise (degrees °F, degrees °C).

Damage from improper flow is not warranted.

Failure to insure proper water flow through the heat exchanger of the boiler will void the Laars warranty. Flow can be verified by measuring the difference in water temperatures between the boiler inlet (system return) and outlet (system supply). For example: For a JV-100 installation, the inlet water temperature is 160°F (71°C), and the outlet temperature is 180°F (82°C). That means there is a 20°F (11°C) temperature rise through the boiler. According to Table 2, that would indicate a flow rate of 8 gpm (0.5 l/s). Temperature rise must be measured with the longest (highest head) zone calling for heat alone.

Other factors to be considered before selecting a pump are pipe size, the number and type of fittings throughout the system, smoothness of the interior surface of the pipe, the quantity of water flowing through the pipe, whether a glycol solution (for freeze protection) is being used, and the total length of piping in the system. Table 3 can help in proper pump selection.

Size	1/2" Pipe		3/4" Pipe			1" Pipe			1-1/4" Pipe		
	Pump H.P.		Pump H.P.			Pump H.P.			Pump H.P.		
	1/25	1/12	1/25	1/12	1/6	1/25	1/12	1/6	1/25	1/12	1/6
50	50	99	390	680	*	*	*	*	*	*	*
75	*	35	160	300	460	640	*	*	*	*	*
100	*	*	77	150	260	330	620	*	*	*	*
125	*	*	27	80	140	170	360	600	*	*	*
160	*	*	*	25	72	57	160	330	190	480	*
225	*	*	*	*	*	*	*	110	*	69	330

*A circular and/or primary/secondary piping are required. Consult factory.
 1. Chart is based on 30°F (17°C) maximum temperature rise.
 2. Calculations are based on Type L copper tubing with one zone valve and eight elbows.
 3. Typical circulating pumps: 1/25 HP=Taco 007, B&G LR-20 or SLC-25, Grundfos UP15-42F, or equivalent. 1/2 HP=B&G LR-12, Grundfos U26-42F, or equivalent. 1/6 HP=B&G series HV, Grundfo UP43-75, or equivalent.

Table 3. Maximum Suggested Circuit Length in Feet.

1E. Boiler Placement

WARNING
 This boiler is intended for indoor installation only.

- The boiler must be placed to provide clearances on all sides for maintenance and inspection. There must also be minimum distances maintained from combustible surfaces. Avoid locations which can be damaged by water or moisture.
- A minimum of 15" (381mm) access must be available in front of the boiler for burner tray removal. Consult local codes for clearances to hot water pipes and accessories.

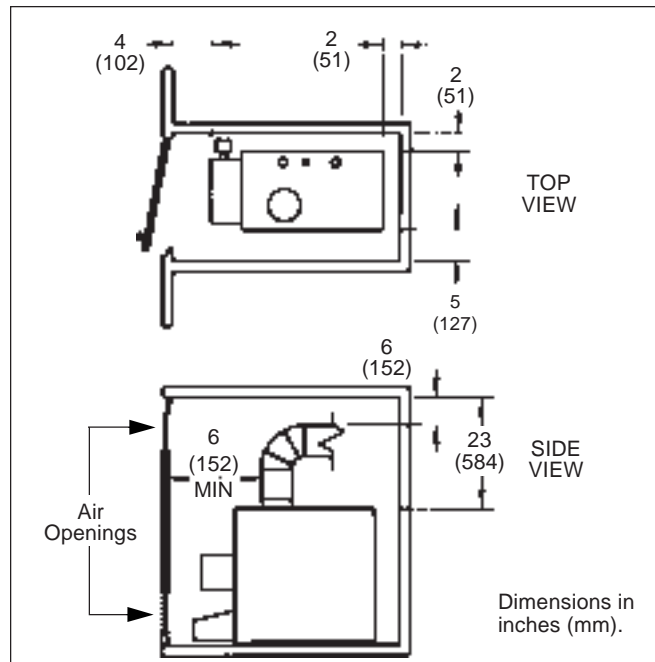

Figure 1. Closet Installation.

- If the boiler is to be installed in a garage, all burners and burner ignition devices must have a minimum 18" (457mm) clearance above the floor.
- The Model JVi-50 through JVi-225 boilers can be installed in a closet as long as the minimum clearances shown in Table 4 are observed. Special attention should be paid to clearances between the front of the boiler and the closet door when it is closed (see Figure 1).

Caution
 Do not install this boiler in a location subject to negative pressure, or improper operation will occur.

Boiler	Left Side	Right Side	Rear	Front	Flue*	Top
Sizes: 50 to 225	2" / 51mm	5" / 127mm	2" / 51mm	4" / 102mm	6" / 152mm	23" / 584mm

*1" (25mm) clearance using Type B double wall vent pipe.

Table 4. Minimum Boiler Clearances From Combustible Surfaces.

5. All boilers are designed and certified for installation on a combustible floor. Ensure that the boiler is level from all sides. NEVER store objects on or around the boiler. Boilers must NEVER be installed on carpeting.

1F. Gas Supply and Piping

Review the following instructions before proceeding with the installation.

- Verify that the boiler is fitted for the proper type of gas by checking the rating plate. Laars boilers

are normally equipped to operate below a 2000' (610m) altitude. Boilers equipped to operate at higher altitudes have appropriate stickers or tags attached next to the rating plate.

2. Use the figures in Table 5 to provide adequate gas piping from the gas meter to the boiler.
3. A trap (drip leg) must be provided ahead of the gas controls (see Figure 3). A manual gas shutoff valve approximately 5' (1.5m) above the floor must also be provided for service, convenience and safety. Check the local codes.
4. Disconnect the boiler from the gas supply pipe before pressure testing the pipe for gas leaks.
5. Provide gas supply pressure to the boiler per Table 6. The regulator is pre-set at the factory, and normally requires no further adjustment.

NOTE : The boiler and all other gas appliances sharing the boiler gas supply line must be firing at maximum capacity to properly measure the inlet supply pressure. Low gas pressure could be an indication of an undersized gas meter and/or obstructed gas supply line.

6. Before operating the boiler, the complete gas supply system and all connections must be tested for leaks using a soap solution.

1G. Combustion Air Supply

The boiler location must provide sufficient air supply for proper combustion, and ventilation of the surrounding area as outlined in the latest edition of

Distance From Gas Meter in Feet (m)	Boiler Size					
	50	75	100	125	160	225
	Inches					
0-50' (0-15)	1/2	3/4	3/4	3/4	1	1
50-100' (15-30)	3/4	3/4	3/4	1	1	1-1/4
100-200' (30-60)	3/4	1	1	1	1-1/4	1-1/4

NOTE: These figures are for Natural Gas (.65 Sp. Gr.), and are based on 1/2" water column pressure drop. Check supply pressure with a manometer, and local code requirements for variations. For LPG, reduce pipe diameter one size, but maintain a 1/2" minimum diameter. A 'normal' number of Tees and elbows have been taken into allowance.

Table 5. Gas Piping Size.

Gas Pressure	Natural Gas		Propane (LP)	
	in. W.C.	kPa	in. W.C.	kPa
Minimum Supply Pressure	5.5	1.4	10	2.5
Maximum Supply Pressure	9	2.2	14	3.4
Manifold Gas Pressure	4	1	9	2.2

Table 6. Gas Pressure Measurement.

Size	A		B		C		Water Connection	Gas Connection
	in.	mm	in.	mm	in.	mm		
50	13-3/8	340	3-1/8	79	2-7/8	73	1-1/4	1/2
75	13-3/8	340	2-1/4	57	2	51	1-1/4	1/2
100	16-7/8	429	5-3/4	146	2-7/8	73	1-1/4	1/2
125	16-7/8	429	5-1/2	140	2	51	1-1/4	1/2
160	20-3/8	518	7-1/4	184	2	51	1-1/4	1/2
225	25-5/8	651	10	254	2	51	1-1/4	3/4

Table 7. JVi Dimensions.

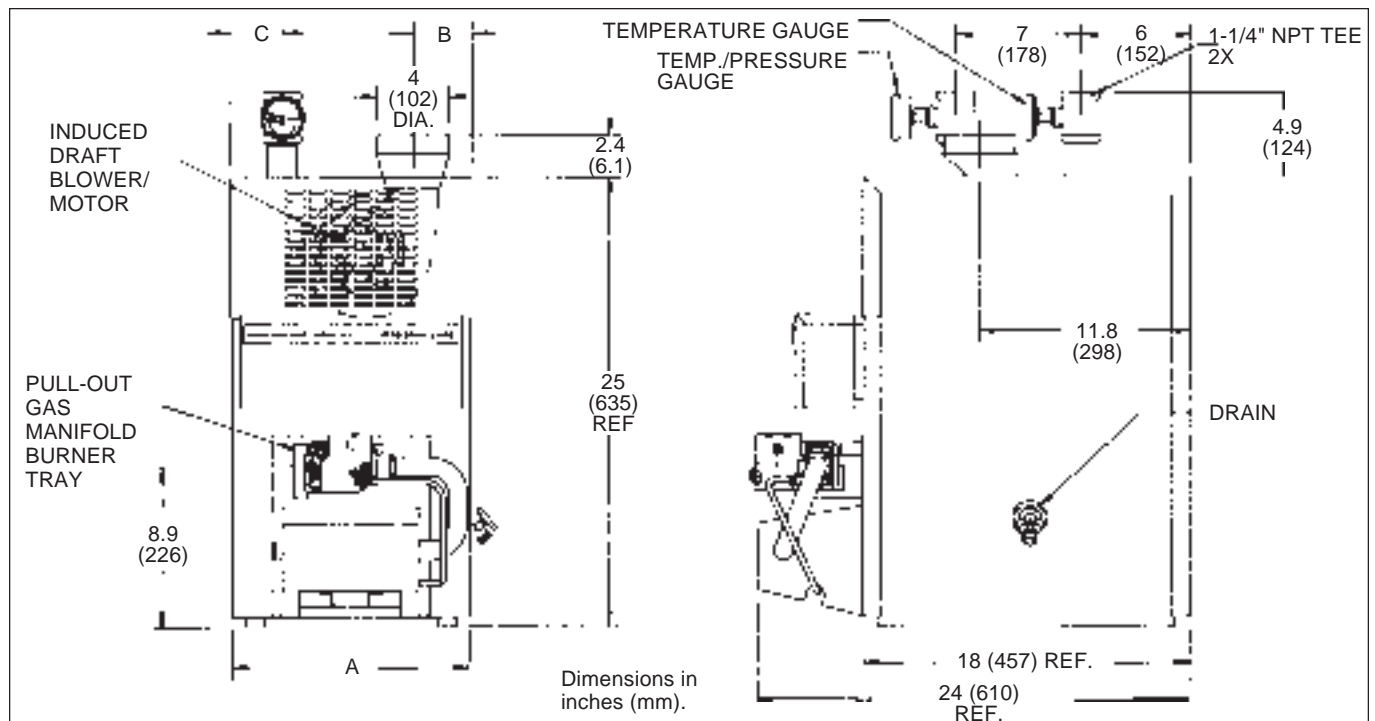

Figure 2. Dimension Information.

U.S. ANSI standard Z223.1 or in Canada, CAN/CGA-B149.1 or .2, and any local codes that may be applicable.

In general, these requirements specify that the boiler rooms which represent confined spaces should be provided with two permanent air supply openings; one within 12 inches (305mm) of the ceiling, the other within 12 inches (305mm) of the floor.

Outside Air Supply: When combustion air is supplied directly through an outside wall, each opening should have a minimum free area of one square inch per 4,000 BTU/h (6 sq. cm per 1.2 kW) input of the total input rating of all appliances in the enclosed area.

Inside Air Supply: When combustion is supplied from inside the building, each opening should have a minimum free area of one square inch per 1,000 BTU/h (6 sq. cm per 0.3 kW) input of the total input rating of all appliances in the enclosed area. These openings should never be less than 100 square inches (645 sq. cm).

NOTE: In Canada, follow Canadian Standard, CAN/CGA-B149 or local codes.

Boiler Size	Outside Air Area		Inside Air Area	
	sq. in	sq. cm	sq. in.	sq. cm
50	15	97	100	645
75	20	129	100	645
100	25	161	100	645
125	32	206	125	807
160	40	258	160	1032
225	60	387	225	1452

*Area indicated is for one of two openings: one at floor level and one at the ceiling, so the total net free area would be double the figures shown. For special conditions, refer to NFPA54 ANSI Z223.1. In Canada, refer to the National Standard CAN1-B149.1 or .2, which differs from this table.

NOTE: Check with louver manufacturers for Net Free Area of Louvers. Correct for screen resistance to the Net Free Area if a screen is used.

Table 8. Minimum Recommended Air Supply to Boiler Room.

Exhaust Fans or Vents: Any equipment which exhausts air from the boiler room can deplete the combustion air supply or reverse the natural draft action of venting system. This could cause flue products to accumulate in the boiler room. Additional air must be supplied to compensate for such exhaust.

The information in Table 8 is not applicable in installations where exhaust fans or blowers of any type are used. Such installations must be designed by qualified engineers.

If a blower or fan is used to supply air to the boiler room, the installer should make sure it does not create drafts which could cause nuisance shutdowns. If a blower is necessary to provide adequate combustion air to the boiler, a suitable switch or equivalent must be wired into the boiler control circuit to prevent the boiler from firing unless the blower is operating.

The boiler must be completely isolated and protected from any source of corrosive chemical fumes such as those emitted by trichloroethylene, perchloroethylene, chlorine, etc.

1H. VENTING

⚠ WARNING

This boiler must be vented in accordance with Part 7, Venting of Equipment, of the latest edition of the National Fuel Gas code, ANSI Z223.1 and all applicable local building codes. In Canada, follow CAN/CGA B149 Installation codes. Improper venting of this appliance can result in excessive levels of carbon monoxide which can result in severe personal injury or death!

The boiler vent collar must be fastened directly to an unobstructed vent pipe of the same diameter with rustproof sheet metal screws no longer than 1/2" (13mm) and located to prevent interference with the inducer damper.

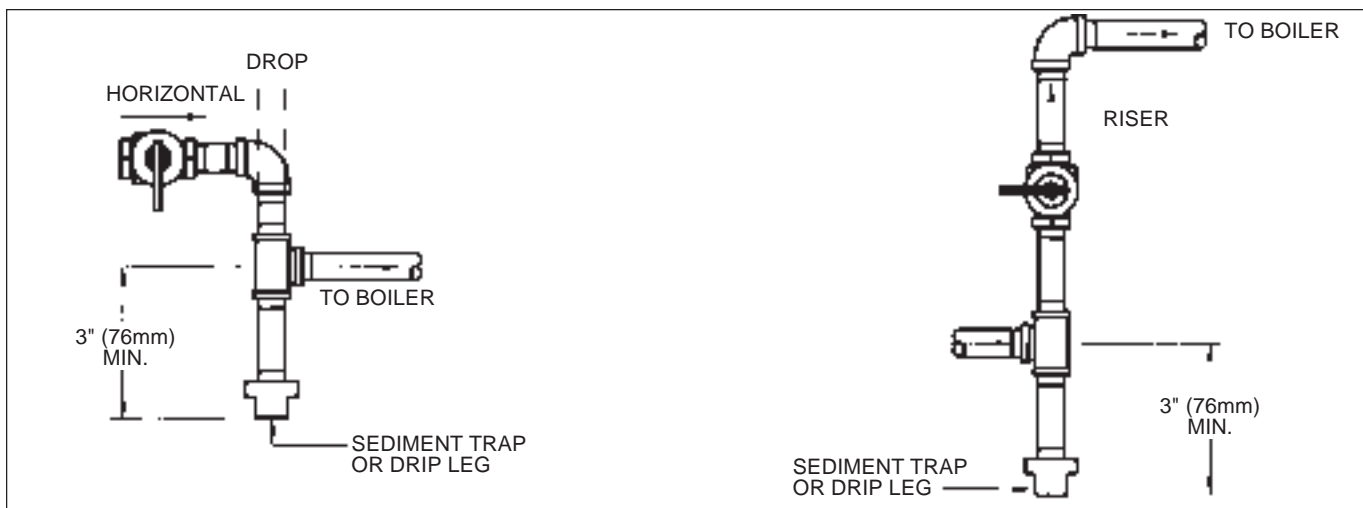

Figure 3. Gas Supply Piping.

Do not weld the vent pipe to the boiler collar. The weight of the stack must not rest on the boiler. The boiler top must be easily removable for normal boiler service and inspection.

Avoid terminating boiler vents near air conditioning or air supply fans. The fans can pick up exhaust flue products from the boiler and return them to the building, creating a possible health hazard.

Avoid oversized vent pipe or extremely long runs of the pipe, which may cause excessive cooling and condensation.

1H-1. Vertical Venting - Category I

The Mini-Therm JVi series boiler can be vented into a masonry chimney, (see Figure 4) provided several conditions are met:

1. The chimney must have an appropriate tile lining that is clean, properly constructed and properly sized.
2. The chimney passage way shall be examined to ascertain that it is clear and free of obstructions.
3. If a chimney rebuild is required, it shall conform to nationally recognized standards (see National Building Code or ANSI/NFPA 211).
4. The boiler must not be connected to a fireplace, wood stove or other solid fuel burning equipment.
5. When the boiler and a hot water heater are to be connected to the same chimney, they must have their own vent connector and enter the chimney at least 6" (152mm) apart.

(a) Vent Connections

Use type B double wall or type C single wall (26 gauge, minimum thickness), gas vent pipe from the boiler to the chimney. Installation of a riser, with a

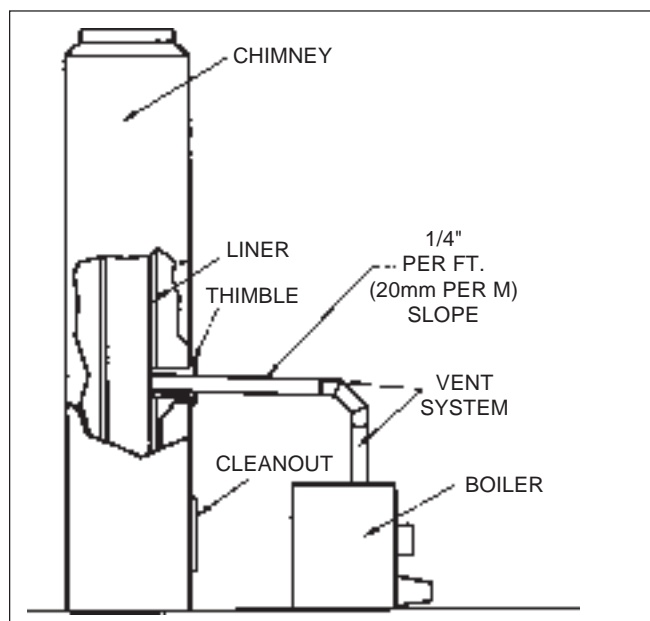

Figure 4. Chimney Venting.

minimum 12" (305mm) height above the boiler, is recommended. The vent system should be sloped up toward the chimney 1/4" per foot (20mm per meter). The vent connector must be supported for the design and weight of the material employed, to maintain clearances and prevent physical damage and separation of joints.

IMPORTANT NOTE: Always provide a minimum clearance of 6" (152mm) between Type C (single wall) vent pipe and any combustible materials.

WARNING

Single wall vent pipe must NEVER pass through interior walls or through floors or ceilings! Failure to comply with this warning could result in a fire causing property damage, personal injury, or death!

When installing the vent system all applicable national and local codes must be followed! The use of thimbles, firestops and other protective devices, when penetrating combustible or noncombustible construction, must be in accordance with all applicable national and local codes.

Vertical vents of the induced draft JVi boilers must be installed in accordance with the code requirement for Category 1, Fan Assisted Appliances. Follow the requirements as indicated in the latest edition of ANSI Z223.1/NFPA 54, sizing of Category I Venting System and Appendix G, or in Canada, follow the instruction of CAN/CGA-B149 installation code.

An unused lined chimney can be used as a raceway for single wall vent pipe, (see Figure 5). Never run vent pipe through a flue that has another appliance attached to it.

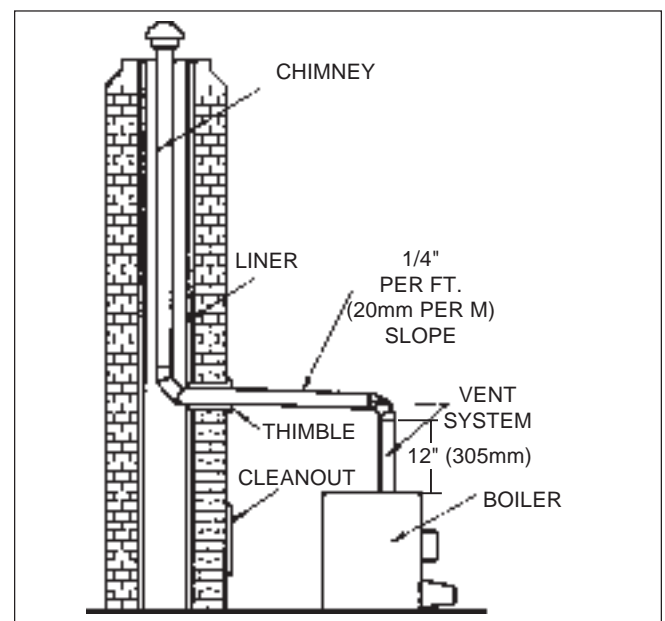

Figure 5. Vertical Venting.

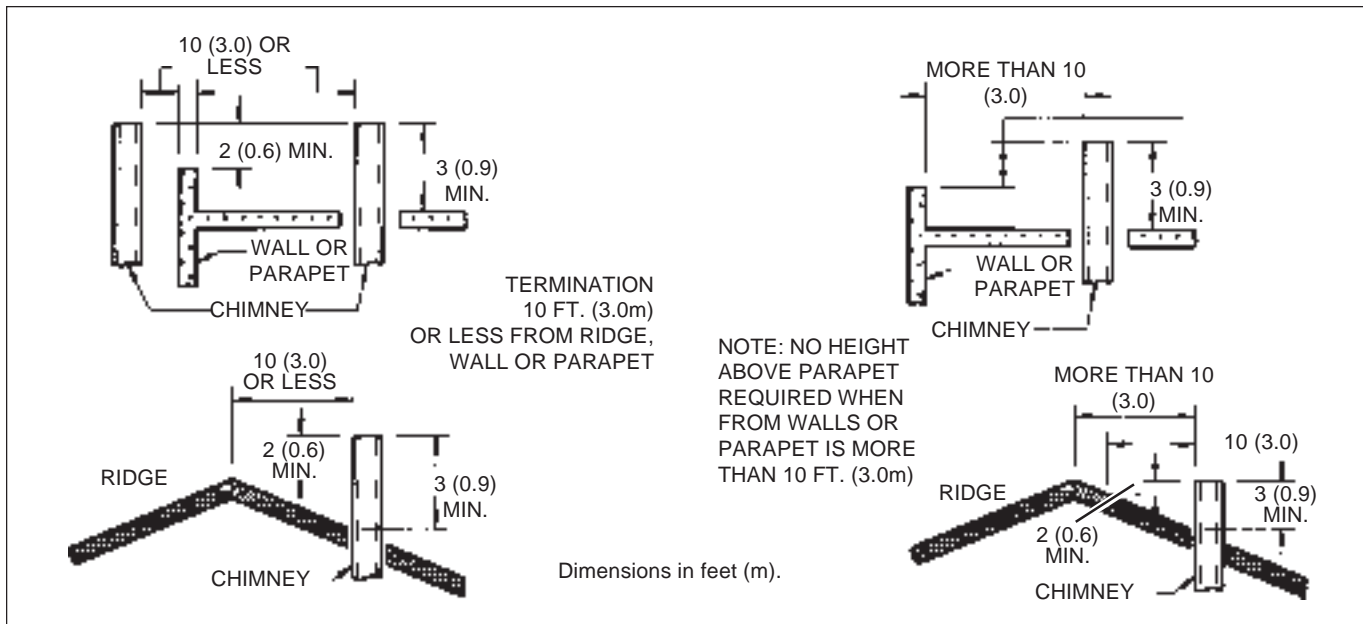

Figure 6. Vertical Vent Termination.

(b) Vent Termination

A listed vent terminal designed for the type of pipe being used must complete the vertical run where it exits the chimney. The vent pipe must extend at least 3' (.9m) above the highest point where it passed through the roof. In addition, the vent cap must be at least 2' (.6m) higher than any portion of a building within a horizontal distance of 10' (3m). Clearance to any combustible materials must be maintained as listed (see Figure 6).

For best results, horizontal vent systems should be as short and straight as possible. Material of vent connectors shall be as follows:

Materials	Vent Length
In U.S.A.: UL type 304, 316 or 294-C stainless steel, 26 gauge minimum. In Canada: Use "BH" vent type complying with ULC S-636 Standard.	Up to a maximum of 55' (17m) of equivalent pipe run (including required elbows).

1H-2. Horizontal Venting - Category III

When venting is horizontal, or cannot meet the requirements of Category I, it can develop positive pressure and must be installed in accordance with this section and the specific vent manufacturer's instructions.

The boiler vent collar must be fastened to the vent pipe of the same diameter, with rustproof metal screws no longer than 1/2" (13mm) and sealed with high temperature (500°F / 260°C) silicone sealant. For larger diameter vent pipes, use a sealed reducer fastened directly to the boiler collar and seal all joints as indicated in Figure 7. Allow the sealant to cure for 24 hours before operating the boiler.

Description	Manufacturer	Product
High Temperature RTV	Dow Corning	Trade mate
2" (51mm) wide Aluminum foil tape - adhesively backed	Venture	Product #3243
2" (51mm) wide Aluminum foil tape - adhesively backed	3M	Product #433

Table 9. Vent Sealing Materials.

The entire vent system must not exceed the size specified in Table 10.

The following criteria must be observed:

1. Attach a vertical pipe at least 12" (305mm) high to the boiler outlet before the horizontal run if run exceeds 5 feet (see Figure 7).
2. Support the vent run at 3' (.9m) intervals with overhead hangers.

(a) Vent Connections

The vent system must be gas tight. All seams and joints must be sealed with silicone sealant or adhesive tape having a minimum temperature rating of 400°F (204°C) (see Table 9 for a list of approved sealing materials). Use at least three corrosion resistant screws at each slip joint, when required.

Size	Diameter		No. of Elbows	Horizontal Run Length	
	in.	mm		ft.	m
50 - 160	4	102	4	35	10.7
225	4	102	2	10	3.0
225	6	152	4	35	10.7

For each elbow eliminated, add 5' (1.5m) of allowable vent.

Table 10. Horizontal Venting Configuration.

3. Pitch down the vent run, toward the vent terminal (hood), 1/4" per foot (20mm per meter).
4. Do not locate any joint screws at the bottom of the vent run.

(b) Vent Termination

The side wall vent terminal (hood), Laars Part Number D2004300 (4") or D2000401 (6"), must be used when the boiler is vented through a side wall. It provides a means of installing vent pipe through the building wall, and must be located in accordance with ANSI Z223.1/NFPA 54, or in Canada CAN/CGA-B149 and local applicable codes, (see Figure 8).

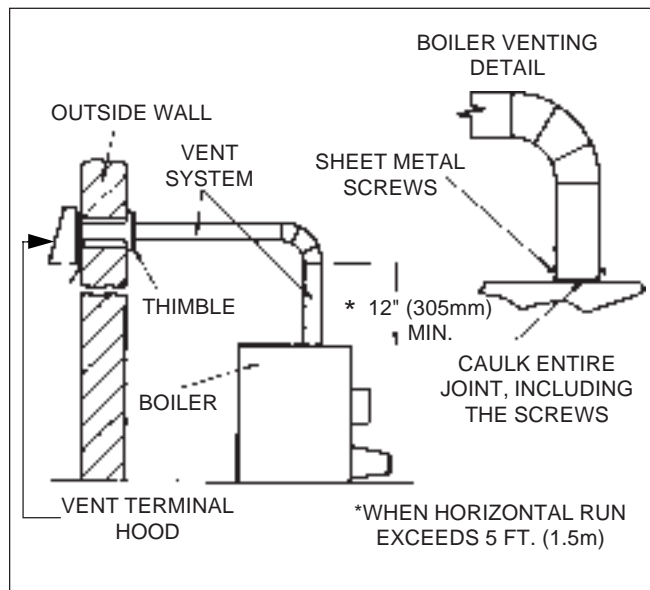

Figure 7. Horizontal Venting.

Locate the vent terminal so that it cannot be blocked by snow. Most codes requires termination of at least 12" (305mm) above grade, but the installer may determine it should be higher depending on local conditions.

1H-3. Common Venting System

When an existing boiler is removed from a common venting system, the common venting system is likely to be too large for proper venting of the appliances remaining connected to it.

At the time of removal of an existing boiler, the following steps shall be followed with each appliance remaining connected to the common venting system placed in operation, while the other appliances remaining connected to the common venting system are not in operation.

1. Seal any unused openings in the common venting system.
2. Visually inspect the venting system for proper size and horizontal pitch and determine there is no blockage or restriction, leakage, corrosion or other deficiencies which could cause an unsafe condition.
3. Insofar as it is practical, close all building doors and windows and all doors between the space in which the appliances remaining connected to the common venting system are located and other spaces of the building. Turn on clothes dryers and any gas burning appliance not connected to the common venting system. Turn bathroom exhausts, so they will operate at maximum

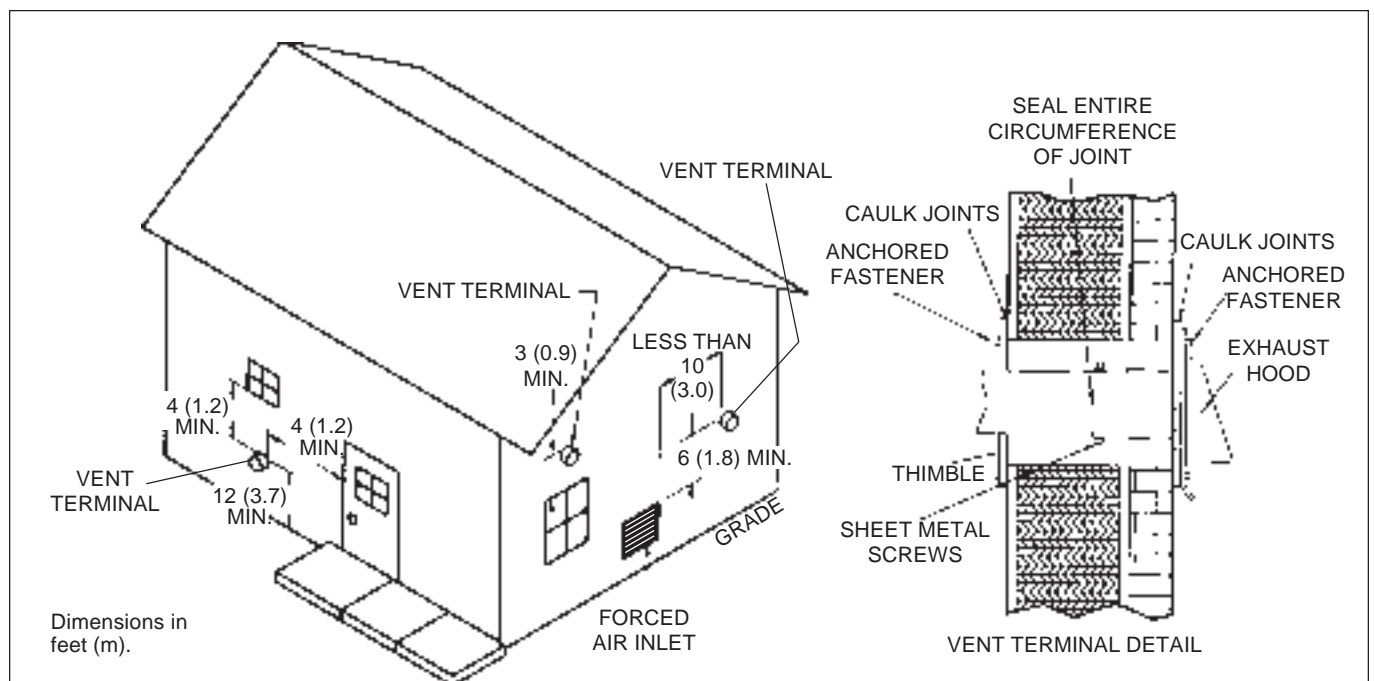

Figure 8. Horizontal Vent Termination.

- speed. Do not operate a summer exhaust fan. Close fireplace dampers.
4. Place in operation the appliance being inspected. Follow the lighting instructions. Adjust thermostat so appliance will operate continuously.
 5. Test for spillage at the burner opening after five minutes of main burner operation.
 6. After it has been determined that each appliance remaining connected to the common venting system properly vents when tested as outlined above, return doors, windows, exhaust fans, fireplace dampers and any other gas burning appliance to their previous conditions of use.
 7. Any improper operation of the common venting system should be corrected so the installation conforms with the National Fuel Gas Code, ANSI Z223.1. When re-sizing any portion of the common venting system, the common venting system should be re-sized to approach the minimum size as determined using the appropriate tables in Appendix G in the National Fuel Gas Code, ANSI Z223.1.

11. Water Piping of Boiler System

Figure 9 shows 'typical' plumbing installations. It is recommended that unions and valves are used at the boiler inlet and outlet so it can be isolated for service. Check local codes for specific plumbing requirements before beginning the installation.

An ASME pressure relief valve is supplied on all JV boilers, and is pre-set at 30 PSI (207 kPa). The relief valve outlet piping must discharge to a drain. Under no circumstances should the relief valve piping be a closed circuit.

A pressure reducing valve (automatic feed) must be used to maintain system at constant proper pressure (see Figure 9). Supply properly installed purge valves to eliminate air from each circuit.

A drain valve is supplied with the boiler, and can be found in the plastic bag shipped with each boiler. This valve is to be installed on the lower right side of the boiler (see Figure 2) and is used for draining the unit. To drain the boiler completely, open the drain valve and remove the two drain plugs located on the lower left side of the boiler.

Be sure to include air vent devices located at the highest point in the system to eliminate trapped air, and an air elimination device near the outlet side of the JV boiler. Manual vent valves are recommended.

Hot water piping should be supported by suitable hangers or floor stands, NOT by the boiler. Due to expansion and contraction of copper pipe, consideration should be given to the type of hangers used. Rigid hangers could transmit noise through the

system caused by the piping sliding in the hangers. It is recommended that padding be used when rigid hangers are installed.

A properly sized expansion tank must be included in the system. Laars offers an air-charged diaphragm-type expansion tank, with an automatic feed valve, which includes a pressure regulator set at 12 psig.

11-1. By-Pass Piping

The following information and suggestions are made on by-pass piping as it affects the temperature rise at the boiler. A boiler temperature rise must be taken on all JVi boiler installations. If the temperature rise exceeds 30°F (17°C), it is an indication that the boiler is not receiving adequate water flow. Check the pump for any obstruction, replace the pump with a larger size where necessary, or install a system by-pass (illustrated in Figure 9).

On JVi sizes 125, 160, and 225 with a multiple zone system, a by-pass is required to ensure proper flow in addition to properly sized circulator and piping system.

NOTE: On JVi sizes 160 and 225 a primary/secondary piping system is recommended. In this system, a circulator is dedicated to pumping the boiler only. This circulator should be sized for the boiler head loss and flow rate.

The two above piping configurations can also apply to JVi sizes 50, 75 and 100, but generally, these units require flow rates which are easily obtained without a by-pass.

All precautions must be taken by the installer to insure that a maximum temperature rise through the boiler does not exceed 30°F (17°C). The temperature rise on boilers installed in multi-zone systems using zone valves must be taken when the zone of the longest length and/or the zone of the highest head loss is open.

Please note that a 1" (25mm) diameter by-pass with balancing ball valve must be installed if a return water temperature of below 110°F (43°C) is expected under operating conditions (see Figure 9).

11J. Chilled Water Systems

If the boiler is installed in conjunction with refrigeration systems, it shall be installed so that the chilled medium is piped in parallel with the heating boiler with appropriate valves to prevent the chilled medium from entering the heating boiler.

When boiler piping is connected to heating coils, which are in close proximity to refrigerated air circulation, there must be flow control valves or other automatic methods to prevent gravity circulation of the boiler water during the cooling cycle.

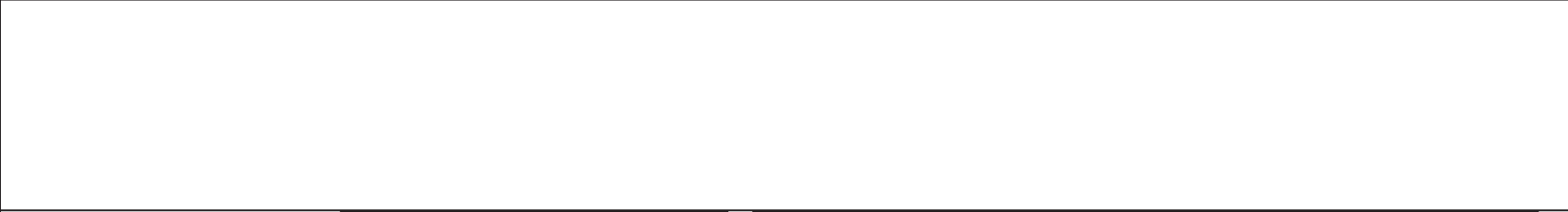
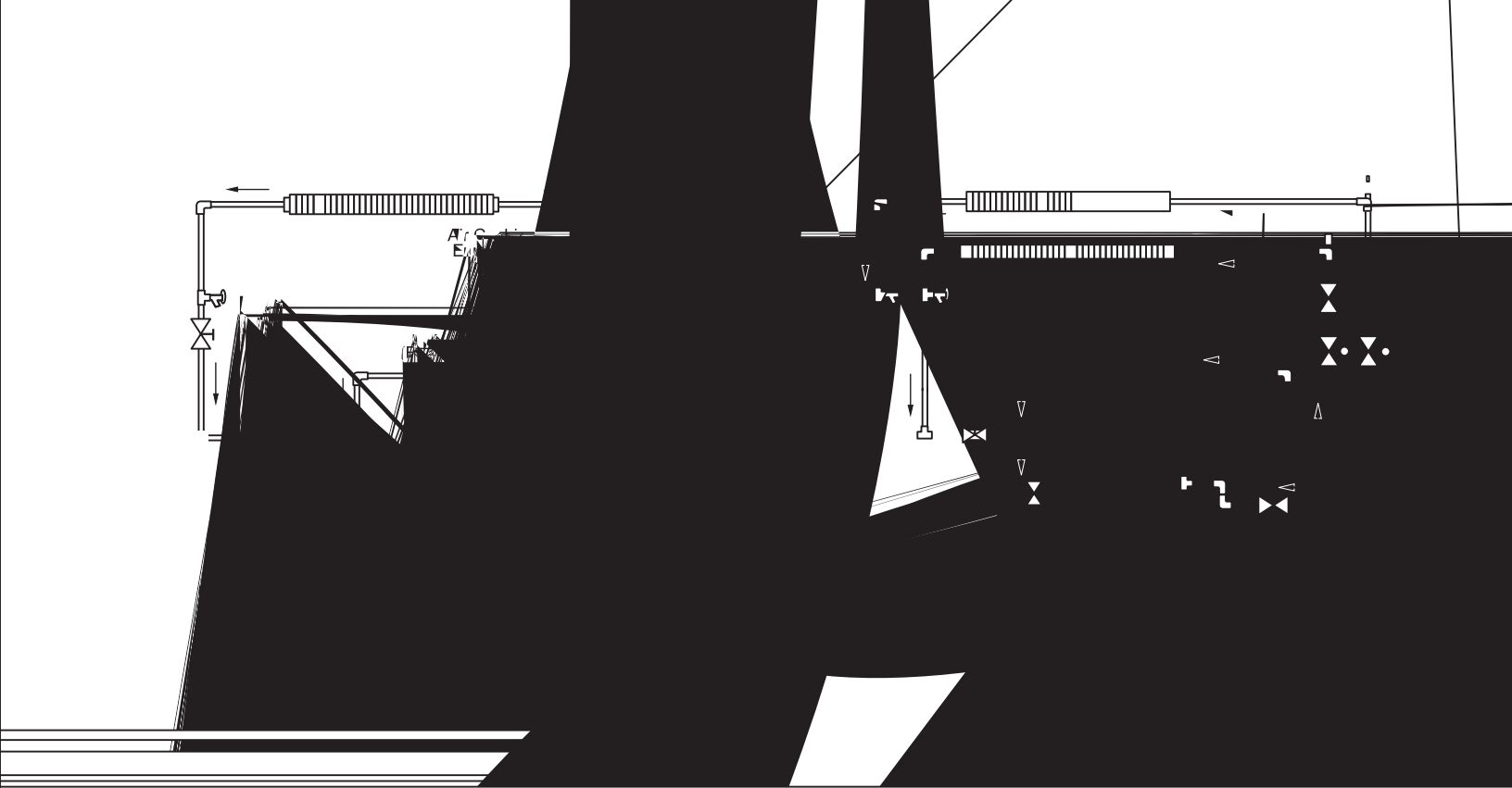

1K. Electrical Wiring

Follow these instructions to make the necessary initial electrical connections.

1. Remove the two screws attaching the front cover of the control box.
2. There are five wires coiled in the area on the right side of the control box, supplied with wire nuts: two black wires twisted together, two white wires, and a separate brown wire.
3. Follow the schematics in Figures 10 & 11. Remove the wire nut from the two black wires, and connect the hot lead from the 115V power supply, and the neutral lead to the white wires and the neutral side of the pump. The brown wire attaches to the hot side of the pump.
4. Attach the leads from the wall thermostat to the R and W terminals on the terminal strip, located on the left side of the control box.
5. Check the boiler wiring and pump for correct voltage, frequency and phase. If the pump circuit is other than 115V, be sure there is an appropriate transformer or relay installed. The pump relay is suitable for pumps of 3/4 HP or less.
6. For systems with multiple zone pumps or valves (see Figure 12).

A means of disconnecting the electrical supply must be provided within sight of the boiler. The pump and boiler must be wired as shown to insure that the pump is running whenever the boiler is firing.

WARNING

The boiler must be electrically grounded in accordance with the requirements of the authority having jurisdiction or, in the absence of such requirements, with the latest edition of the national Electrical Code, ANSI/NFPA 70, in the U.S. and with the latest edition of CSA C22.1 Canadian Electrical Code, Part 1, in Canada. Do not rely on the gas or water piping to ground the metal parts of the boiler. Plastic pipe or dielectric unions may isolate the boiler electrically. Service and maintenance personnel who work on or around the boiler may be standing on wet floors and could be electrocuted by an ungrounded boiler.

Hi-Limit Switch: Factory setting is 190°F (88°C). This setting is correct for normal operations, and should only be changed by an authorized service technician. Under no Circumstances should the setting exceed 220°F (104°C).

Flow Switch: If the system includes a flow switch, it should be wired in series with the high-limit switch. The boiler will not fire unless the pump is running and the flow switch is closed.

Field installed safety devices and operating controllers, such as valve end switches, relays, timers, and outdoor temperature reset devices, can be connected to the boiler through the wall thermostat circuit. Do not exceed a draw of 30VA on the transformer secondary.

Heat Anticipator: For single zone installations, the wall thermostat heat anticipator should be set at 1.0A. For multi-zone installations, have a qualified electrical technician make the necessary measurements and properly set the thermostats.

1L. Filling the System

It is crucial to the efficient operation of the system that all air be removed from the circuit. For this reason, an air scoop and vent should be located close to the boiler outlet, and there should be a minimum distance between cold water feed and system purge valve.

1. When the system has been completely installed, close all air vents and open the makeup water valve. Allow the circuit to fill slowly.
2. If a make-up water pump is employed, adjust the pressure to provide a minimum of 12 psi (83kPa) at the highest point in the circuit. If a pressure regulator is also installed in the line, adjust it to the same pressure.
3. Close all valves. Purge one circuit at a time as follows:
 - a. Open one circuit drain valve and let water drain out for at least 5 minutes. Be certain there are no air bubbles visible in the water stream before closing the drain valve.
 - b. Repeat this procedure for each circuit.
4. Open all valves after all circuits have been purged.
5. Run the system circulating pump for a minimum of 30 minutes with the boiler shut off.
6. Open all strainers in the system, and check for debris.
7. Recheck all air vents as described in Step 3.
8. Inspect the liquid level in the expansion tank, with the system full of water, and under normal operating pressure, to ensure proper water level in the expansion tank.
9. Start up boiler according to the procedures described in Section 2 and operate the system, including the pump, boiler, and radiation units, for one hour.
10. Recheck the water level in the expansion tank. If it exceeds 1/2 of the volume of the tank, open the tank drain and reduce the water level.
11. Shut down the entire system, and vent all radiation units and high points in the system.

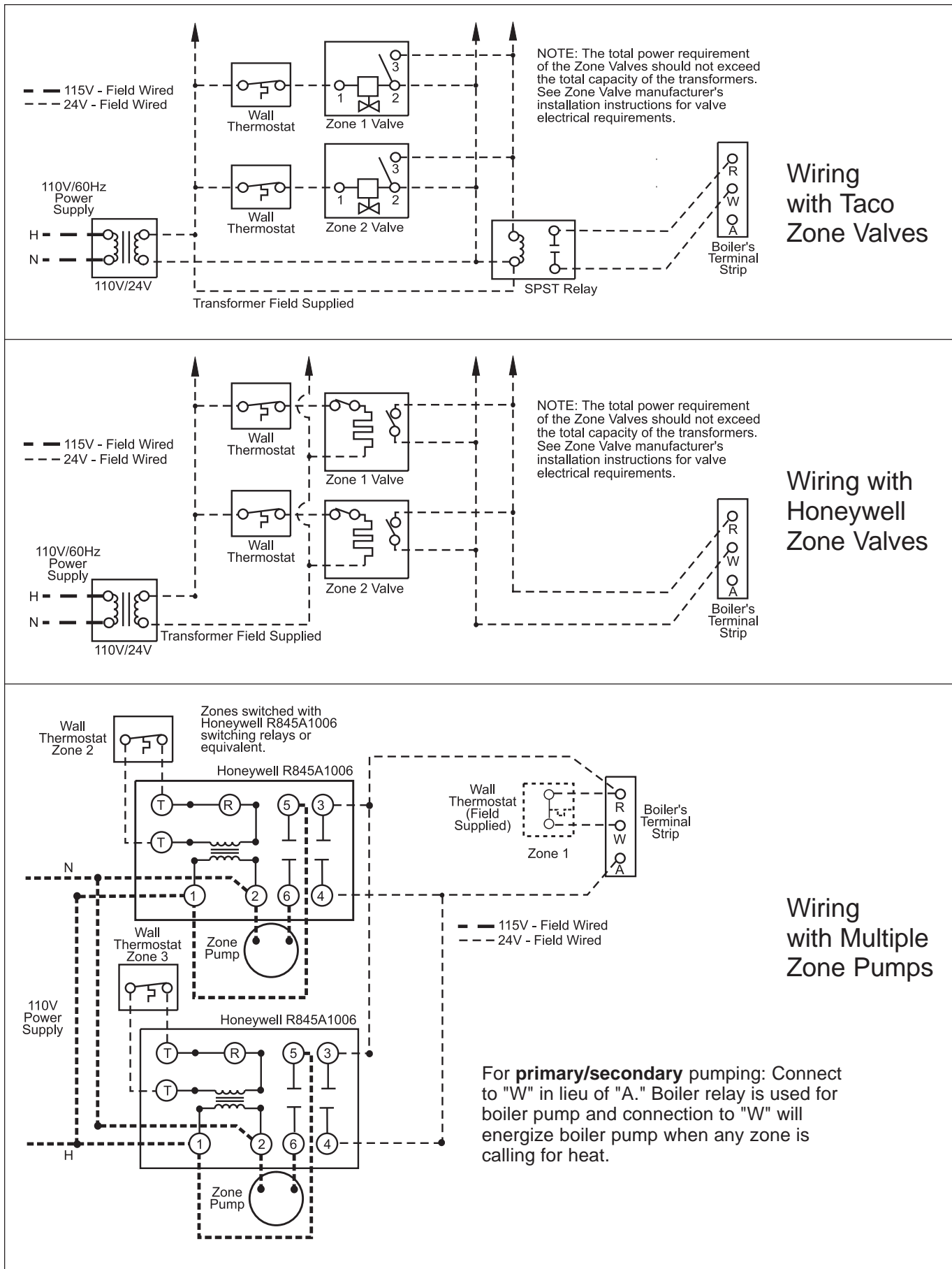

Figure 10. Multiple Zone Wiring.

12. Close the water makeup valve and check the strainer in the pressure reducing valve for sediment or debris. Reopen the water makeup valve.
13. Verify system pressure with the boiler pressure gauge before beginning regular operation.
14. Within 3 days of start-up, recheck and bleed all air vents and the expansion tank using these instructions.

SECTION 2. Operating Procedures

Before placing the boiler in operation, check and reset the safety shutoff devices. Once the boiler is connected to the gas and water piping and after all the requirements in previous pages have been met, follow these procedures:

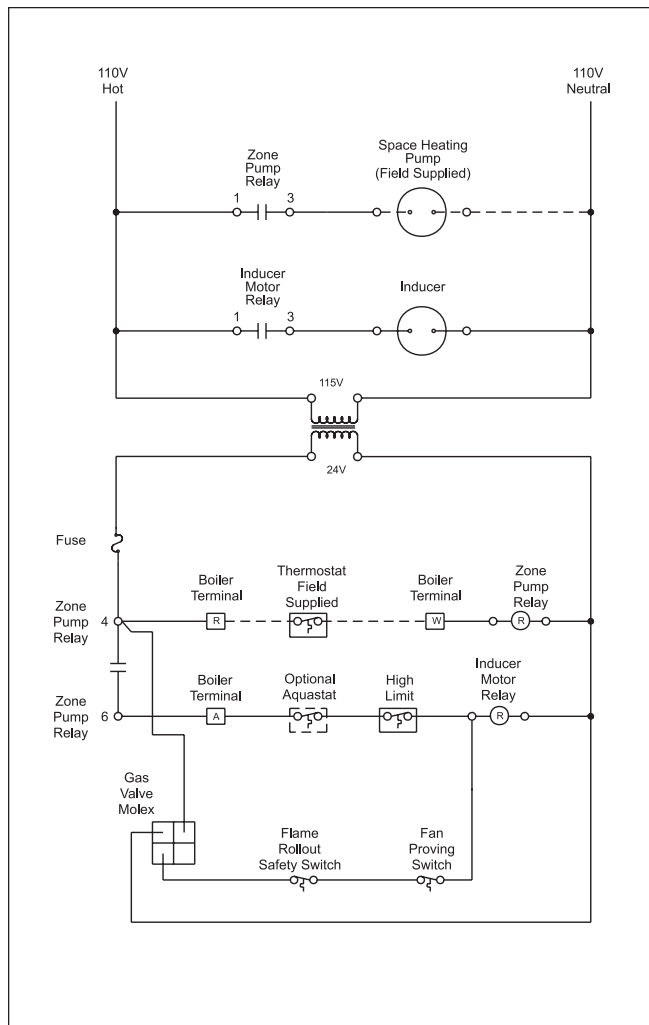

Figure 13. JVH Schematic.

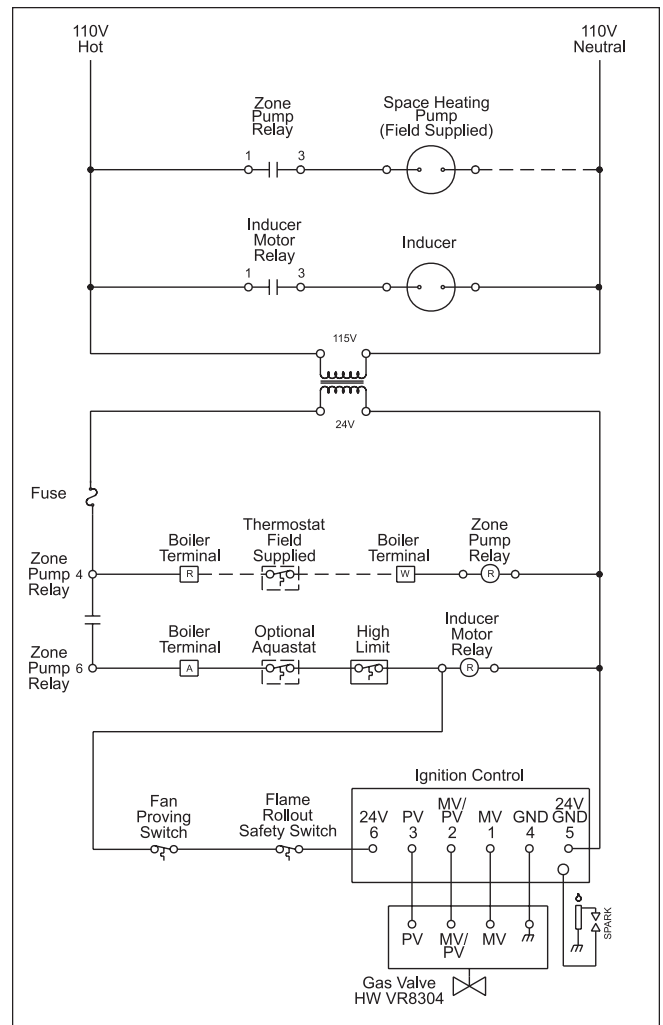

Figure 14. JVP Schematic.

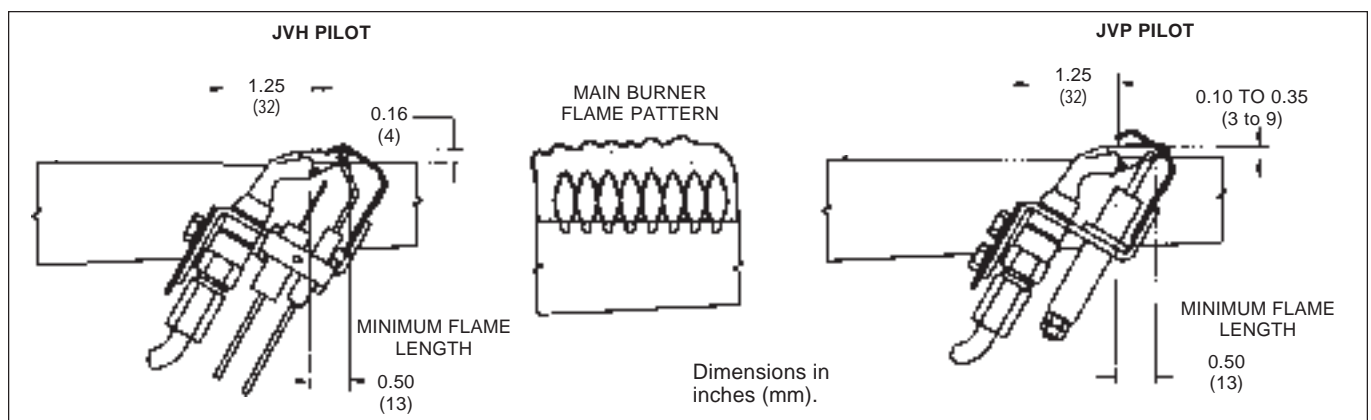

Figure 15. Main Burner/Pilot Flame Pattern.

Boiler Size	Firing Systems Natural or Propane	Valve Number	Manufacturer
50-225	Hot Surface Pilot, JVH	SV9500 & SV9600	Honeywell
	Spark Ignition, JVP	VR8304	Honeywell

Table 11. Gas Valve Identification.

2A. System Start-up

1. Verify that the pump system is operating properly:
 - a. Shut off the manual gas valve located outside the boiler.
 - b. Raise the wall thermostat high enough to call for heat.
 - c. The pump should come on immediately. If it does not, test the electrical circuits.
2. Pilot and Main Burner Lighting:
 - a. The JVH and JVP boilers do not require manual lighting. The pilot is controlled by the automatic ignition system.
 - b. Different models of the JVi boiler utilize various gas valves, (see Table 11). Although the gas valves may have different control knobs, they are all similar in operation.
 - c. Understand and follow the operating instructions, on page 14, that are applicable to the type of ignition system installed on the boiler.
3. The pilot and main burners will automatically ignite when there is a call for heat.

2B. Sequence of Operation

1. Wall thermostat will call for heat.
2. Pump relay will turn on the circulating pump.
3. If water temperature is below the limit setting, the inducer motor relay will turn on the draft inducer.
4. Pressure switch will sense the fan (inducer) operation and send 24 volts to the flame rollout switch.
5. In normal conditions, the flame rollout switch will be in a closed position.
 - a. JVH (Hot surface pilot ignition):
24 volts will be sent to the gas valve/ controller, the igniter will glow and the pilot valve will open, lighting the pilot.
 - b. JVP (Spark ignition):
24 volts will be sent to the ignition controller, the igniter will spark and the pilot valve will open, lighting the pilot.
6. After pilot is proven to be lit, the main gas valve will open, the main burners will ignite and continue until either the hi-limit or wall thermostat opens.
7. When the wall thermostat is satisfied, the burners will shut off. The relays will turn off the circulating pump and the draft inducer. When the room temperature falls below the wall thermostat setting, the cycle will repeat.

FOR YOUR SAFETY, READ BEFORE OPERATING

⚠ WARNING

If you do not follow these instructions exactly, a fire or explosion may result causing property damage, personal injury, or loss of life.

- A. This boiler is equipped with an ignition device that automatically lights the pilot. Follow operating instructions, do not try to light the pilot by hand.
 - B. BEFORE OPERATING, smell all around the boiler area for gas. Be sure to smell next to the floor because some gas is heavier than air and will settle on the floor.
- Immediately call your gas supplier from a neighbor's phone. Follow the gas supplier's instructions. If you cannot reach your gas supplier, call the fire department.
- C. Use only your hand to push in or turn the gas control knob. Never use tools. If the knob will not push in or turn by hand, don't try to repair it. Call a qualified technician. Force or attempted repair may result in a fire or explosion.
- D. Do not use this boiler if any part has been under water. Immediately call a qualified service technician to inspect the boiler and to replace any part of the control system and any gas control which has been under water.

WHAT TO DO IF YOU SMELL GAS

- Do not try to light any appliance.
- Do not touch any electric switch; do not use any phone in your building.

OPERATING INSTRUCTIONS

1. STOP! Read the safety information above, on this page.
2. Set the thermostat to the lowest setting.
3. Turn off all electric power to the boiler.
4. This boiler is equipped with an ignition device which automatically lights the pilot. Do not try to light the pilot by hand.
5. Set ignition control switch to "OFF." Turn the gas control knob (clockwise for JVP) to the full "OFF" position.
6. Wait five (5) minutes to clear out any gas. Then smell for gas, including near the floor. If you smell gas STOP! Follow "B" in the safety information above. If you don't smell gas, go to the next step.
7. Set ignition control switch to "ON." Turn the gas control knob (counterclockwise for JVP) to "ON".
8. Turn on all electric power to the boiler.
9. Set thermostat to desired setting.
10. If the boiler will not operate, follow the instructions TO TURN OFF GAS TO BOILER and call your service technician or gas supplier.

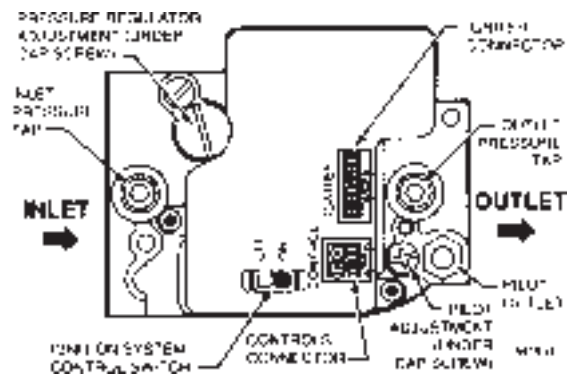

Honeywell SV9501/9601

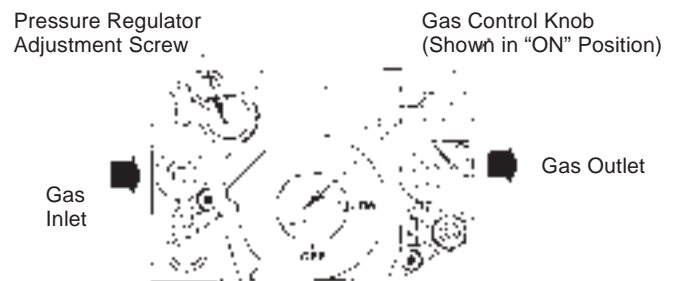

Honeywell VR8304

SECTION 3.

3A. Maintenance

1. Lubricate the water circulating pump per the instructions on the pump.
2. If a strainer is employed in a pressure reducing valve or the piping, clean it every six months.
3. At start-up, and periodically thereafter, the burner and pilot flames should be observed. If the flame has the appearance of "sooting" tips, check for debris near the orifices and call the service technician.
4. Ensure proper operation of the mechanical damper, mounted in the flue collar, by observing the damper handle. Be sure the handle swings when the draft inducer starts (depending on the boiler size, swing may be as little as 30°). Remove any obstructions and clean around the pivot rod (handle) holes.
5. Inspect the venting system for obstruction, leakage or corrosion at least once a year.
6. Keep the boiler area clear and free from combustible materials, gasoline, and other flammable vapors and liquids.
7. Be sure that all combustion air and ventilation openings are unobstructed.
8. Upon completion of the installation, inspect the external surfaces of the heat exchanger for fouling based on the following schedule:
24 hours - 7 days - 30 days - 90 days
Once every six months thereafter.
9. If the boiler is not going to be used for long periods of time in locations where freezing occurs, it should be completely drained of all water. To accomplish this, there is a drain valve on the right side of the boiler which can be opened. This will drain the right side of the boiler. There are two plugs located on the left side of the heater which must be removed to drain that side. Both sides must be drained.
10. The gas and electric controls on the boiler are engineered for long life and dependable operation, but the safety of the equipment

depends on their proper functioning. It is strongly recommended that the basic items listed below be inspected by a qualified service technician every year.

- a. Water temperature controls.
- b. Pilot safety system.
- c. Automatic gas valves.
- d. Fan proving switch.
- e. Inducer/Blower assembly.
- f. Mechanical flue damper operation.

WARNING

The Warranty does not cover damage caused by lack of required maintenance, lack of water flow, or improper operating practices.

Fouling on the external surfaces of the heat exchanger is caused by incomplete combustion, and is a sign of venting and/or combustion air problems. The heat exchanger can be inspected by using a flashlight and placing a mirror under the burners. An alternate method is to remove the venting and top panel to inspect the exchanger from above. The vent system should be inspected at the same time. If cleaning is required:

- a. Shut off all power to the boiler.
- b. Remove the venting top, flue collector, draft inducer assembly, and heat exchanger baffles.
- c. Remove the burner tray.
- d. Use a hand-operated spray bottle filled with water, and a wire brush to clean soot and loose scale from the underside of the heat exchanger. **DO NOT USE COMPRESSED AIR, HIGH PRESSURE WATER, OR A GARDEN HOSE.**
- e. Clean any fallen debris from the bottom of the unit.
- f. Check to make sure the burner ports and pilot assembly are free of debris before returning the burner tray to its original position.
- g. Reassemble the boiler in reverse order, making sure to replace the heat exchanger baffles.

3B. Electrical Troubleshooting

1. Remove the control box cover on the front of the boiler.
2. Verify that 115 volts is reaching the boiler by testing across the black wire and the white wire on the transformer.
3. Verify 24 volts transformer output by placing the meter leads on the yellow and red wires. If 24 volts is not evident, replace the transformer. Perform the following series of tests with one meter lead attached to the yellow wire on the transformer.
4. Place the second lead on the “W” connection on the terminal board. Turn the wall thermostat high enough to call for heat. If the meter fails to register 24 volts, the thermostat or its circuit may be defective.
5. Make sure the thermostat is set high enough to call for heat. Place second lead on the “A” connection on the terminal board. If voltage is evident, skip to step 6.
If no voltage, test the circuit between the red wire on the transformer and terminal 4 on the pump relay; from terminal 6 on the pump relay and the “A” connection on the terminal board; and from the orange wire terminal on the pump relay to the “W” connection on the terminal board. If no output is found, the connections or the pump relay could be defective.
6. Place the second lead on the purple wire terminal on the hi-limit switch. If no voltage across the

switch, check for defective hi-limit, open circuit due to excessive water temperature, or a low temperature setting.

7. Place the second lead on the blue wire terminal on the fan proving switch. If voltage is present, skip to step 8. If voltage isn't present, connections or the draft inducer/motor could be defective.
8. Verify the voltage across the roll-out safety switch.
9. If it is determined that there is voltage to the gas valve, the pilot is lit and the pilot sensor is properly positioned, and the thermostat is set high enough to call for heat, the gas valve or the pilot assembly may be defective.

Caution

Label all wires prior to disconnection when servicing controls. Wiring errors can cause improper and dangerous operation. Verify proper operation after servicing.

WARNING

Follow local regulations with respect to installation of carbon monoxide (CO) detectors and manufacturer's maintenance schedule of the boiler.

#	Symptom	Cause	Remedy
1.	Pump not operating	No power Pump defective Incorrectly wired	Check circuit breakers and power source. Replace. Recheck wiring diagrams.
2.	Pilot outage	Inlet gas pressure too low Inlet gas pressure too high causing an unstable blowing pilot Damaged pilot Dirty pilot Plugged or undersized pilot orifice	Consult gas utility company. Inlet gas pressure to boiler should be 5.5" (1.4 kPa) to 9.0" (2.2 kPa) water column on natural gas. 10.0" (2.5k Pa) to 14.0" (3.4 kPa) on propane gas. Pressure should be regulated within limits shown above. Replace. Blow dust or lint out of pilot. Clean or replace pilot orifice.
3.	Flame roll-out on start-up	Blocked outlet Pilot out of position (delayed ignition) Blocked heat exchanger or flue Refractory tile out of place	Check flue damper operation. Correct pilot position. Clean and correct as necessary. Correct or replace tile as necessary.
4.	Flame has lazy yellow tip	Low primary air	Correct manifold pressure according to rating plate. Correct orifice size if necessary (see parts list). Clean burner ports if dirty.
5.	Not enough heat	Inadequate gas supply Low manifold gas pressure Boiler size inadequate	Gas meter too small. Gas line from meter to boiler too small. Gas pressure on boiler manifold, with Modusnap valve wide open. Should be adjusted to 4.0" (1.0 kPa) W.C. natural gas, 9.0" (2.2 kPa) W.C. propane. Replace with boiler of higher input.
6.	Pump noisy	Air in volute Worn coupling or bearings	Bleed air from volute. Check pump alignment. Replace worn parts.
7.	Boiler pounding or knocking	Too low water flow through boiler	Check temperature rise between inlet and outlet boiler piping. 15°F (8°C) to 25°F (14°C) temperature rise is recommended. If temperature rise is over 25°F (14°C), increase pipe size or pump capacity or locate obstruction. Check for stuck closed zone valves. Check for zone pumps not operating. Check for closed valve in system.
8.	Boiler condensing	Low water temperature	Flue product moisture will condense at the start-up until the boiler water temperature reaches the normal operating conditions.
9.	Pump cavities or low water pressure at boiler gauge or bubbles in system at high temperature	Defective fill valves or pressure regulator Oversized expansion tank Expansion tank piped incorrectly	Replace. Replace. Repipe expansion tank to suction size of pump.
10.	Pressure relief valve opens	Waterlogged expansion tank	Drain 2/3 of the water from the expansion tank.
11.	Pilot is lit but main burners will not come on	Boiler off on hi-limit control Boiler incorrectly wired Boiler off on flame roll-out switch Broken wire in thermostat circuit or defective thermostat	Check for low water flow or hi-limit setting. On single or multiple zone systems with zone valves, room thermostat should be wired to R&W terminals. For multiple zone systems with ozone pumps, thermostats for extra zones should be wired to R&A terminals. Remedy as in symptom #3. Reset the manual reset switch. Check continuity through thermostat circuit with wires disconnected from R&W.
12.	Boiler short cycles	Heat anticipator in room thermostat set too low Low water flow through boiler Hi-limit switch may be set too low	Increase setting (1.0 is usually satisfactory) Increase size of pump or increase piping size. Increase setting to at least 20°F (11°C) over outlet water temperature.

Table 12. Troubleshooting Analysis.

Troubleshooting Honeywell SV9501/SV9601 Hot Surface Pilot System

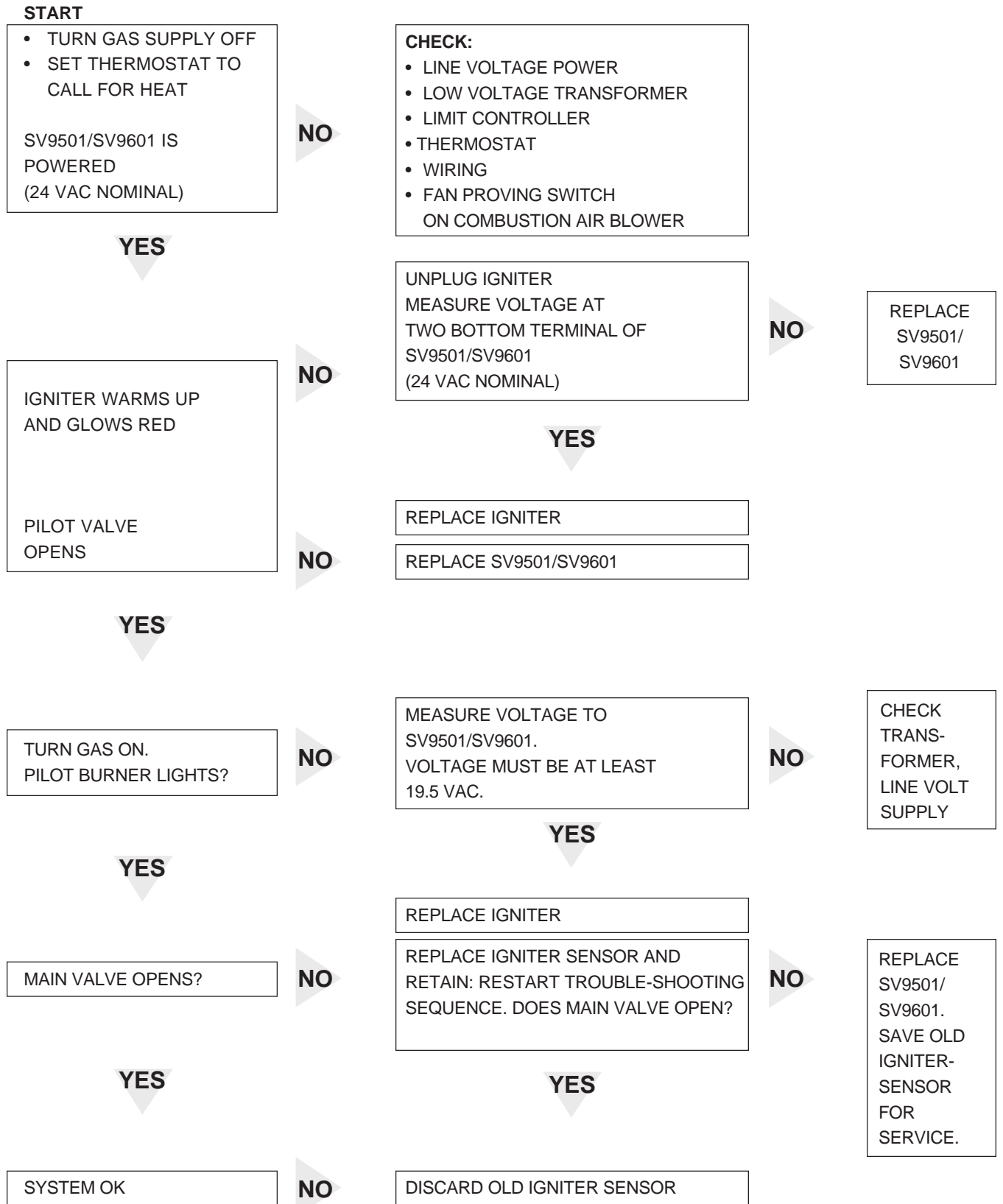

Troubleshooting Honeywell S8600 Intermittent Pilot System (Spark Ignition)

Some models are equipped with lockout/retry modules. On L.P.G. models, trial for ignition last 15 seconds followed by 5 minutes lockout, then the cycle repeats.

START

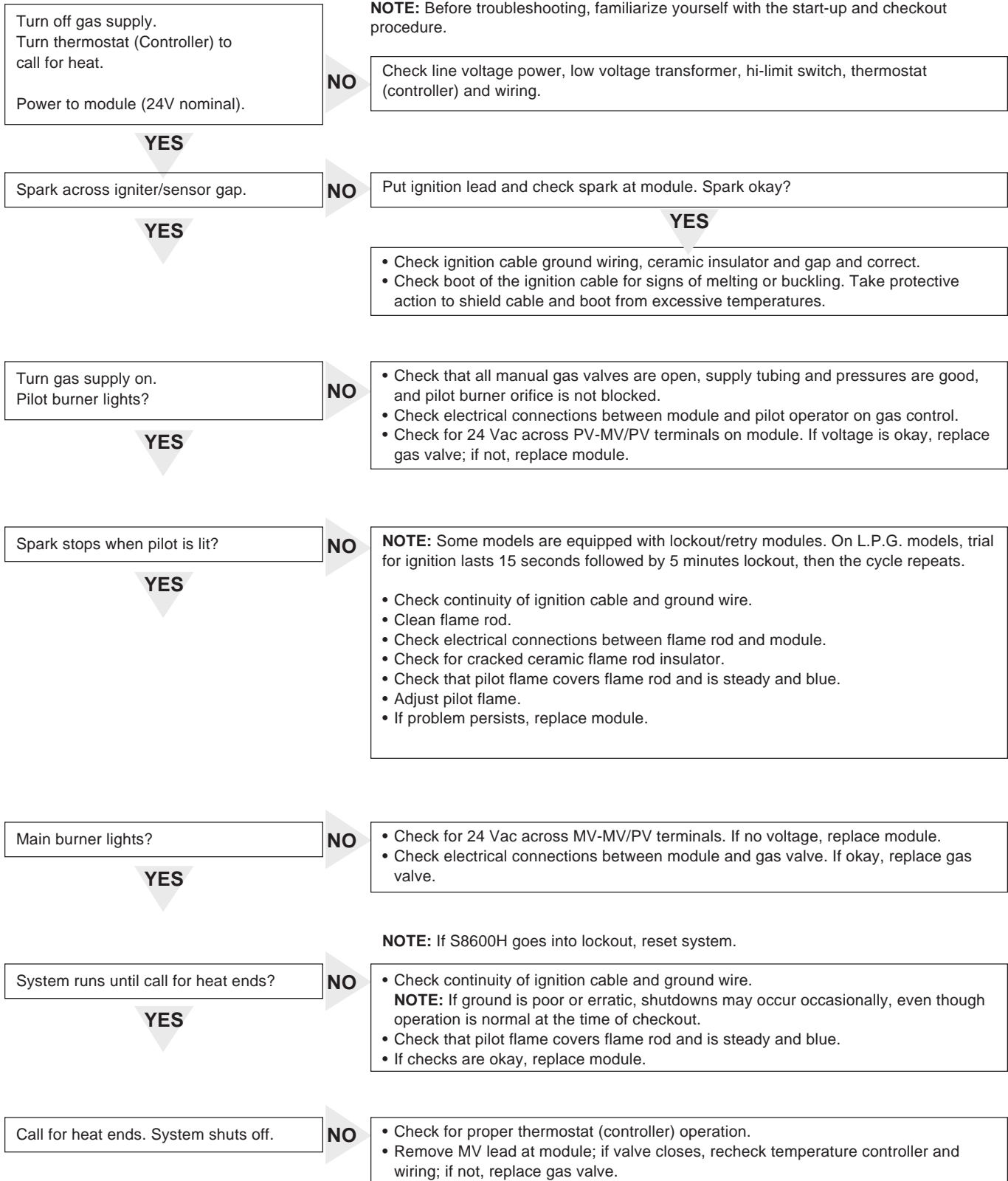

Glossary of Terms

Air Vent

A device used to purge air from the Circuit. Should be located at the highest point in the Circuit.

Branch

The section(s) of supply and return piping, including the heat distribution units connected directly to the trunk. Also referred to as a “zone”.

By-Pass

A section of pipe (including an adjustable valve) that diverts part of the water flow from undersized piping to the boiler. Adjusted to maintain minimum flow requirement (GPM) through the boiler.

Circuit

Entire water circulation piping, beginning and ending at the boiler (Series Loop System).

Expansion Tank (Compression Tank)

Installed in the circuit to accommodate excess water produced by heat expansion.

Heat Distribution Units

Transfers heat from the water supplied by the boiler to the area to be heated through the use of baseboard, convactor, radiator, finned tube. Also known as “radiation”.

Isolation Valve

Used to isolate the boiler from the circuit. It minimizes the amount of water drained from the system.

Primary-Secondary Piping

Two or more interconnecting circulating loops, each with its own pump. Primary =System Circuit; Secondary=Boiler Circuit.

Reverse-Return Piping

Balanced, equal flow (first in, last out) piping. Utilized with multiple boilers and/or radiation. Applied with single system pumps, or primary-secondary pump.

System Purge Valve

A device used to purge air from the circuit. Should be located as close as possible to the cold water feed, but not immediately after the cold water feed.

Trunk

The section of piping which connects the boiler return and supply with the branch(es). Also known as a “main” or “header”. Should be same size as boiler inlet/outlet connections.

Zone Pump

Circulators installed in branch piping that divert hot water coming from the boiler into various areas (zones) of a building.

Zone Valve

Diverts hot water from the boiler into various areas (zones) of a building.

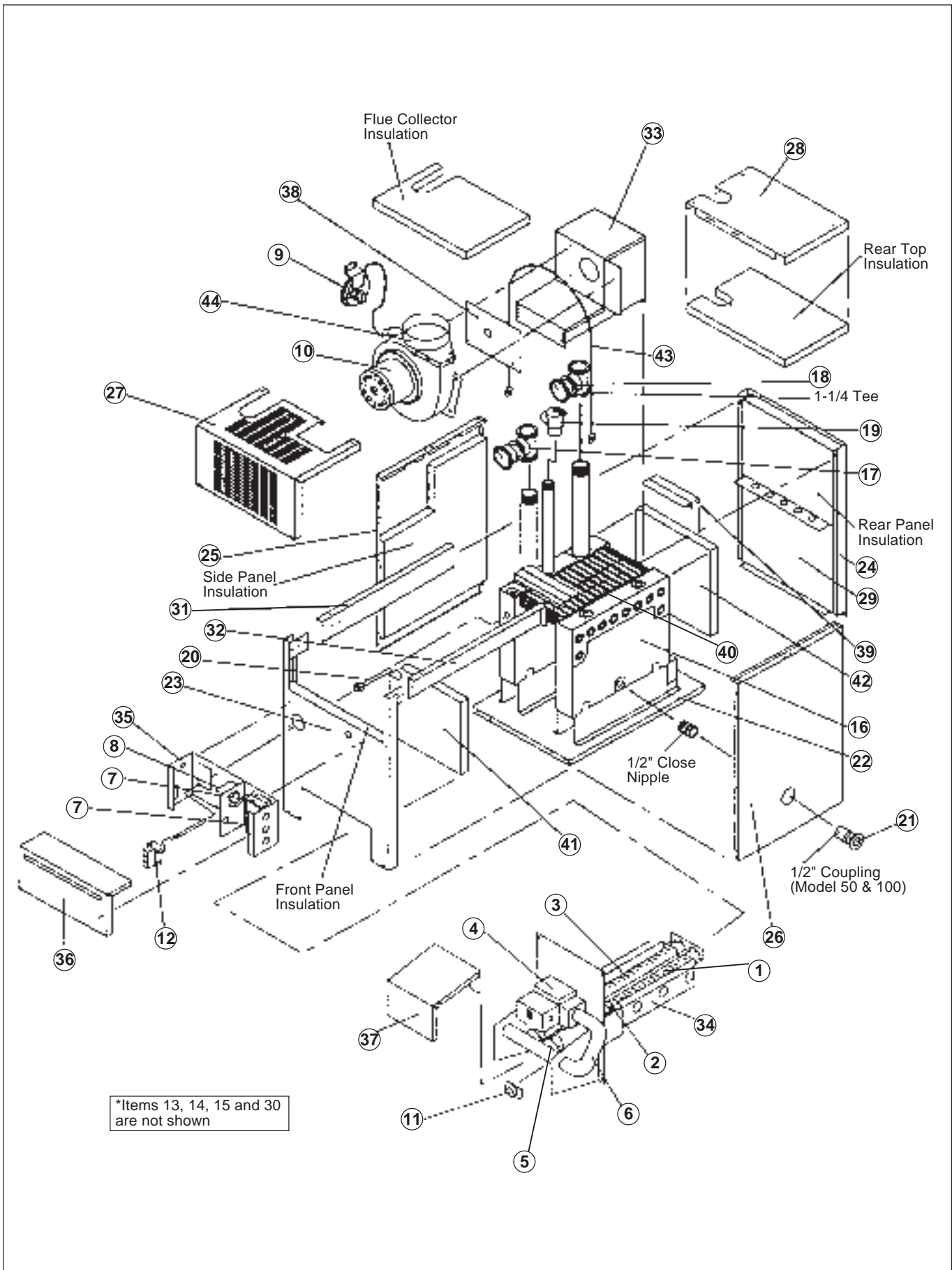

Figure 15. Parts Identification.



H2020900C



Waterpik Technologies, Inc.
6000 Condor Drive, Moorpark, CA 93021 • 805.529.2000 • FAX 805.529.5934
20 Industrial Way, Rochester, NH 03867 • 603.335.6300 • FAX 603.335.3355
480 S. Service Road West, Oakville, Ontario, Canada L6K 2H4 • 905.844.8233 • FAX 905.844.2635
www.laars.com

Litho in U.S.A. © Laars Heating Systems 0005 Document 1080C