

Installation
and Operation
Instructions for

Mini-Combo II

(Models MCT, MCS)
Residential Gas-Fired
Space/Water Heater

NOTE: This manual is to be used in conjunction with Document 1025, Installation and Operation Instructions for Mini-Therm II JV boilers.

FOR YOUR SAFETY: This product must be installed and serviced by a professional service technician, qualified in hot water heater installation and maintenance. Improper installation and/or operation could create carbon monoxide gas in flue gases which could cause serious injury, property damage, or death. Improper installation and/or operation will void the warranty.

⚠ WARNING

If the information in this manual is not followed exactly, a fire or explosion may result causing property damage, personal injury or loss of life.

Do not store or use gasoline or other flammable vapors and liquids in the vicinity of this or any other appliance.

WHAT TO DO IF YOU SMELL GAS

- Do not try to light any appliance.
- Do not touch any electrical switch; do not use any phone in your building.
- Immediately call your gas supplier from a nearby phone. Follow the gas supplier's instructions.
- If you cannot reach your gas supplier, call the fire department.

Installation and service must be performed by a qualified installer, service agency, or gas supplier.

TABLE OF CONTENTS

SECTION 1.

General Information

1A. Introduction 3

SECTION 2.

Installation

2A. Location 3
2B. Heater Placement 3
2C. Piping 5
2D. Wiring 5, 6, 7
2E. Sequence of Operation 9

SECTION 1. General Information

WARNING

This manual supplies information on the application, installation and operation of the indirect water heater unit. A complete instruction manual of the operation of the hydronic boiler (Document 1025) is supplied along with this manual. Both manuals should be reviewed completely before proceeding with the installation.

- Failure to follow the instructions provided may result in personal injury, death or substantial property damage.
- Any modifications to the boiler, water tank, gas and water connections, or wiring may void warranty.
- Consult the factory or local factory representative with any questions or problems regarding this equipment.

Hazards and Your Safety - Hot Water Can Scald!

Consumer Product Safety Commission and some states/provinces recommend a temperature setting of 130°F (54°C) or less. The water heater thermostat is factory set to approximately 120°F (49°C). If thermostat will be set above factory setting, install an anti-scald valve at either the water heater or at each hot water faucet.

- Tempering valves are not anti-scald valves since they do not have a positive shutoff in case cold water supply fails. They are not recommended for shower/tub service. If needed, install an anti-scald valve at each shower/tub.
- Water heated to a temperature suitable for clothes washing, dish washing and other sanitizing needs can scald and cause permanent injury.
- Children and elderly, infirm, or physically handicapped persons are more likely to be injured by hot water. Never leave them unattended in a bathtub or shower. Never allow small children to use a hot water tap or draw their own bath. If anyone using hot water in the building fits this description, or if state/province laws or local codes require certain water temperature at hot water taps, take special precautions:

Install an anti-scald valve at water heater or at each hot water faucet, bath, and shower outlet.

Use lowest practical temperature setting.

- Studies have indicated that dangerous bacteria can form in potable water distribution system if certain minimum water temperatures are not maintained. Contact local health department for more information.

SECTION 2. Installation

This installation must conform with the instructions in this manual and, where applicable:

Local, state, provincial, and national codes, laws, regulations and ordinances.

In Canada - CAN/CGA B149.1 or B149.2 installation Code.

Where the recommendations made in this manual differ from local or national codes, the local or national codes take precedence.

2A. Location

This water heater/boiler unit is not intended for outdoor installation. Select a convenient location where water leakage from the tank or connections will not result in damage to areas adjacent to the appliance or to lower floors of the structure. When a safe location cannot be found, install a suitable drain pan under the appliance, and pipe it to an adequate drain.

2B. Heater Placement

The heater must be placed to provide clearances on all sides for maintenance and inspection. Allow 4 inches (102mm) on each side for piping access. There must also be minimum distances maintained from combustible surfaces. Figure 2 shows minimum clearance from combustible surfaces. The Mini-Combo unit can be installed in a closet, as long as the minimum clearances are maintained. Special attention should be paid to the air supply opening to the closet. Refer to Table 1.

Net Free Area - square inches <i>sq. mm</i>		
Model	Inside Air	Outside Air
MC50	100 645	15 97
MC75	100 645	20 129
MC100	100 645	25 161
MC125	125 807	32 207

Area indicated is for one of two openings: One at floor level and one at the ceiling, so the total free area would be double the figures indicated. Refer to Document 1025 for more information

Table 1. Minimum Recommended Air Supply.

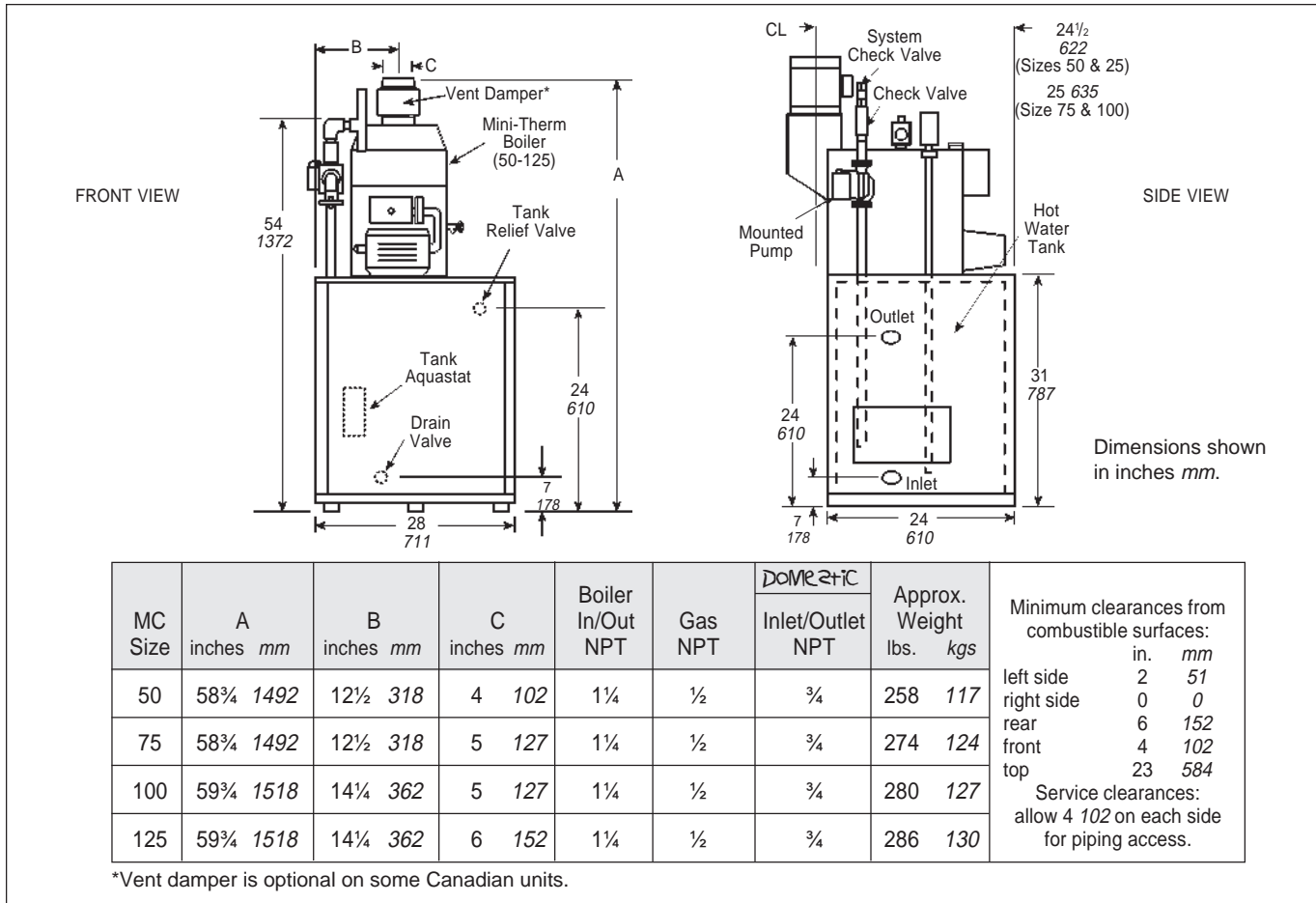

Figure 1. Dimensional Information.

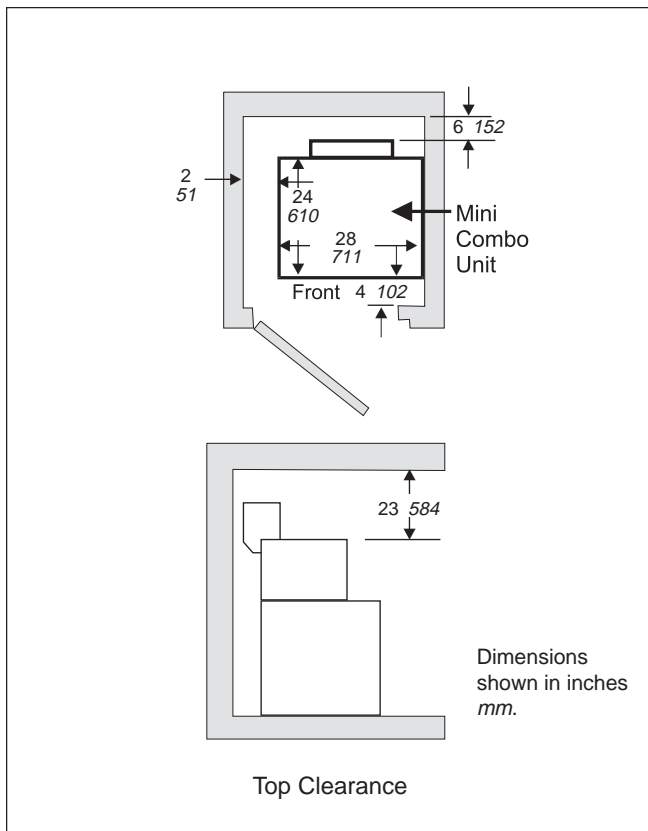

Figure 2. Closet Installation.

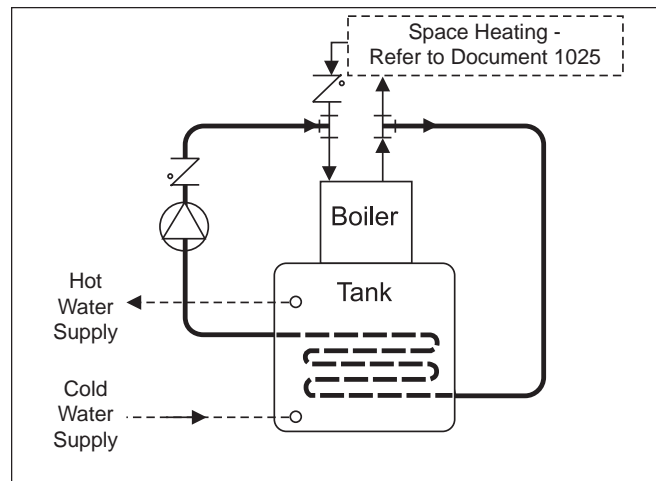

Figure 3. Piping Schematic.

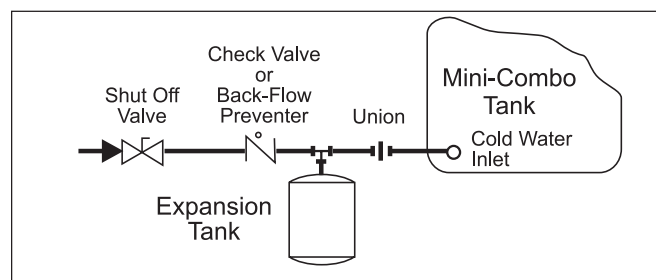

Figure 4. Typical Expansion Tank Installation.

2C. Piping

- To Prevent damage to the unit, all soldering is to be done prior to assembling the cold and hot water, and any other connections to the tank.
- Use suitable pipe dope or tape.
- Before piping the boiler to the heating system, be sure to install the system check valve (provided with the unit) onto the inlet (return) tee of the boiler with arrow pointed downward (see Figure 3).
- If anti-freeze is used in boiler system, local codes may require a backflow preventer on cold supply line. Use anti-freeze specifically intended for hydronic heating system. Inhibited propylene glycol is recommended.

WARNING

Do not use automotive or ethylene glycol anti-freeze, or any undiluted anti-freeze. This can cause severe personal injury, death or substantial property damage.

If a backflow preventer, pressure reducing valve or check valve is in cold water supply, install an expansion tank on cold water supply line (Figure 4) to prevent normal thermal expansion from repeatedly forcing open the T&P relief valve.

T&P relief valves discharge piping must be directed so that hot water flows away from all persons. Attach run-off tube to T&P valve and run tube within 6" (152mm) from floor. No reducing couplings, valves, or any other type of restriction is to be installed in this line. This run-off tube must be installed to allow free and complete drainage of both valve and run-off tube.

Filling Storage Water Tank

1. Open hot water faucet in house to allow air in the tank and in piping to escape.
2. Open shut-off valve(s) in cold water supply line.
3. Open shut-off valve(s) in hot water supply line.
4. When water discharges from the faucet, close it. Check for system leaks and repair if necessary.

Filling and connecting boiler pipes:

Consult the JV boiler manual, Document 1025.

Caution

Never use water heater/boiler unless it is completely filled with water.

2D. Wiring

Priority System: Under this wiring the storage tank will be supplied before space heating. This will insure that it gets adequate hot water flow from the boiler to maintain a fully rated delivery of domestic hot water.

Caution

In this priority mode, any demand for space heating is postponed until the storage water tank has reached set temperature. This delay in supplying the space heating zones is usually not noticed by the inhabitants of the living spaces. However, in the event of certain storage water tank malfunctions, space heating could be delayed indefinitely. If undetected and uncorrected, freezing damage to piping could result.

WARNING

Electrical shock can cause severe personal injury or death. Disconnect power supply to the boiler before doing any electrical work.

Electrical Connection: (See Figure 5, 6 and 7)

1. Remove the two screws attaching the front cover of the control box.
2. There are five wires coiled in the area on the right side of the control box, supplied with wire nuts: 2 black wires twisted together, 2 white wires twisted together, and a brown wire.
3. Follow Figures 5, 6 and 7. Remove the wire nut from the two black wires, and connect the hot lead from a 115 volt power supply to both wires. Secure the three wires with the wire nut.
4. The two white, neutral wires should be joined to the other neutral lead coming from the 115 volt power supply, and the neutral lead coming from the pump (space heating).
5. The brown wire attaches to the hot side of the space heating pump.
6. There is a molex connector located on the left side of the control panel. Connect the vent damper harness to the molex connector and the other end to the vent damper receptacle.

NOTE: The connection in step 6 should remain intact at all times, otherwise the boiler will not fire.

Some Canadian units are supplied with vent damper jumper plug. Do not remove jumper unless vent damper is to be installed.

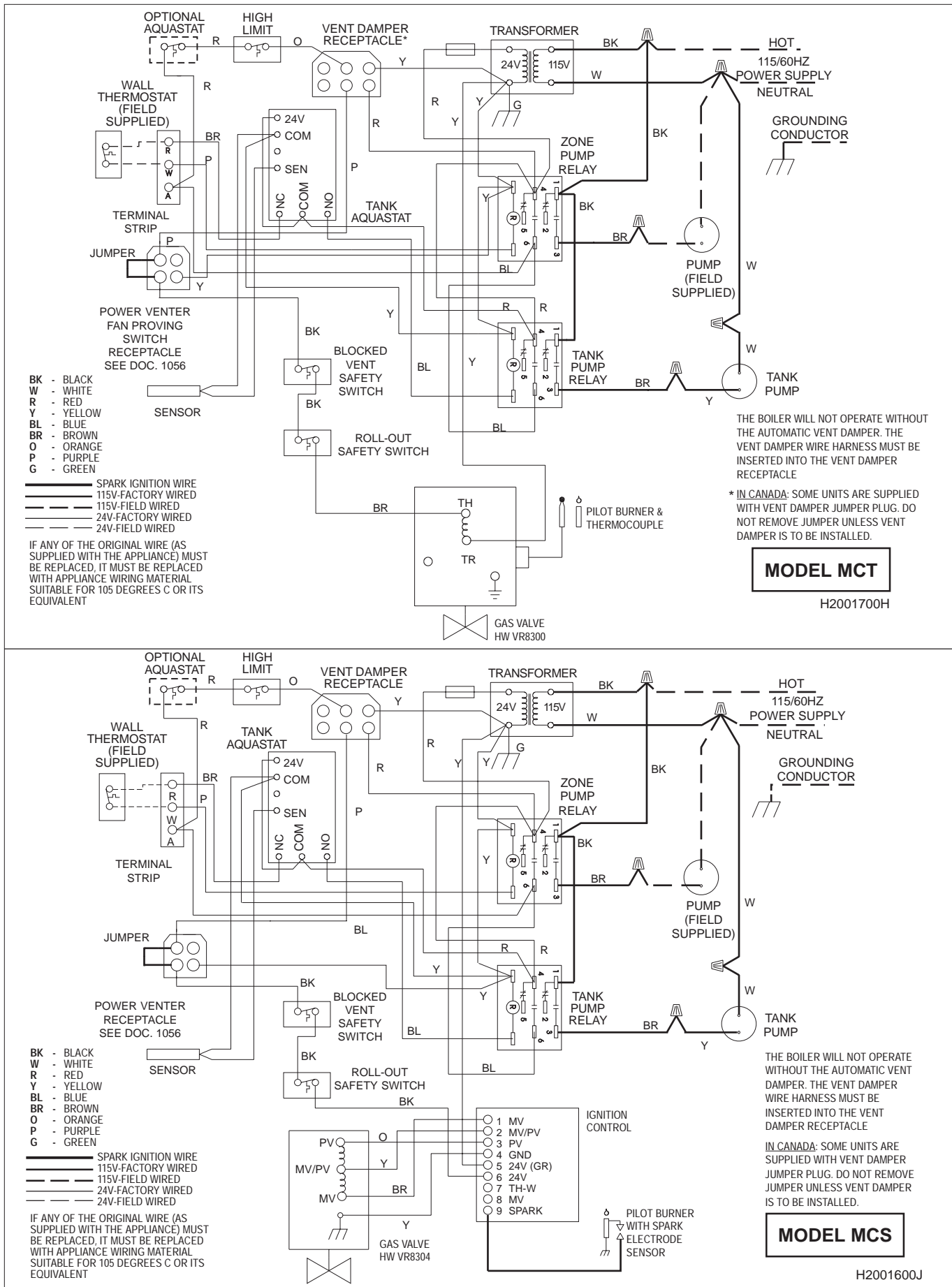
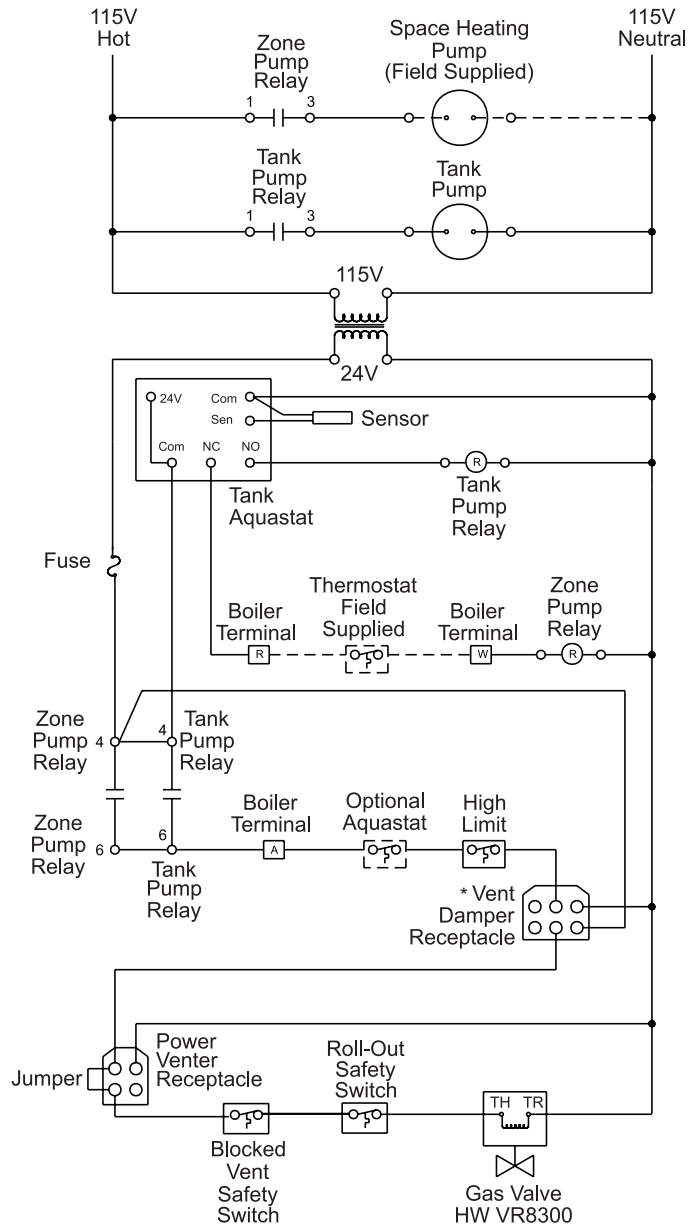
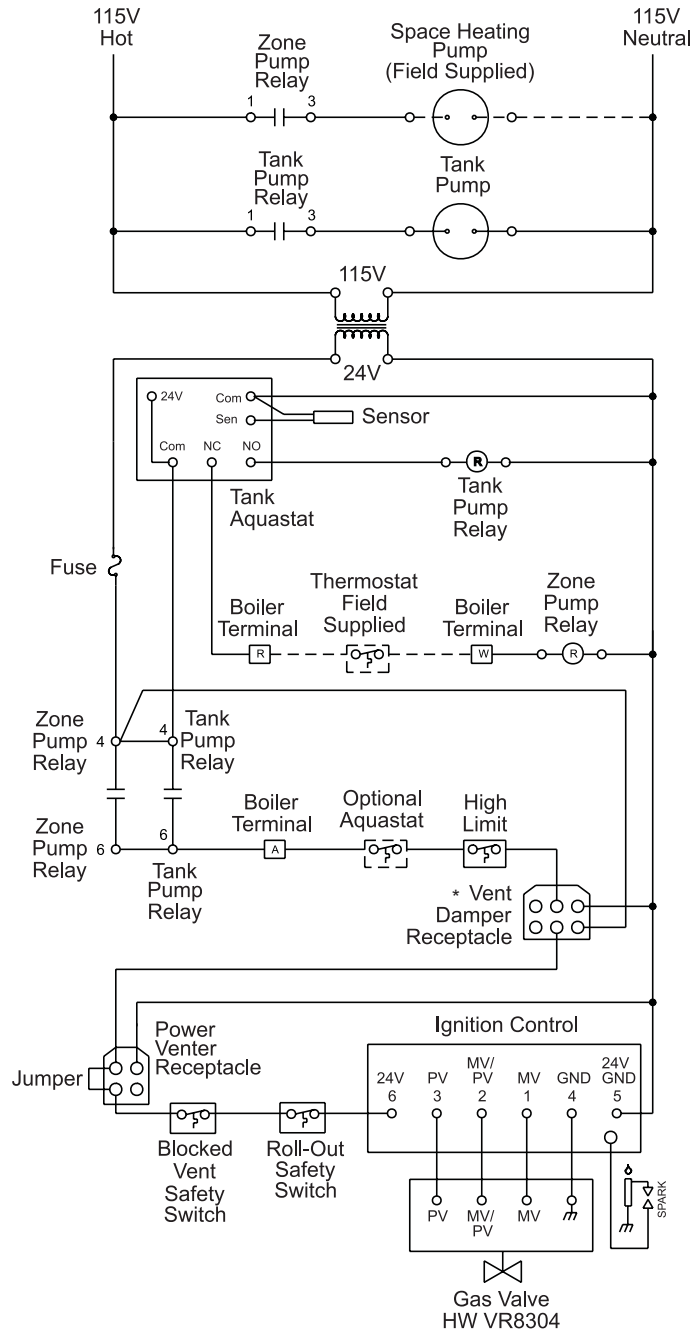

Figure 5. Wiring Diagrams.



*Some Canadian units are supplied with vent damper jumper plug. Do not remove jumper unless vent damper is to be installed.

Figure 6. MCT Schematic.



*Some Canadian units are supplied with vent damper jumper plug. Do not remove jumper unless vent damper is to be installed.

Figure 7. MCS Schematic.

2E. Sequence of Operation

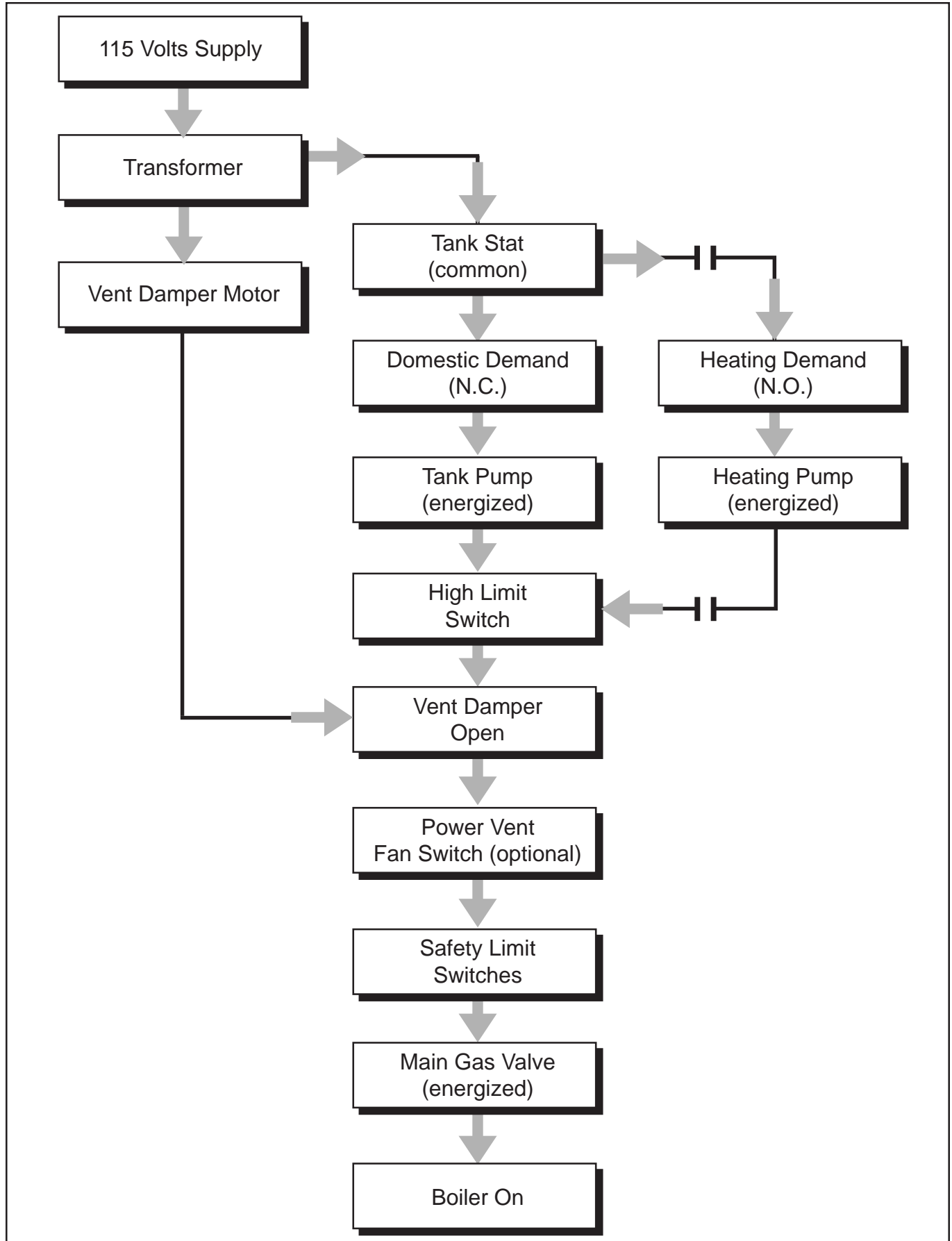

Figure 8. Sequence of Operation.

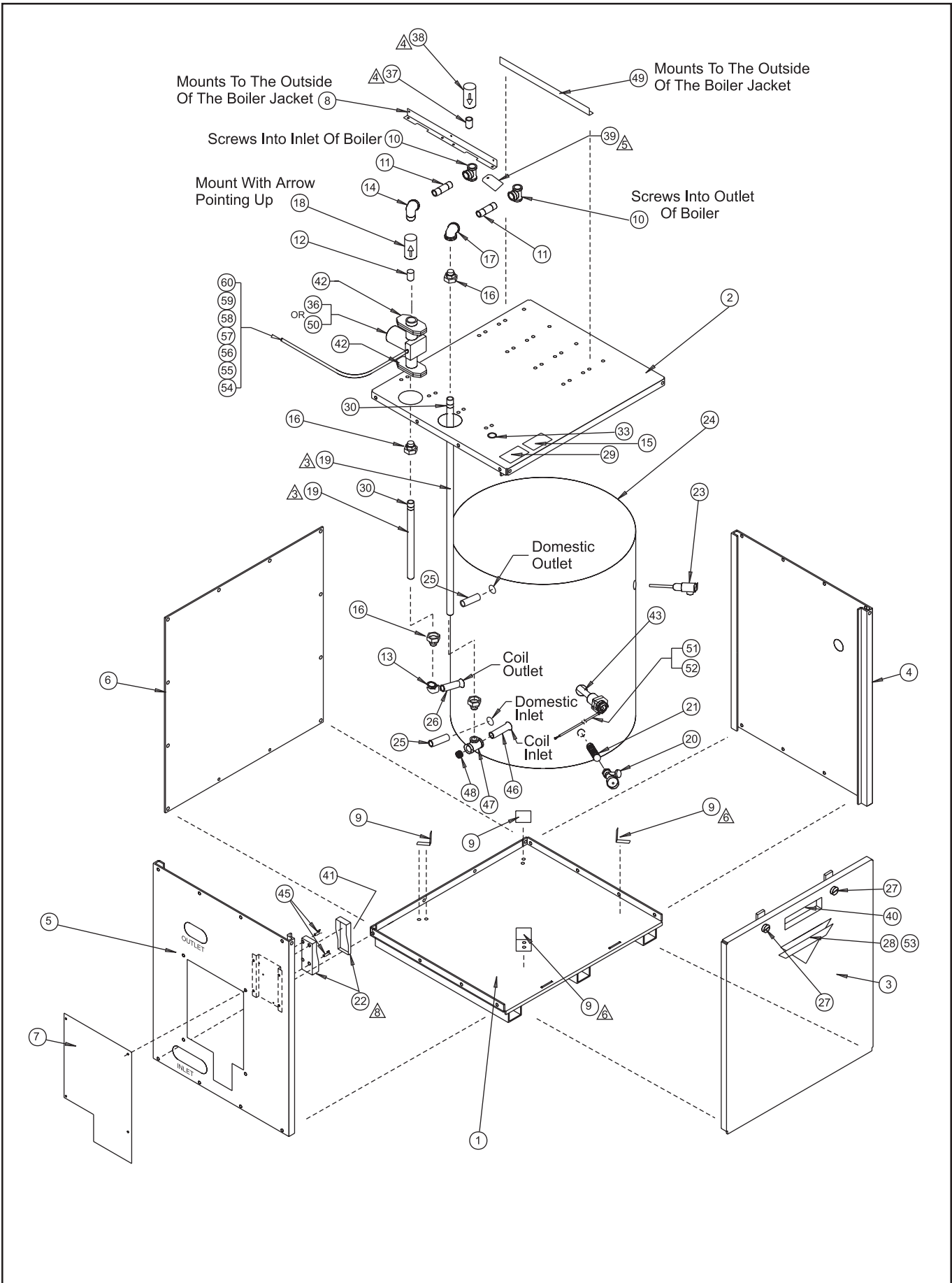

Figure 9. Parts Identification.

#	Qty	Part #	Description
1	1	20085700	Weldment, Panel, Base
2	1	20085600	Weldment, Panel, Top
3	1	20086300	Weldment, Panel, Door
4	1	20086400	Panel, Side, Right
5	1	20127900	Weldment, Panel, Side, Left
6	1	20085900	Panel, Rear
7	1	20086500	Panel, Access
8	1	20084000	Bracket, Mounting, Left
9	4	20085400	Bracket, Support, Tank
10	2	P2015400	Tee, Blk, 1¼" x 1¼" x ¾" NPT
11	2	P0014400	Nipple, Black, ¾" NPT x 2.5" LG
12	1	P0014100	Nipple, Close, ¾" NPT
13	1	P2016900	Elbow, Blk, 90°, ¾" x 1" NPT
14	1	P0009300	Elbow, Street, Blk, ¾" NPT
15	1	H2078100	Label, Attention, Toxicity
16	4	P2014800	Fitting, Compress, 7/8" OD x ¾" NPT
17	1	P0008300	Elbow, Blk, 90°, ¾" NPT
18	1	A2085600	Valve, Check, ¾" NPT
19	6 ft.	P2015000	Tubing, Copper, Type "L" 7/8" OD
20	1	A2085700	Valve, Drain, Tank, ¾" NPT
21	1	P0025300	Nipple, Brass, ¾" NPT x 2" LG
22	1	E0205000	Temperature Control, Electronic
23	1	A2085400	Valve, Relief, Temp & Pressure
24	1	A2085300	30 Gal Water Tank, Single Wall HX
	1	A2085301	30 Gal Water Tank, Double Wall HX
25	2	Field Supplied Nipple, Brass ¾" NPT x 4" LG	
26	1	Field Supplied Nipple, Brass 1" NPT x 3" LG	
27	2	20087300	Door Latch Assembly
28	1	H2020600	Logo, Mini-Como II
29	1	H2016800	Label, Warning, Installation
30	2	H0090700	Label, Hot
31		not shown	part not sold
32	56	F0024300	Screw, 10-16 x 5/8" LG
33	1	S0064900	Bushing, Nylon, Univ, 7/8" Dia.
36	1	A0066500	Pump, circulator, 1/25 HP
37	1	P0017100	Nipple, Close, Blk, 1¼" NPT
38	1	A2086600	Valve, Check, 1¼" NPT
39	1	H2017100	Tag, Important, Check Valve
40	1	A2087600	Handle, Door
41	1	H2017800	Label, Caution, Setting, Temp
42	2	A2086700	Flange, Pump, ¾" NPT
43	1	Vendor Supplied Well, Immersion, ¾" NPT	
45	2	F0035900	Screw, #6-32 x 5/8" LG, Phillips, Rnd Hd
46	1	Vendor Supplied Nipple, Brass 1" NPT x 2" Long	
47	1	P0095000	Tee, 1" x 1" x ¾", Black Iron
48	1	P0071400	Plug, 1" Stainless Steel w/Vibroseat
49	1	20084001	Bracket, Mounting, Right
50	1	A2001500	Pump, Taco, 220V
51	1	E2103100	Sensor, Temperature
52	1	Q0068400	Tubing, Aluminum, 5"
53	2	F0035600	Nut, Speed, Push On
54	4¼ ft	E0020900	Conduit, Flex, 3/8"
55	2	E0008300	Nut, Conduit, Lock
56	2	E0008100	Conduit Connector, 3/8"
57	5	E0007700	Wire Nut, 2 #4 Wires
58	4½ ft	E0052500	Wire, #18 AWG 3/64", Yellow
59	4½ ft	E0051900	Wire, #18 AWG 3/64", White
60	2	E0036100	Bushing
61	1	E0088400	Relay
62	1	E0097700	Relay, Case and Cover



Waterpik Technologies, Inc.
6000 Condor Drive, Moorpark, CA 93021 • 805.529.2000 • FAX 805.529.5934
20 Industrial Way, Rochester, NH 03867 • 603.335.6300 • FAX 603.335.3355
480 S. Service Road West, Oakville, Ontario, Canada L6K 2H4 • 905.844.8233 • FAX 905.844.2635
www.laars.com