

Installation,
Operation and
Maintenance
Instructions for

MAX

Residential
Oil-Fired Boiler

Models (D) MAX 75
(D) MAX 100
(D) MAX 120
(D) MAX 140
(D) MAX 165

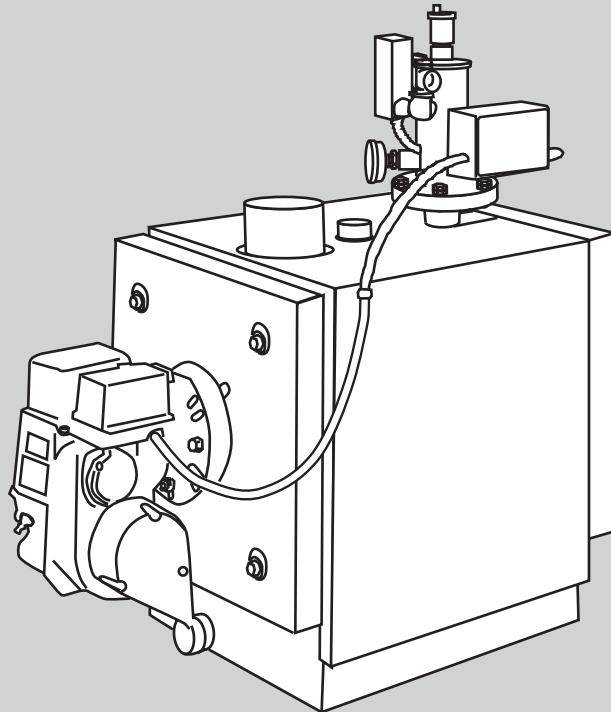

FOR YOUR SAFETY: This product must be installed and serviced by a professional service technician, qualified in hot water heater installation and maintenance. Improper installation and/or operation could create carbon monoxide gas in flue gases which could cause serious injury, property damage, or death. Improper installation and/or operation will void the warranty.

⚠ WARNING

If the information in this manual is not followed exactly, a fire or explosion may result causing property damage, personal injury or loss of life.

Do not store or use gasoline or other flammable vapors and liquids in the vicinity of this or any other appliance.

WHAT TO DO IF YOU SMELL GAS

- Do not try to light any appliance.
- Do not touch any electrical switch; do not use any phone in your building.
- Immediately call your gas supplier from a nearby phone. Follow the gas supplier's instructions.
- If you cannot reach your gas supplier, call the fire department.

Installation and service must be performed by a qualified installer, service agency, or gas supplier.

TABLE OF CONTENTS

SECTION 1.

General Information

1A. Introduction 3

SECTION 2.

Technical Specifications

2A. Boiler Outputs 3

SECTION 3.

Installation

3A. Freight Claims 5
 3B. Regulations 5
 3C. Sizing the System 5
 3D. Location 5
 3E. Clearance 6
 3F. Combustion Air (other than direct vent) 6
 3G. Ventilation Air (conventional chimney
 and direct vent) 6
 3H. Chimney Connection 6
 3I. Direct Vent Balanced Flue System 6
 3J. Installation of Balanced Flue System 7
 3K. Boiler Piping 8
 3L. Indirect Hot Water Tank 9
 3M. Burner Controls 9

3N. Fuel System (oil supply #2 fuel oil) 9
 3O. Gravity Head System 9
 3P. Suction Lift System 9
 3Q. Oil Filter 9
 3R. Wiring 9

SECTION 4.

Operation

4A. Preliminary Burner Settings 10
 4B. Burner Adjustments 10
 4C. Sequence of Operation 11

SECTION 5.

Maintenance

5A. Boiler 22
 5B. Oil Burners 22
 5C. Oil Filter 22

SECTION 6.

Homeowner Information

6A. General Information 22

SECTION 7.

Part Numbers

..... 24

SECTION 1. General Information

1A. Introduction

The MAX Boiler has been constructed to meet the stringent requirements of the ASME Boiler Codes and designed to provide a rapid response to hot water and heating demands at a very high thermal efficiency.

This is a low mass boiler. To take advantage of this feature, and prevent short cycling, always select the lowest firing rate satisfactory for the load requirement.

The boiler is supplied either for connection to a conventional chimney or comes complete with a balanced flue system for direct venting through the wall.

With the balanced flue system, air for combustion is drawn from outside through a terminal and ducted directly to the burner, making the boiler virtually room sealed. Flue gases are discharged through the same terminal so that wind pressures are applied equally to inlet and outlet, making it a true balanced flue system. A silencer is also incorporated in the terminal to reduce the flue gas discharge noise. This is a particularly useful feature if the terminal is located near a bedroom window or adjacent to neighboring properties.

The boiler is constructed with two concentric water jackets, the inner one forming the furnace tube and the outer the flue gas annulus. Flue gas retarders fitted around the annulus are specially designed to extract the maximum heat from the gases with minimum pressure loss.

The simple annular design also makes it possible to keep the water content to a minimum (only 3.2 gals. [12L] for the (D)MAX 75, 100, 120 and 5.1 gals. [19L] for the (D)MAX 140, 165). Because of this low mass, water is rapidly heated to the temperature demands. Another benefit of the low thermal mass is the insignificant level of standby loss when the burner shuts down.

To achieve the best possible heat transfer, the boiler is designed on the "Series Flow" principle whereby the return water is preheated by first passing through the outer water annulus before coming into

contact with the furnace tube. This arrangement also provides a counter flow of flue gases and water so that the coolest gases come into contact with the coolest water for the most efficient heat transfer.

Heavily insulated doors at front and back of boiler, provide easy access for cleaning and inspection, with the burner being swung on the front door either left or right as required.

Accurate sensing of temperature and pressure is assured by grouping all controls and safety devices on a common supply manifold.

The use of the latest flame retention head burner allows the boiler to operate under a slight positive pressure which ensures stable combustion under virtually all operating conditions.

SECTION 2. Technical Specifications

2A. Boiler Outputs

Boiler constructed and hydrostatically tested in accordance with ASME Boiler code Section IV.

Beckett AFII 150 / Carlin EZ1 Oil Burner complete with flame retention head, Honeywell control and cad. cell. or equivalent

(A post purge timer and oil solenoid valve is fitted to direct vent burners)

Honeywell L8148A Aquastat Relay.

Honeywell L.4006E High Limit Aquastat (manual reset - direct vent boilers only)

Temperature and pressure gauge.

Pressure relief valve 3/4"

Automatic air vent

Air eliminator built into supply manifold

Boiler drain valve 1/2"

Balanced Flue System Kit (direct vent boilers only)

1 - "Univent" balanced flue terminal silencer
10 - 15 ft. (3-4.5m) of 4" dia. flexible aluminum pipe (air supply)

10 - 15 ft. (3-4.5m) of 5" dia. flexible stainless steel pipe (flue gas)

(D) MAX Model	GPH Input Rate	Nozzle Size GPH	Pump Pressure P.S.I.	Input MBTH/hr	AFUE Rating %	Heating Capacity BTU/hr	Water Content		Shipping Weight	
							gal.	(L)	lbs.	(kg)
75	0.75	0.65	140	105	87.0	91,350	3.2	12	324	147
100	1.00	0.85	140	140	86.5	121,400	3.2	12	324	147
120	1.20	1.00	140	150	86.0	144,800	3.2	12	324	147
140	1.40	1.25	150	196	85.6	169,344	5.1	19	431	196
165	1.65	1.35	150	231	85.0	196,350	5.1	19	431	196

Table 1. Boiler Specifications.

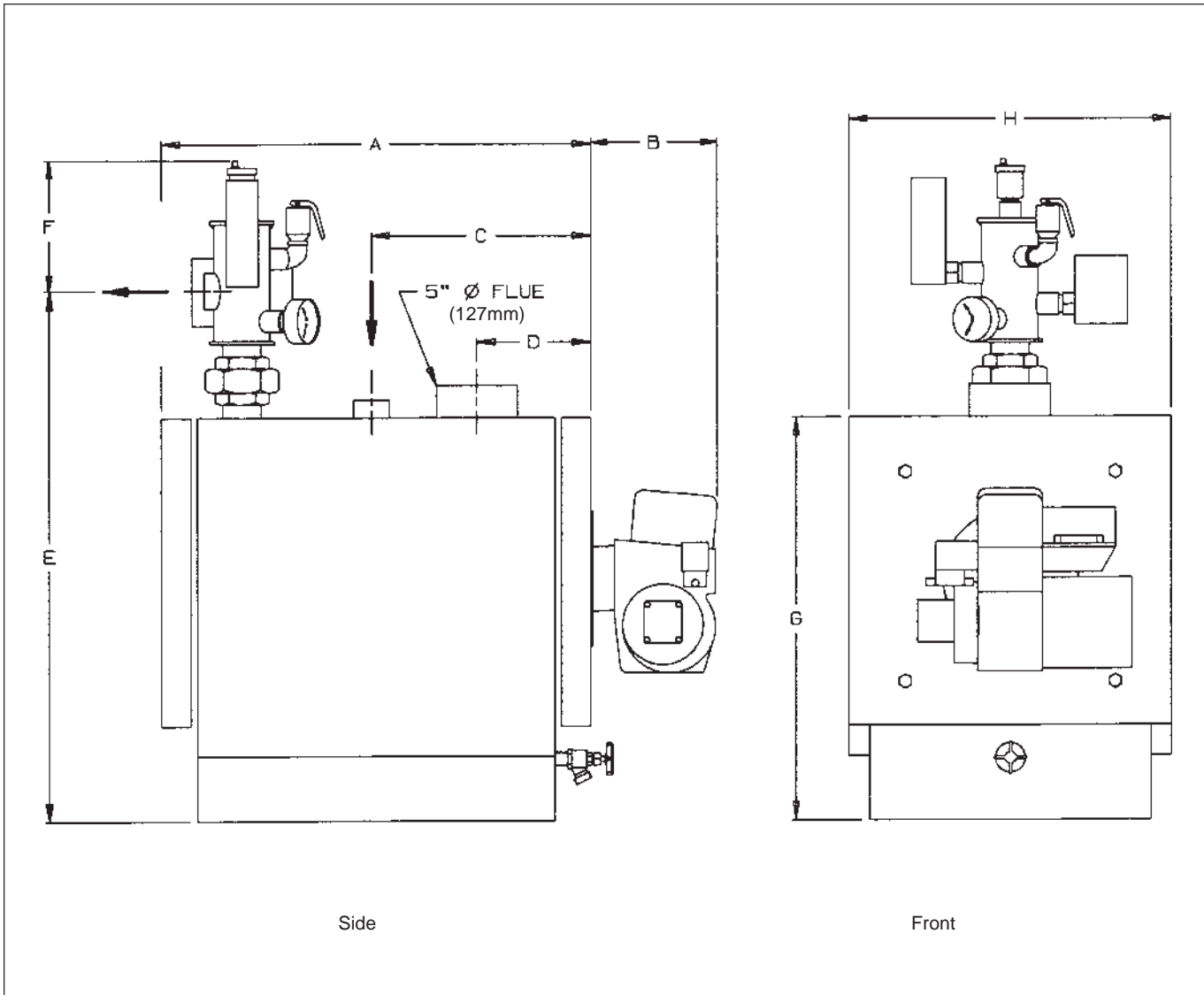

Figure 1. Boiler Dimensions (refer to Table 2).

Dimensions	Ref	MAX 75		MAX 100		MAX 120		MAX 140		MAX 165	
		in.	mm	in.	mm	in.	mm	in.	mm	in.	mm
Jacket Length	A	26½	673	26½	673	26½	673	27¾	705	27¾	705
Burner Length (Beckett)	B	8¾	222	8¾	222	8¾	222	8¾	222	8¾	222
Burner Length (Carlin)	B	14	356	14	356	14	356	14	356	14	356
Return Tapping Location	C	13½	343	13½	343	13½	343	12¾	324	12¾	324
Smoke Outlet Location	D	7	178	7	178	7	178	7	178	7	178
Supply Tapping Location	E	32¾	832	32¾	832	32¾	832	39¼	997	39¼	997
Overall Height (E+F)	F	8¾	210	8¾	210	8¾	210	8¾	210	8¾	210
Jacket Height	G	25	635	25	635	25	635	30¼	768	30¼	768
Jacket Width	H	20	508	20	508	20	508	24½	622	24¼	622
Smoke Outlet Diameter		5	127	5	127	5	127	5	127	5	127
Supply Tapping Diameter		1¼	32	1¼	32	1¼	32	1¼	32	1¼	32

Table 2. Boiler Dimensions.

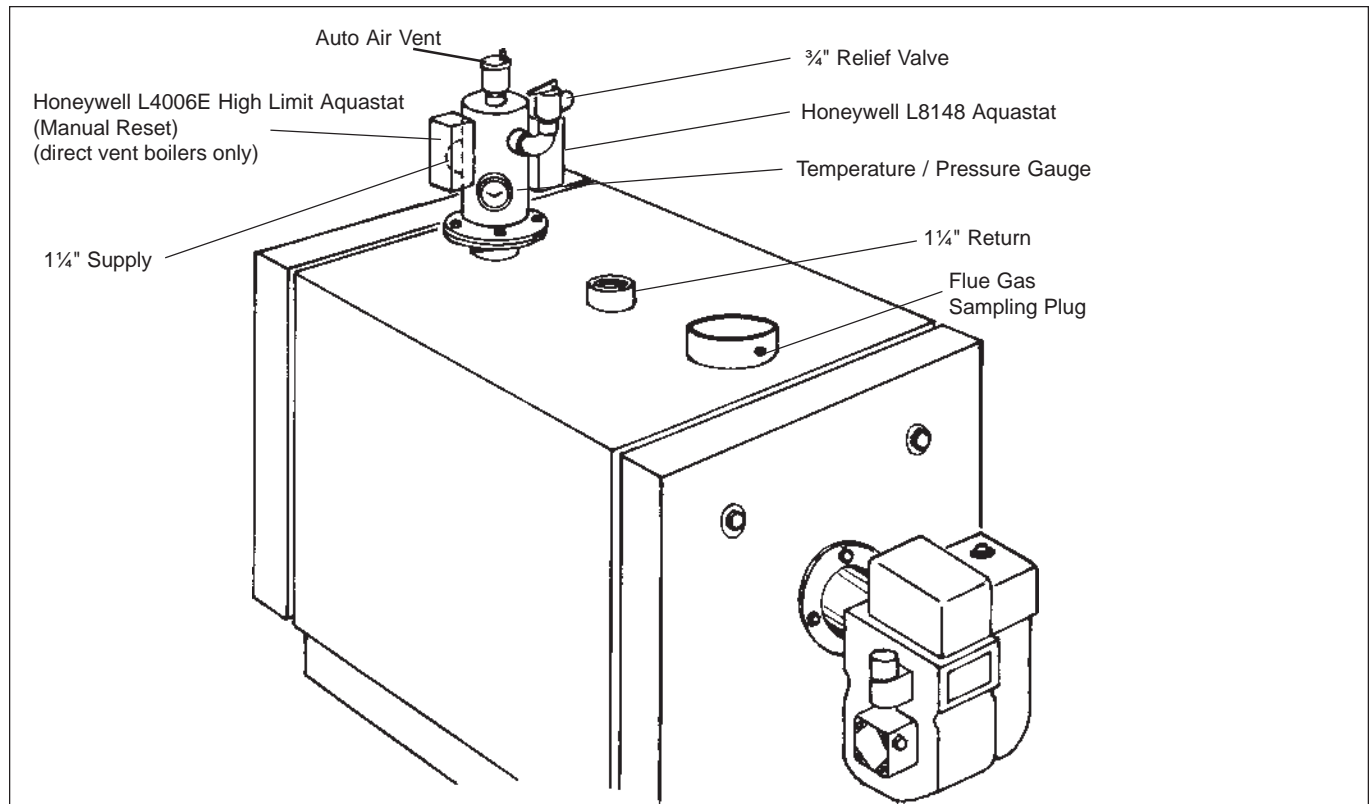

Figure 2. Controls Layout.

SECTION 3. Installation

3A. Freight Claims

The boiler and its components should be inspected for damage upon arrival and any claim filed immediately against the carrier by the consignee. The carrier is responsible for taking prompt action on all claims.

3B. Regulations

The boiler installation must be carried out by a qualified installer in accordance with the regulations of ANSI / NFPA 31 Installation of Oil Burning Equipment - latest edition, the National Electrical Code ANSI / NFPA 70 - latest edition and local codes and authorities having jurisdiction. Such applicable requirements take precedence over the general requirements contained herein.

The installer must also be properly licensed and experienced in all the codes and ordinances.

⚠️ WARNING

In the interest of safety, gasoline or other flammable fluids or vapors must not be stored or used in the vicinity of the boiler.

3C. Sizing the System

Over sizing the boiler will cause short cycling and reduce its operational efficiency, so it is recommended that a building heat loss calculation is made to ensure that the correct size boiler is used (see Table 1).

3D. Location

The boiler should be mounted on a solid level floor and located as close as possible to the chimney or the position chosen for the direct vent terminal. The boiler can be mounted on a combustible floor due to its wet base construction, however, a check should be made to ensure the floor is capable of supporting the installed weight of the boiler including its water content.

A closet may be used to enclose the boiler, providing the enclosure is properly vented to ensure the controls do not become overheated (see Ventilation Air section). The boiler must also have the correct amount of air available for combustion when using a conventional chimney (see Combustion Air section).

When installed, the boiler must be level. If necessary use metal shims under the base to level the unit particularly front to back otherwise air could be trapped inside the boiler.

3E. Clearance

Adequate clearance should be allowed around the boiler for cleaning and servicing. The following minimum clearances are recommended:

Front - 24" (610mm) (for hinging door)

Rear - 6" (152mm)

Sides - 6" (152mm)

Clearance from combustible materials should be in accordance with local and national codes.

Guidance is given in the National Fire Protection Bulletin NFPA, Installation of Oil Burning Equipment. All other applicable codes should also be followed.

3F. Combustion Air (other than direct vent)

Chimney Vent: For boilers installed in basements, infiltration may be adequate to provide combustion air. For buildings of exceptionally tight construction, the boiler must be installed in an unconfined space, or in an area which directly communicates with an unconfined space. An unconfined space is a space whose volume is 50 cubic ft. (1.4m³) or more per 1,000 BTU (293kW) of the aggregate input of all appliances in that space. Two openings to the space, one 6" (152mm) from the floor and one 6" (152mm) from the ceiling of the enclosure must be provided. Each opening must have at least 168 square inches (1084 sq.cm) of free area.

Chimney Vent with outside air duct connected directly to burner: In an installation of exceptionally tight construction, intake air may be ducted directly to the burner from the outdoors. On an AF2 burner remove the black air intake shroud to connect the 4" (102mm) aluminium duct (up to 15 equivalent ft. [4.6m] maximum). Terminate the duct on the outside of the building with a suitable protective cover. This cover must be located at least 16" (406mm) above grade or above an anticipated snow line.

On Carlin EZ-1 burners install model # 97406 combustion air intake system.

3G. Ventilation Air (conventional chimney and direct vent)

Where the boiler is installed in a basement there is normally sufficient air infiltration to provide adequate ventilation.

Where the boiler is installed in a closet or otherwise confined space ventilation must be provided to keep the controls from overheating. This is accomplished by providing two openings to the space, one 6" (152mm) from the floor and one 6" (152mm) from the ceiling.

3H. Chimney Connection

The chimney must be inspected and thoroughly cleaned before connecting boiler. Most local codes require the chimney to be lined when using an oil fired boiler in order to protect the bricks and mortar from the condensation produced by modern high efficient boilers.

The chimney must terminate at least 3 ft. (0.9m) above the point where it passes through the roof and be in a position free from down draft.

The boiler should be connected to the chimney with the shortest possible run of 5 in. flue pipe and be located above the chimney base to allow a drop leg for scale accumulation to avoid blocking flue pipe entrance.

Horizontal runs should be pitched up towards chimney at approximately 1/4 inch per foot.

Install balanced damper on chimneys higher than 20 feet (6.1m).

IMPORTANT: Max 75-140 may condense when vented into an outside chimney. To minimize potential for condensing, install either thermostatic union or recirc bypass, shown in Figures 15 and 16.

As the boiler and flue pipe are under slight positive pressure on start-up, it is necessary to seal all pipe joints with high temperature tape or silicone sealant to avoid any flue gas leakage into room.

3I. Direct Vent Balanced Flue System

With this system flue gases are vented directly through the wall and fresh air for combustion is drawn in through the same terminal, thus ensuring wind pressures are equal to the intake and flue gas discharge to create a balanced flue condition.

The terminal also incorporates a silencer to reduce the flue gas discharge noise and a specially designed end cap which throws the flue gases clear of the wall to avoid surface discoloration.

NOTE: If the burner is not correctly adjusted it is possible that surface discoloration may occur. Laars will not accept any responsibility for such discoloration.

The position chosen for the Balanced Flue Terminal must conform to the following guidelines:

1. The terminal shall not be less than 3 ft. (0.9m) above or 10 ft. (3m) horizontally from any forced air inlet into the building.
2. The terminal shall not be less than 4 ft. (1.2m) below, 4 ft. (1.2m) horizontally or 1 ft. (0.3m) above any door, window, or gravity air inlet into the building.
3. The terminal shall not be less than 3 ft. (0.9m) from an inside corner of an L shaped building.
4. The terminal shall not be less than 7 ft. (2.1m) above grade when located adjacent to public walkways.

5. The terminal shall not be less than 2 ft. (0.6m) from an adjacent building.
6. **IMPORTANT:** The terminal shall be located at a height not liable to blockage from leaves, snow or other debris, at least one foot (0.3m) above grade level.
7. The terminal shall be positioned so that flue gases are not directed where they can jeopardize people, overheat combustible structures, or enter buildings.
8. As the balanced flue vent system operates under a slight positive pressure it is essential to seal all flue joints to prevent leakage of flue gases into the building. Vent exhaust piping must be certified pressure venting.
9. Vent terminal should be well away from shrubbery or other obstructions that would prevent free air flow to and from vent terminal. Do not terminate vent under decks, stairways, or car ports. When ever possible, locations under windows should be avoided.

10. Vent termination should not be mounted directly above or within 3' horizontally from an oil tank vent.

3J. Installation of Balanced Flue System

1. Having decided the location for the terminal, cut a hole in wall 7.5" high x 10.5" wide (191 x 267mm).
2. Insert terminal through the hole from outside and screw to wall at the fixing flange, after applying a bead of silicone sealant on the back face of the flange.
3. Fit the 5 in. flexible pipe between end of terminal and boiler flue outlet, cutting pipe to suit installation. Secure both ends of pipe with clamps and seal with silicone sealant to prevent any flue gas leakage.

The pipe should rise from the boiler to terminal and be supported at regular intervals dependent upon length of pipe used.

Terminal must be installed pitching down to outside 1/4" per foot to prevent rain entering vent piping.

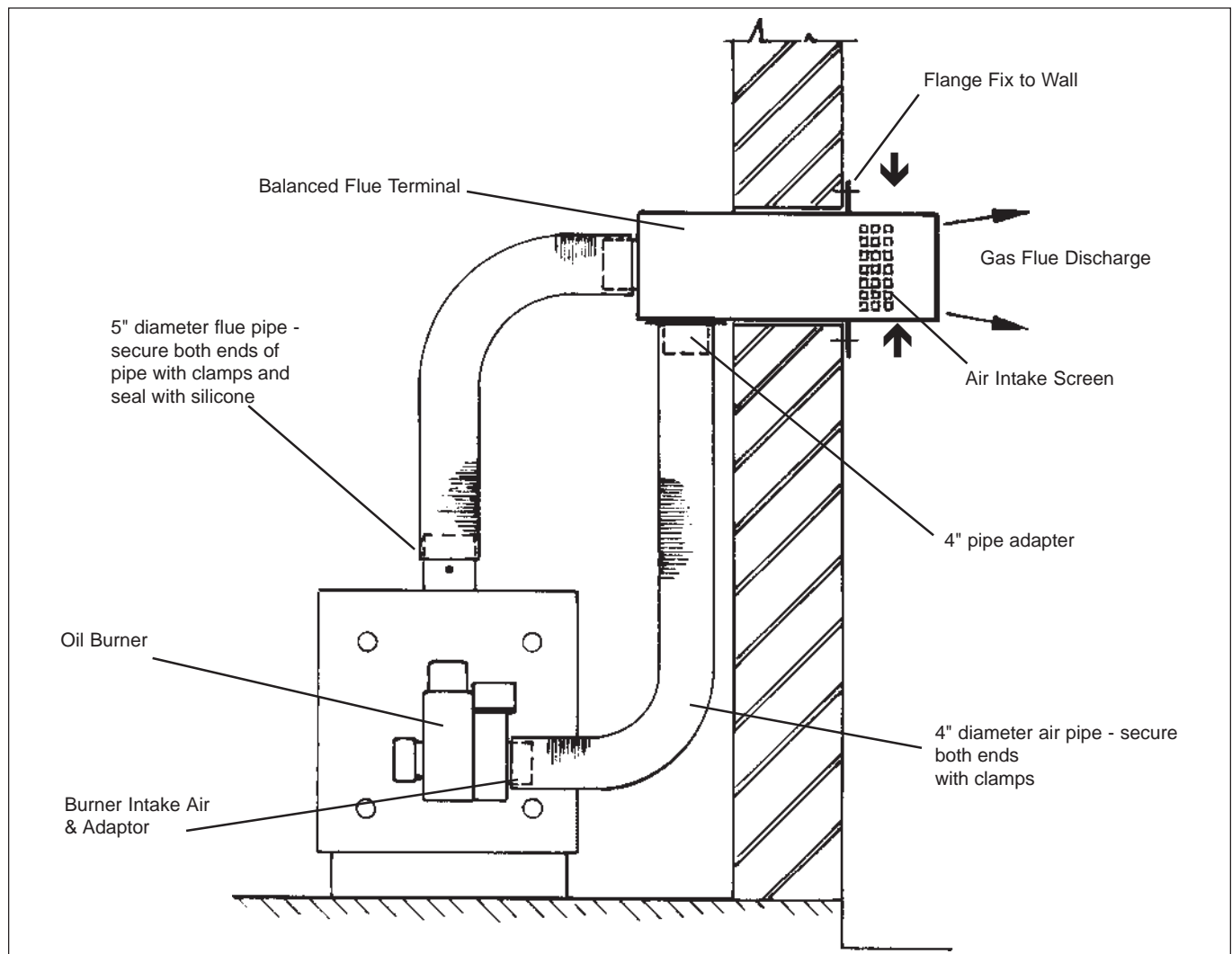

Figure 3. Direct Vent Balanced Flue System.

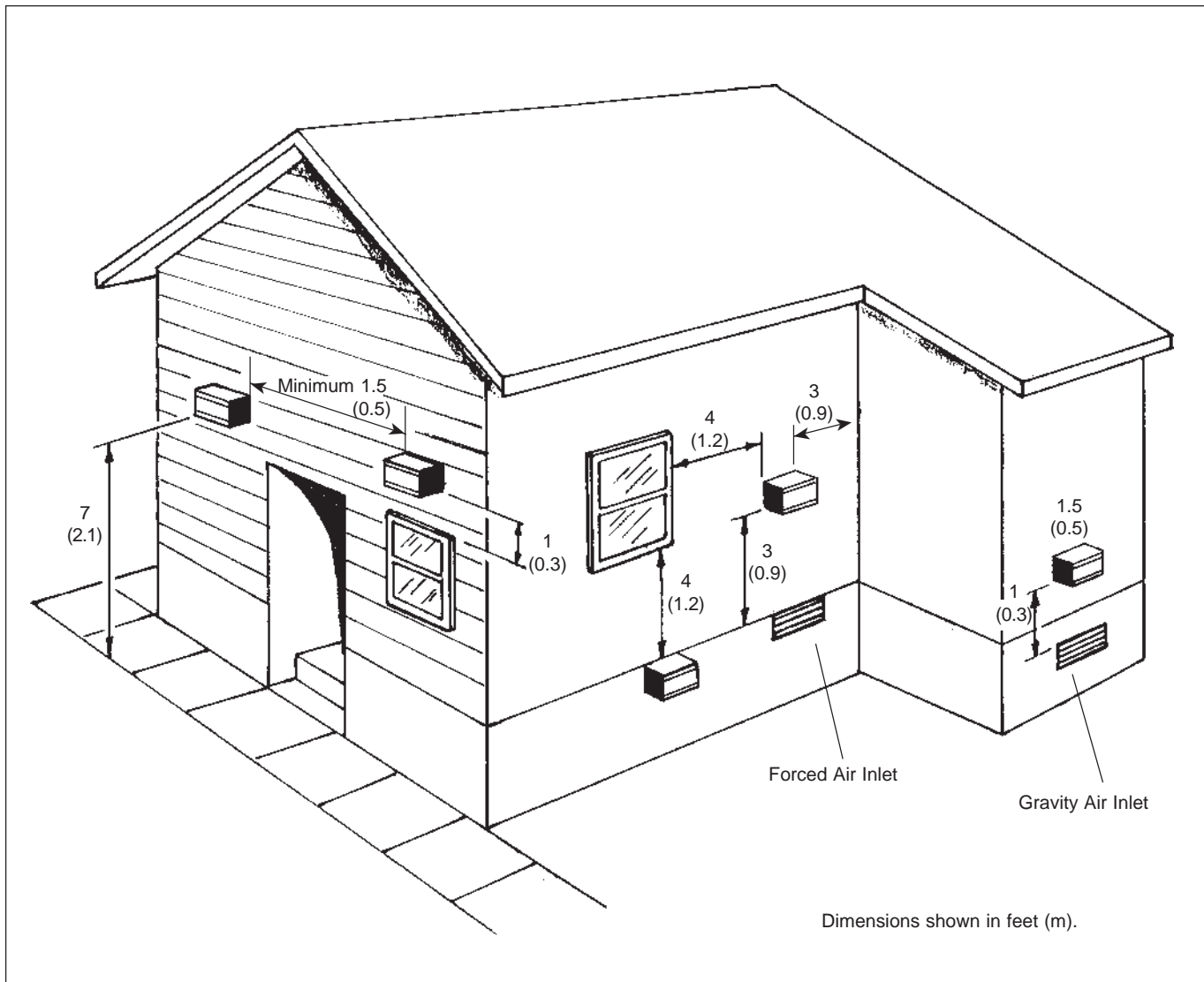

Figure 4. Terminal Locations - Minimum Distances.

Notes: (a) The “Univent” terminal is certified for use with zero clearance from combustible materials. The connection between the flue pipe and the balanced flue terminal must be provided with a 6" (152mm) clearance from combustibles or any reduced clearance acceptable to NFPA 31. P/N 70-330 (included with all direct vent kits) may be installed on the balanced flue terminal to reduce the required clearance to 2" in accordance with NFPA 31.

(b) The terminal is packed with insulation and is also air cooled thus making it suitable for installation through combustible walls.

4. Fit the 4 inch pipe adapter to the underside of terminal and connect the 4 inch flexible pipe between adapter and air intake ring on burner after first removing the black shroud. Cut the pipe to suit installation and securely fasten to burner and terminal with three fixing screws. Support pipe at regular intervals dependent upon length.

5. Finally, seal all around terminal on inside of wall with silicone sealant.

Note: “Univent” suitable for wall thickness up to 9" (229mm).

3K. Boiler Piping

The supply manifold (control center) provided with the boiler comes equipped with an air eliminator provided through an automatic float vent. This will provide system air elimination. Unit may be piped into a non diaphragm expansion tank utilizing this connection.

The pressure relief valve should be piped to a safe place of discharge.

The piping and related connections should follow good practice using approved joint sealants and conform with all state and local codes. When the boiler is connected to applications where standby temperatures may drop below 60°F (16°C) or to a

large volume of water (e.g. radiant floors) then an anti-condensing means must be provided. This may be accomplished utilizing a by-pass loop (see Figure 15) or optional thermostatic union (see Figure 16) P/N 2400-030.

Nontoxic heating system antifreeze may be added to the hydronic system provided that the concentration does not exceed 35% and the antifreeze contains an anti-foamant.

3L. Indirect Hot Water Tank

Install the tank in accordance with the manufacturers instructions using recommended pipe sizes, location of temperature / pressure relief valve and any other special requirement for correct installation.

A thermal expansion tank may be required on hot water tanks equipped with check valves or back flow preventors on the cold water supply.

3M. Burner Controls

The burner is fitted with a fully automatic control system which incorporates a cad cell to monitor the flame and shut down the burner in the event of flame failure. A push button is provided to restart the burner, but this must never be pressed more than once following a flame failure.

Pre-purge (direct vent only) provides an air supply prior to oil flow to ensure clean combustion under all conditions.

Post purge is also fitted to direct vent burners to completely clear all residual gases from the boiler and flue system. This is necessary with direct vent flues because of the lack of draft prevailing after the burner shuts down. The post purge time is factory set at 30 seconds.

3N. Fuel System (oil supply #2 fuel oil)

The oil supply should be run in heavy walled copper tubing, without any joints, using flared fittings only. It is important that the oil feed line to the burner is air tight otherwise firing problems could result.

3O. Gravity Head System

Where the fuel supply is level with or above the burner only a single pipe is required.

3P. Suction Lift System

Where the burner is above the fuel supply a return line must be provided in addition to the supply line. The arrangement requires the fitting of the bypass plug (provided) in the return port of the fuel unit. Air is automatically purged from the fuel unit and returned to the storage tank with this arrangement.

NOTE: If the suction lift exceeds 10 feet (3m), a two stage fuel unit should be used. For Riello burners obtain C700 kit for respective burners.

3Q. Oil Filter

An in-line oil filter should be fitted in the supply line and located inside the building between the tank shut-off valve and as near to the burner as possible. A shut-off valve should also be located close to the burner for ease of servicing.

3R. Wiring

Wiring connections between burner and aquastat on supply manifold should be made in accordance with wiring diagrams in this manual (see Figures 5 through 14). External wiring must be in accordance with local codes and regulations.

For convenience of servicing, a fuse disconnect switch should be fitted near the boiler. Field connections should be protected with a 15 amp fuse.

If an indirect hot water tank is used, the aquastat on tank should be wired so as to have preference over heating of the building. This requires the use of a Honeywell L6006A-1145 or equivalent aquastat on the tank working in conjunction with a zone valve or circulator relay. See wiring diagrams in this manual.

On boilers piped direct (no zones) set anticipator on thermostat to 0.8 amps.

SECTION 4. Operation

1. Check the boiler service switch is in the off position.
2. Check the boiler is filled with water and the complete system is purged of air.
3. Check the "cold fill" pressure is correct - usually 12 p.s.i.
4. Check there is ample oil in the storage tank and all manual shut-off valves in the fuel system are OPEN.
5. Set limit switch located in L8148A aquastat at 200° F (93°C).
6. Set manual reset limit switch at 220° F (104°C) (Direct Vent Boilers Only).
7. Carry out burner settings, see "Preliminary Burner Settings." (Table 3).
8. Push the safety reset button on burner control and release. Adjust room thermostat or tank aquastat to call for heat, switch ON boiler service switch and burner should start.

Caution

When using a direct vent system -

If smoke is seen coming from the vent terminal, switch off burner immediately. Otherwise the outside wall could be discolored. Check "Preliminary Burner Settings" again.

9. On one pipe systems the pump should be bled as soon as the burner motor starts. Bleed oil into a container for at least 15 seconds until it is seen to be free of air bubbles.

With two pipe suction systems, the air is returned to the oil storage tank where it is dissipated.

10. Adjust burner to achieve the reading shown under 4B “Burner Adjustments.”
11. If burner fails to start, check “Trouble Shooting Guide”; Table 4.

4A. Preliminary Burner Settings

- Fit the nozzle to suit firing rate required
- Set air dial to the appropriate setting
- Fit correct number stop pin or positioning bar to burner.
- Fit a pressure gauge to the fuel pump.

4B. Burner Adjustments

Test equipment required:

CO₂ analyzer
Draft gauge
Fuel pressure gauge
Stack thermometer
Smoke tester

Test readings should be taken from the plug in the flue collar. *Over the fire sampling is not necessary on pressure fired boilers.*

NOTE: Do not drill into the flexible vent pipe.

After firing the burner for about 5 minutes, make the following checks and adjustments:

- Check the pump pressure and if necessary adjust pressure to obtain 140 / 150 p.s.i.
- Gradually close air dial until a slight smoke trace is measured, then take a flue gas sample and check CO₂ reading which should be about 13%.
- Open air dial to reduce CO₂ by ½%, then lock dial in this position.

NOTE: The slight increase in excess air provides a built in margin to ensure clean combustion throughout the heating season.

- (4) The vent pressure of the D-MAX will vary dependent upon length of vent pipe used and the firing rate chosen.

If pressure exceeds 0.13" W.C. recheck burner setup for excess air / low CO₂ reading.

NOTE: With conventional chimneys the pressure loss will be less because of the higher draft normally generated.

Firing Rate GPH/Boiler	Burner	Nozzle Size*	Air Dial Setting	Head Positioning
0.75 MAX	Beckett AF2	0.65 / 70°AS	2.50	Pin # 1
	Carlin EZ1	0.65 / 60°B	0.6	0.75
	Riello R35.3	0.65 / 60°B	2.5	1.00
	Riello F3	0.65 / 60°B	3.00	1.00
0.75 D-MAX	Beckett AF2	0.65 / 70°AS	2.50	Pin # 1
	Carlin EZ1	0.65 / 60°B	0.6	0.75
	Riello BF5	0.65 / 60°B	3.5	1.00
1.00 MAX	Beckett AF2	0.85 / 60°AS	3.25	Pin # 4
	Carlin EZ1	0.85 / 60°B	0.6	0.85 / 1.0
	Riello R35.3	0.85 / 60°B	3.00	2.00
	Riello F5	0.85 / 60°B	3.20	2.00
1.00 D-MAX	Beckett AF2	0.85 / 60°AS	3.50	Pin # 4
	Carlin EZ1	0.85 / 60°B	0.85	0.85 / 1.0
	Riello BF5	0.85 / 60°B	4.00	1.50
1.20 MAX	Beckett AF2	1.00 / 60°AS	4.00	Pin # 6
	Carlin EZ1	1.00 / 60°B	0.75	0.85 / 1.0
	Riello R35.3	1.00 / 60°B	3.50	3.00
	F5	1.00 / 60°B	3.60	3.00
1.20 D-MAX	Beckett AF2	1.00 / 60°AS	4.50	Pin # 6
	Carlin EZ1	1.00 / 60°B	1.00	0.85 / 1.0
	Riello BF5	1.00 / 60°B	4.50	2.00
1.40 MAX	Carlin EZ1	1.25 / 60°B	0.90	1.10 / 1.25
	Riello F10	1.25 / 60°B	2.60	1.50
1.40 / D-MAX	Carlin EZ1	1.25 / 60°B	1.50	1.10 / 1.25
1.65 MAX	Carlin EZ1	1.35 / 60°B	1.10	1.35 / 1.50
	Riello F10	1.35 / 60°B	3.20	2.00
1.65 / D-MAX	Carlin EZ1	1.35 / 60°B	1.65	1.35 / 1.50

* Beckett AF2 uses Danfos nozzle. Carlin and Riello use Delevan.

Table 3. Preliminary Burner Settings.

5. Flue gas temperature will vary according to the firing rate. The following typical net temperatures should be obtained after approximately 15 minutes of burner operation. Note that the temperatures listed are net temperatures. The net temperature listed should be compared to the measured (actual) temperature minus the temperature of the

combustion air. (i.e. use the outside temperature when the combustion air is ducted, and use the room temperature when room air is used for combustion:

- 320°F @ 0.75 GPH (160°C @ .75mL/s)
- 350°F @ 1.00 GPH (177°C @ 1mL/s)
- 420°F @ 1.20 GPH (216°C @ 1.20mL/s)
- 330°F @ 1.40 GPH (166°C @ 1.40mL/s)
- 410°F @ 1.65 GPH (210°C @ 1.65mL/s)

4C. Sequence of Operation

When the room thermostat or hot water tank aquastat calls for heat the burner and circulating pump start. The burner and pump continue to run until the

heat demand is satisfied - the hot water tank being satisfied before the room heating requirements.

If the boiler water reaches the high limit setting of 200° F (93°C) the burner will shut off but the pump will continue to operate to clear the residual heat. When the boiler temperature falls the burner will restart if there is still a demand for heat.

A manual reset high limit aquastat (set at 220° F) (104°C) is provided on Direct Vent Boilers to shut off the burner in the event of a failure of the high limit control.

The burner features a post purge timer on Direct Vent Boilers which provides a timed overrun of the fan to clear residual flue gases from the boiler and flue system after combustion is shut off.

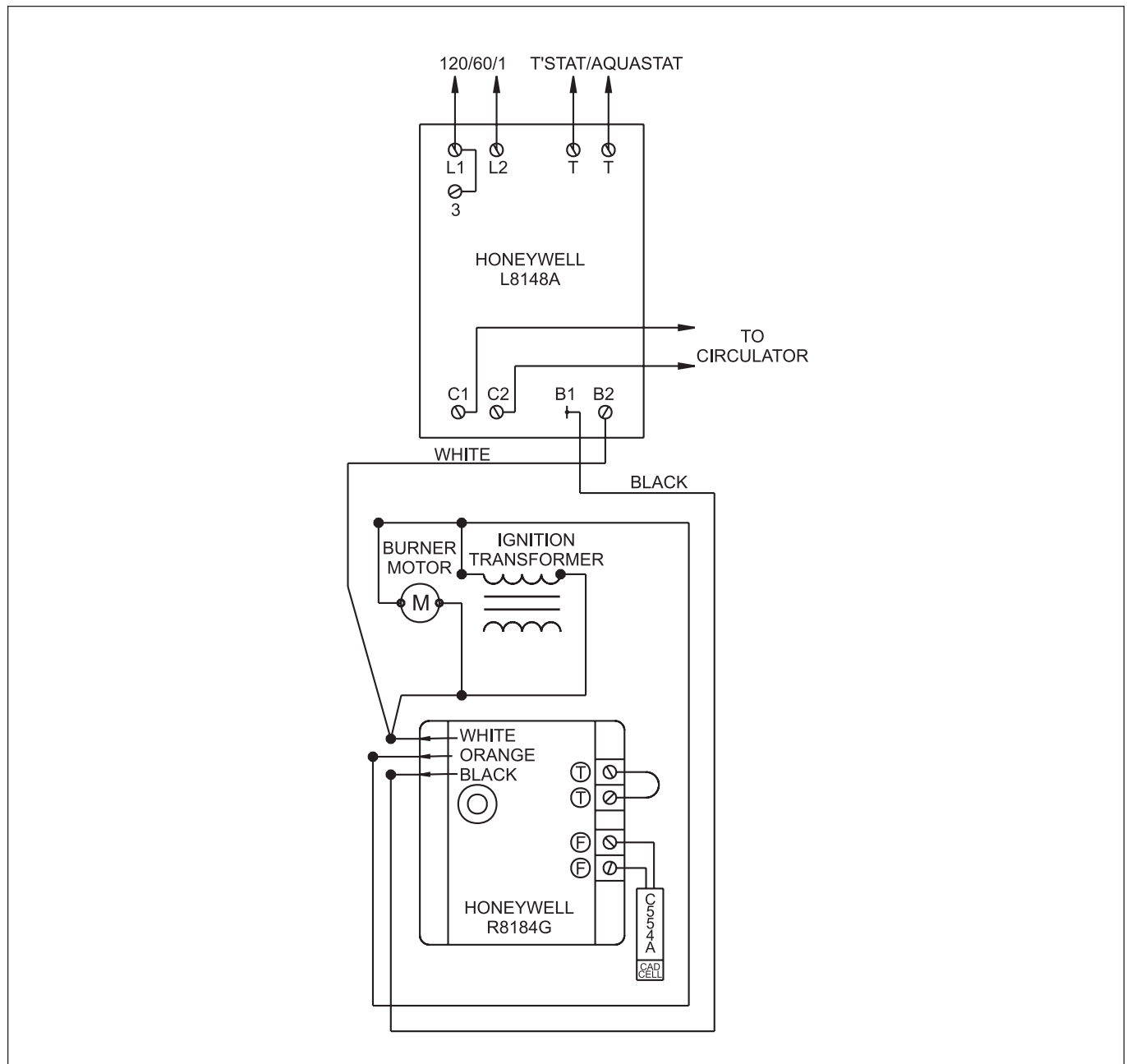

Figure 5. Internal Wiring with Beckett AF II (chimney vent).

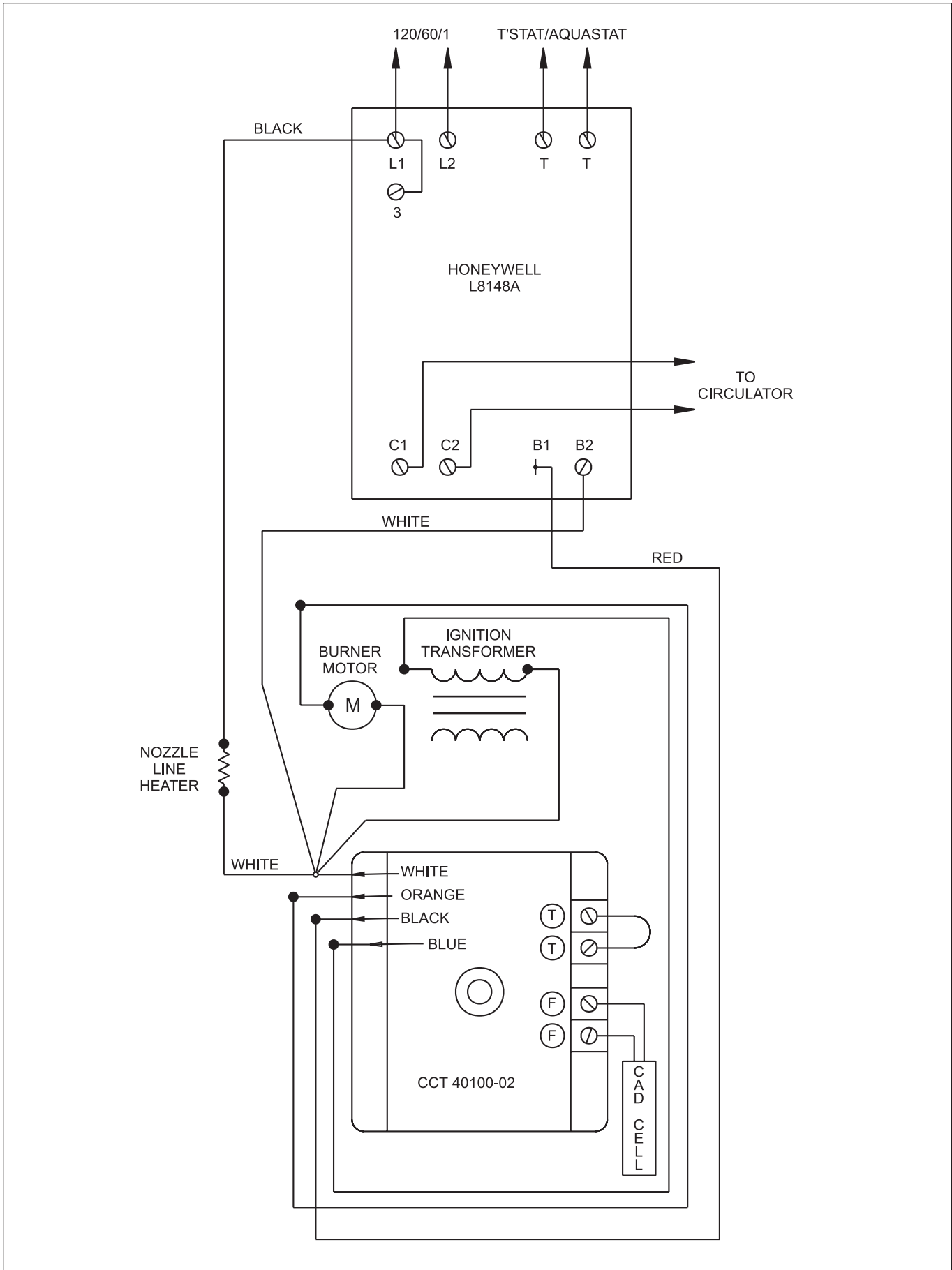

Figure 6. Internal Wiring with Carlin EZ-1 (chimney vent).

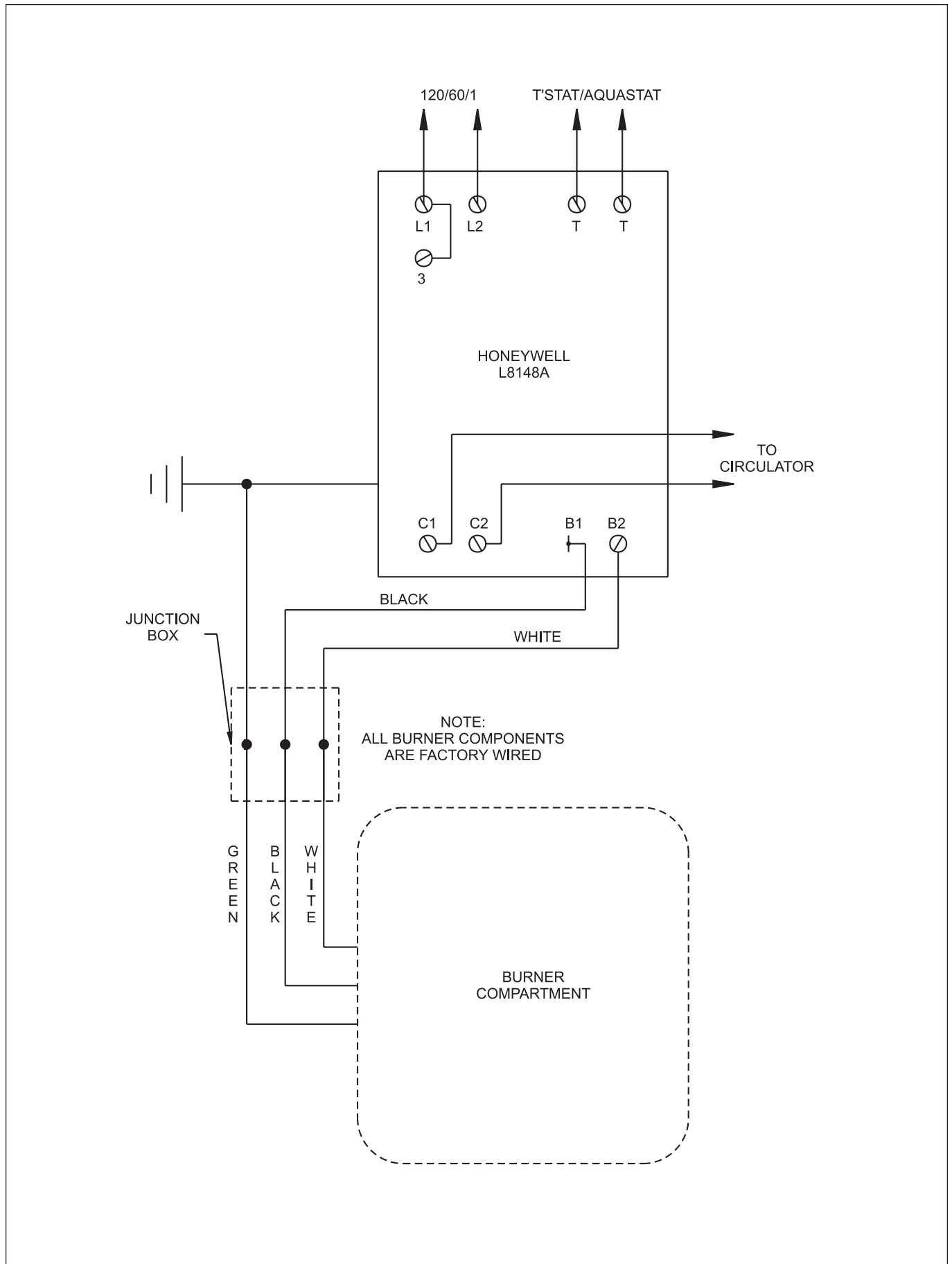

Figure 7. Internal Wiring with Riello R35, F5 and F10 (chimney vent).

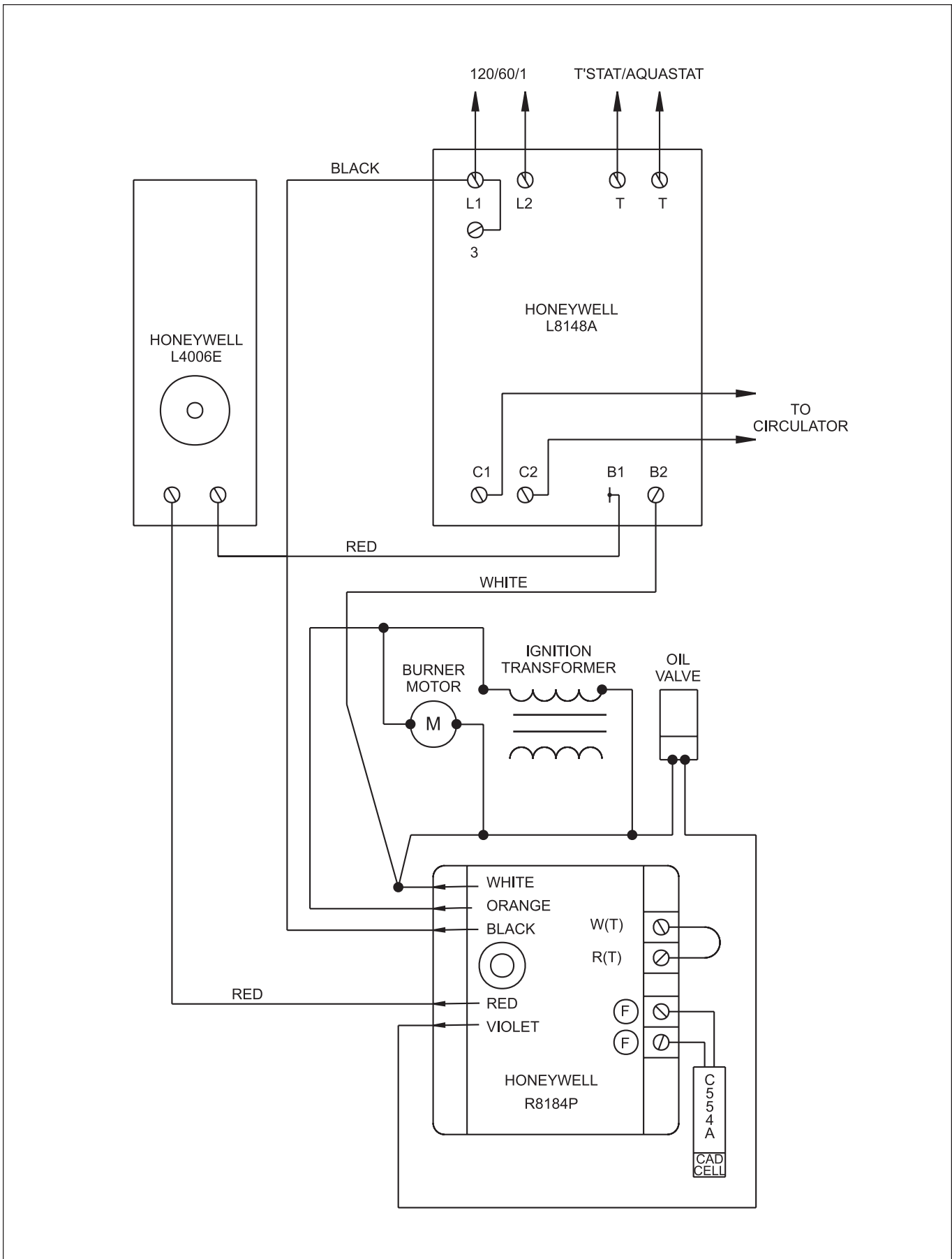

Figure 8. Wiring Diagram for "D-MAX" Direct Vent Boiler. Internal Wiring with Beckett AF II with Honeywell R8184P Control.

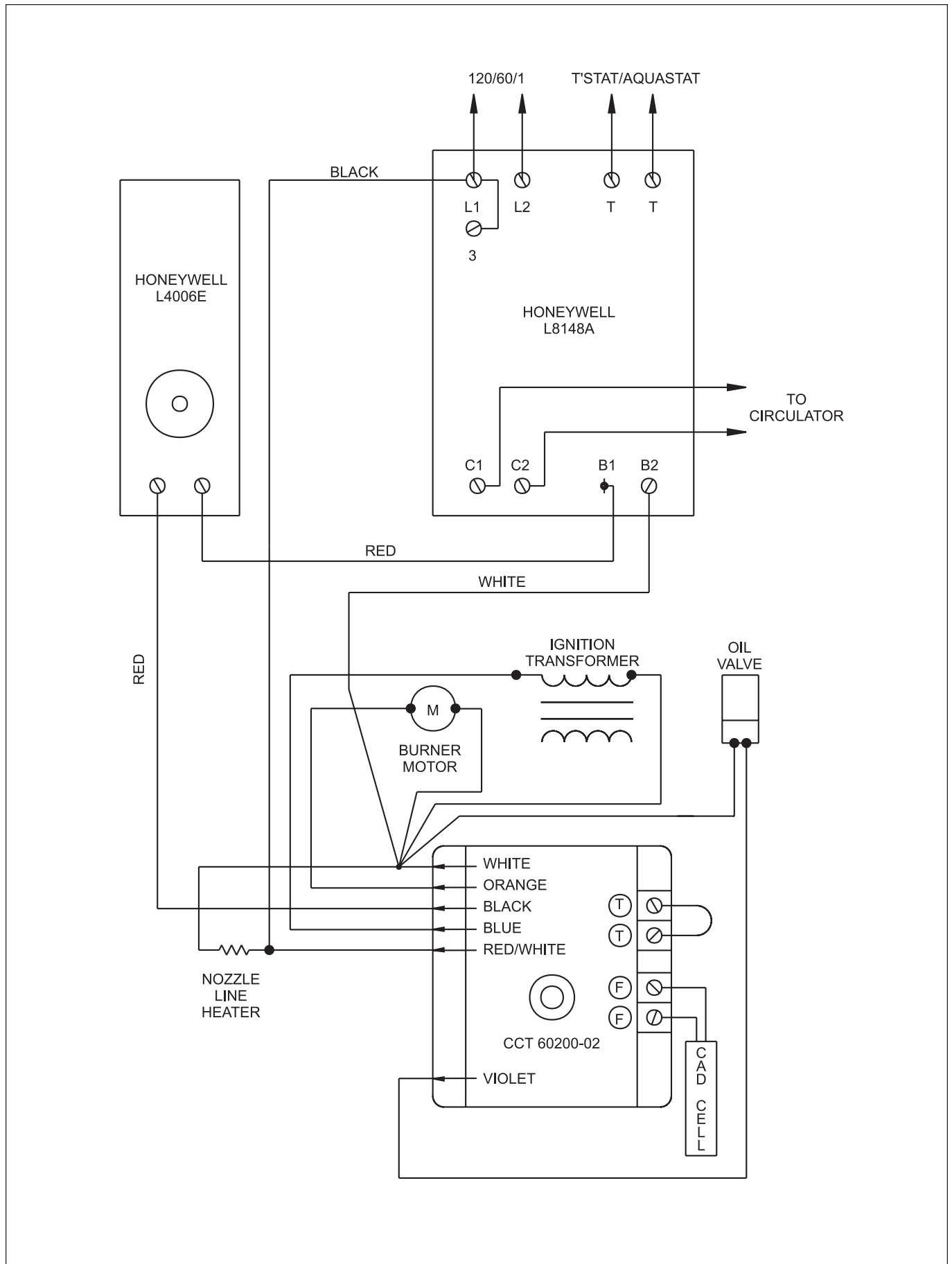

Figure 9. Internal Wiring with Carlin EZ-1 (direct vent).

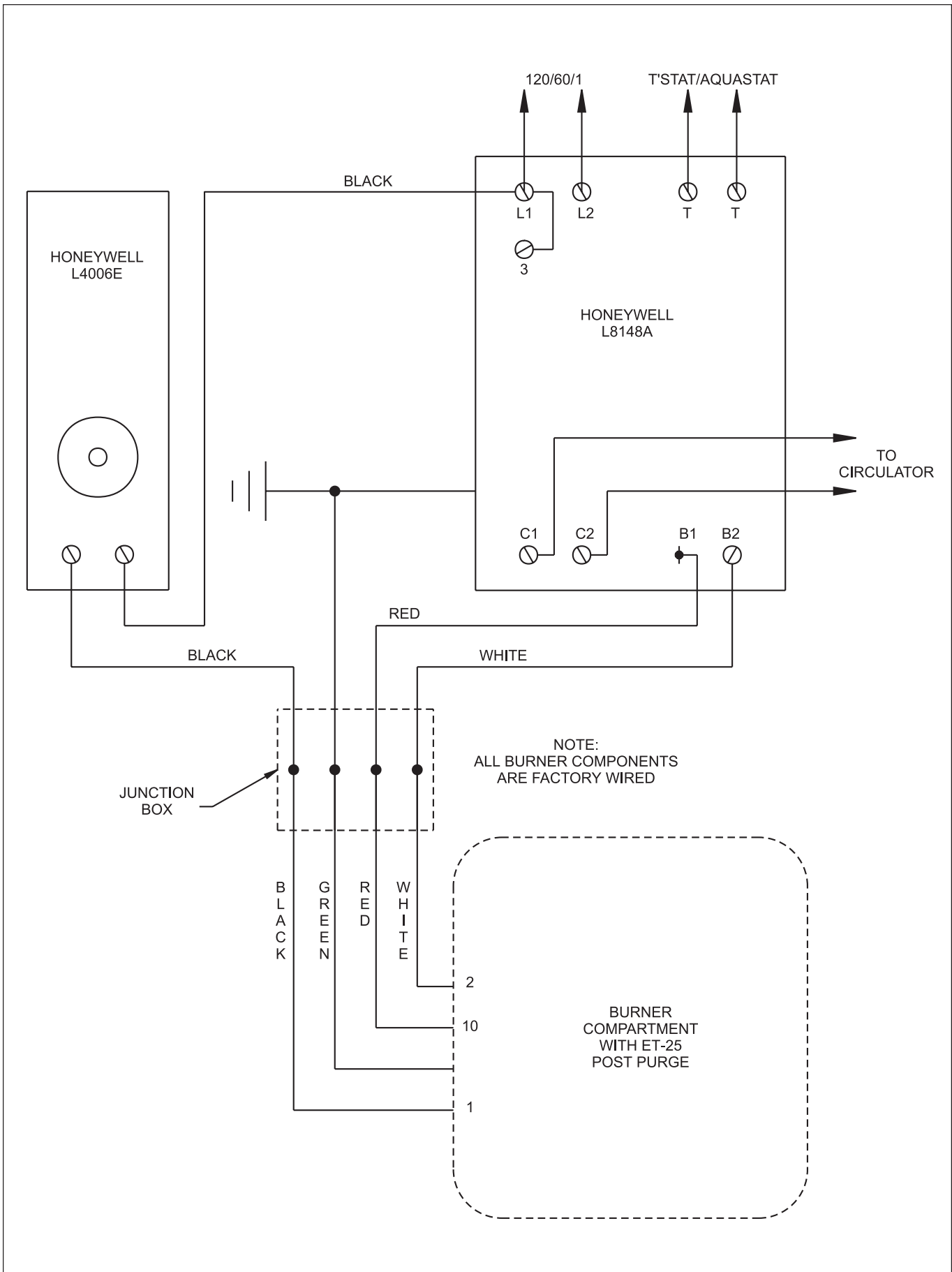

Figure 10. Internal Wiring with Riello BF5 (direct vent).

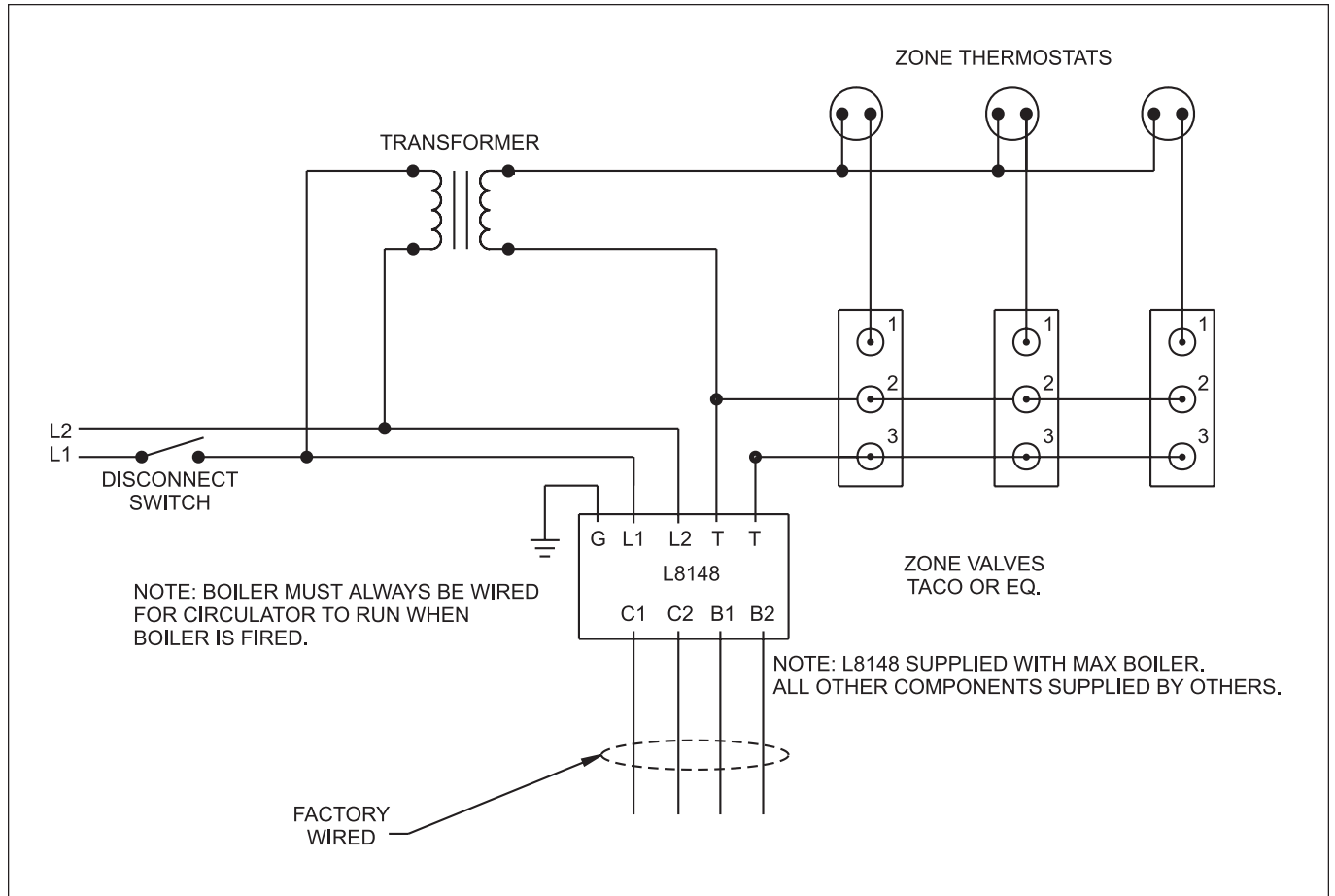

Figure 11. Wiring Diagram. Boiler Only. Zoning with Zone Valves.

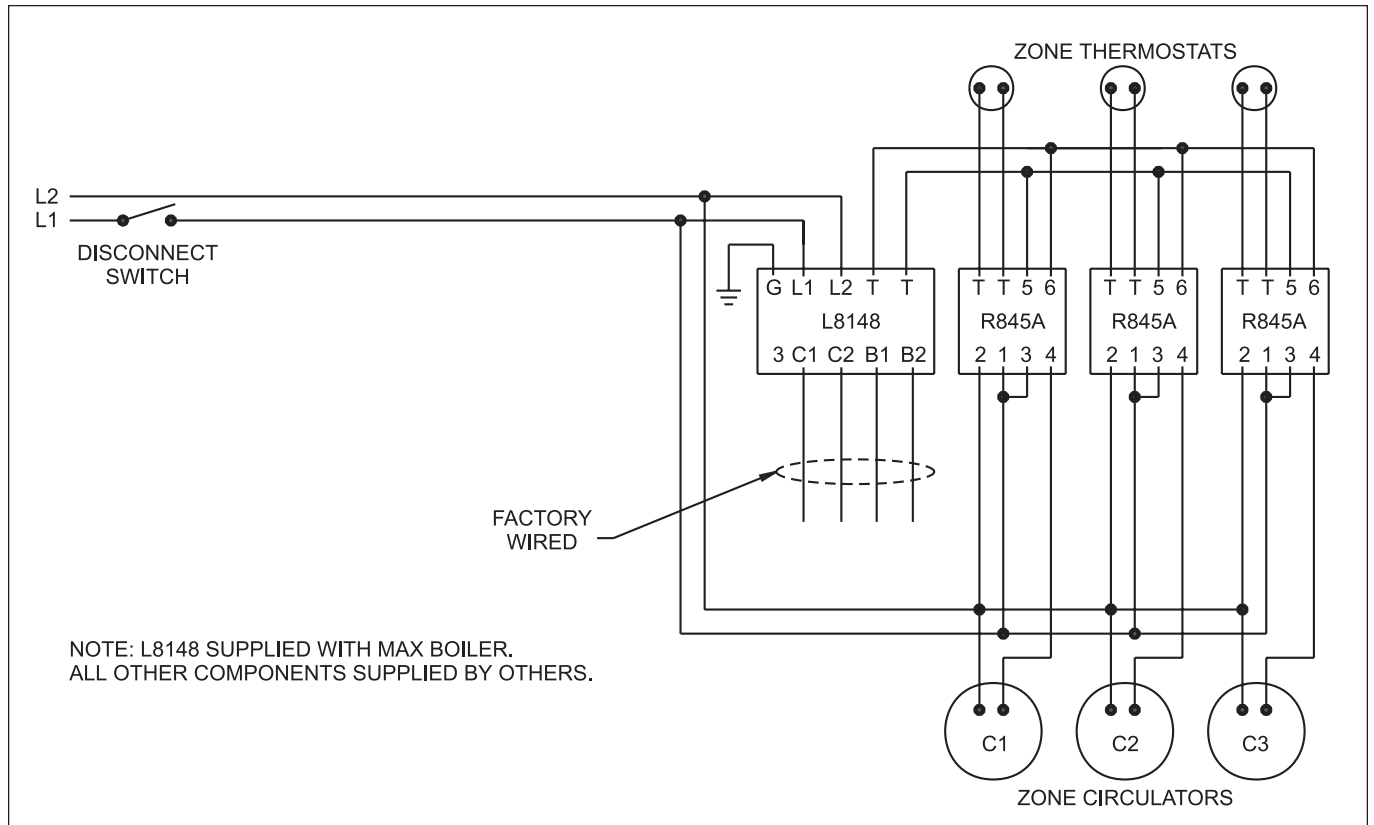

Figure 12. Wiring Diagram. Boiler Only. Zoning with Circulators.

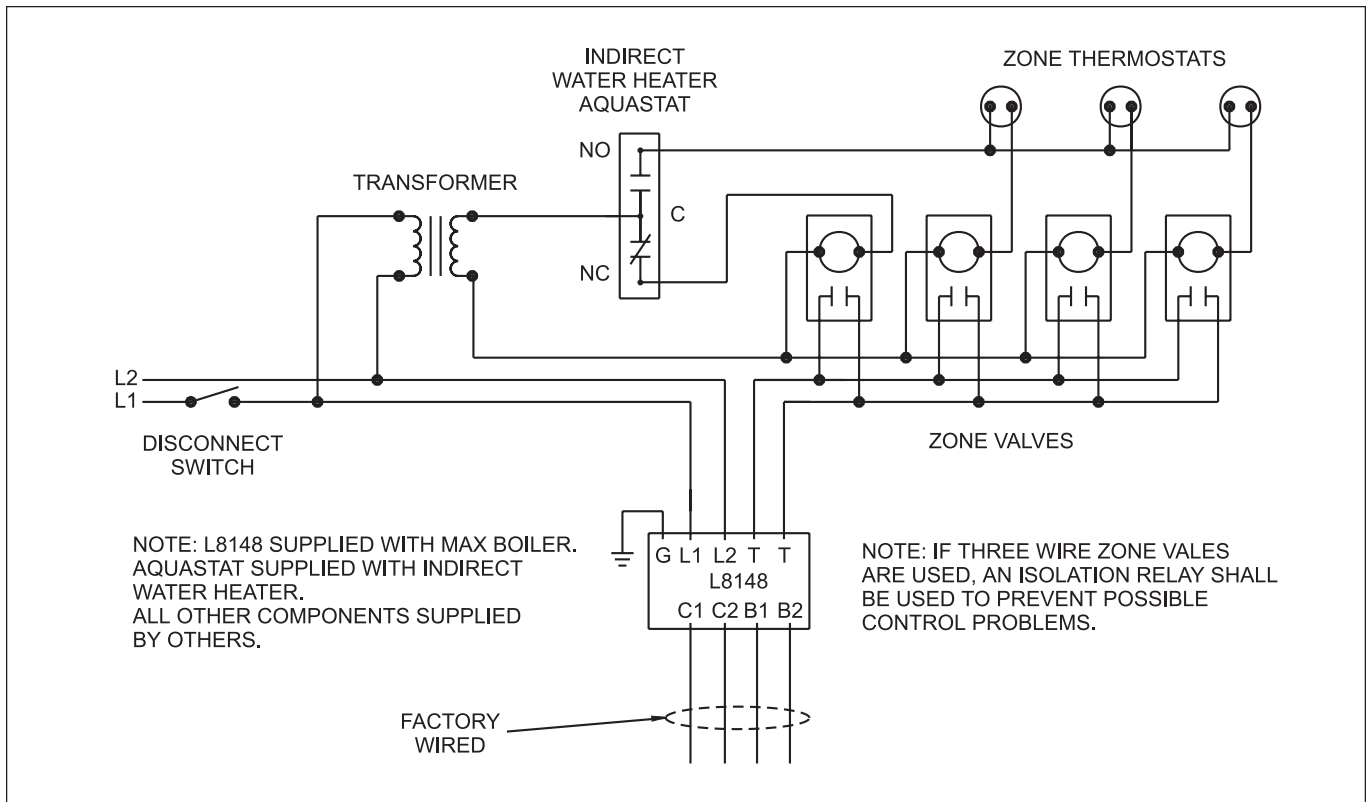

Figure 13. Wiring Diagram. Boiler with Indirect Water Heater. Zoning with Zone Valves.

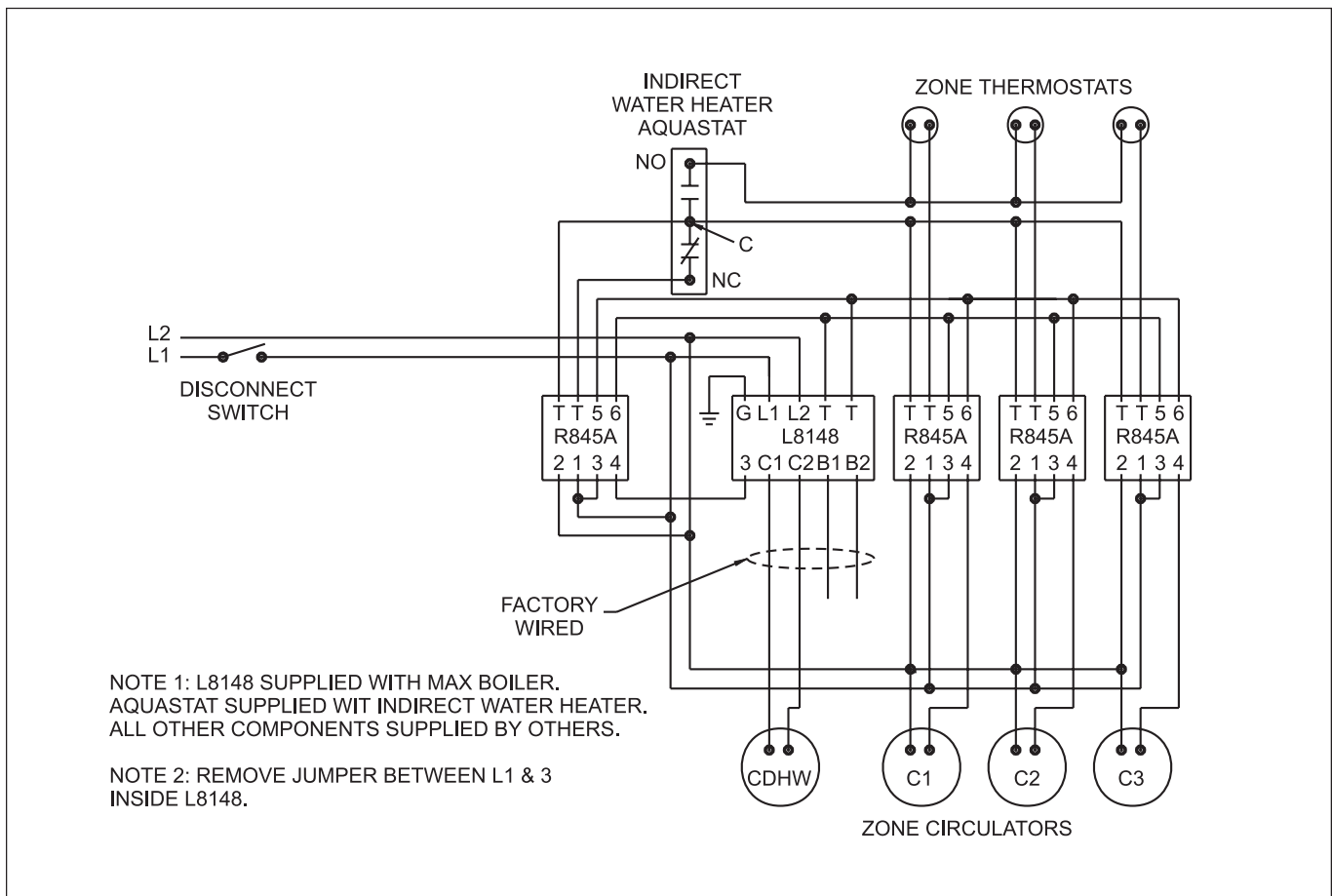

Figure 14. Wiring Diagram. Boiler with Indirect Water Heater. Zoning with Circulators.

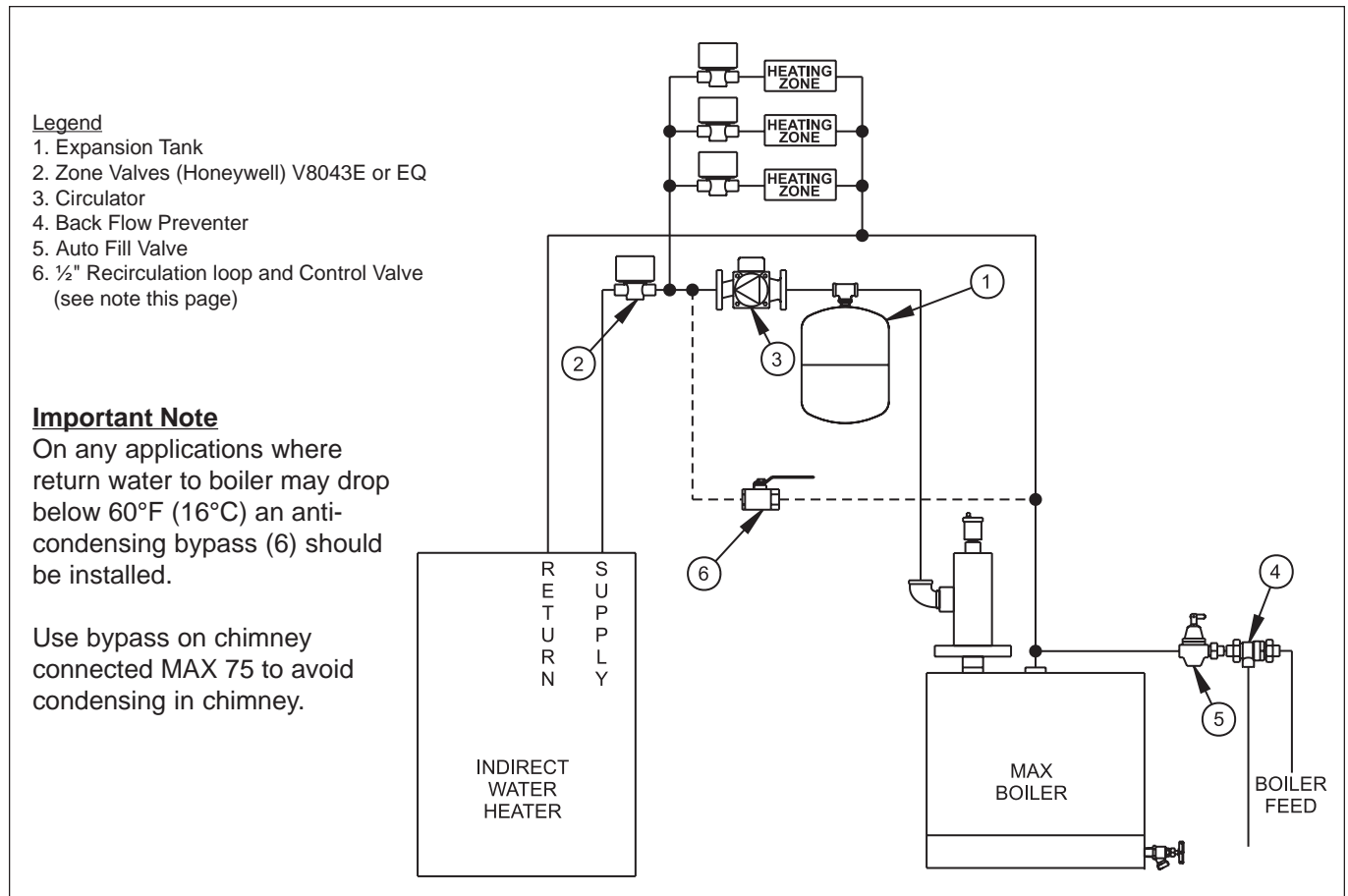

Figure 15. Piping Diagram. “MAX” Boiler with Indirect Water Heater. Zoning with Zone Valves.

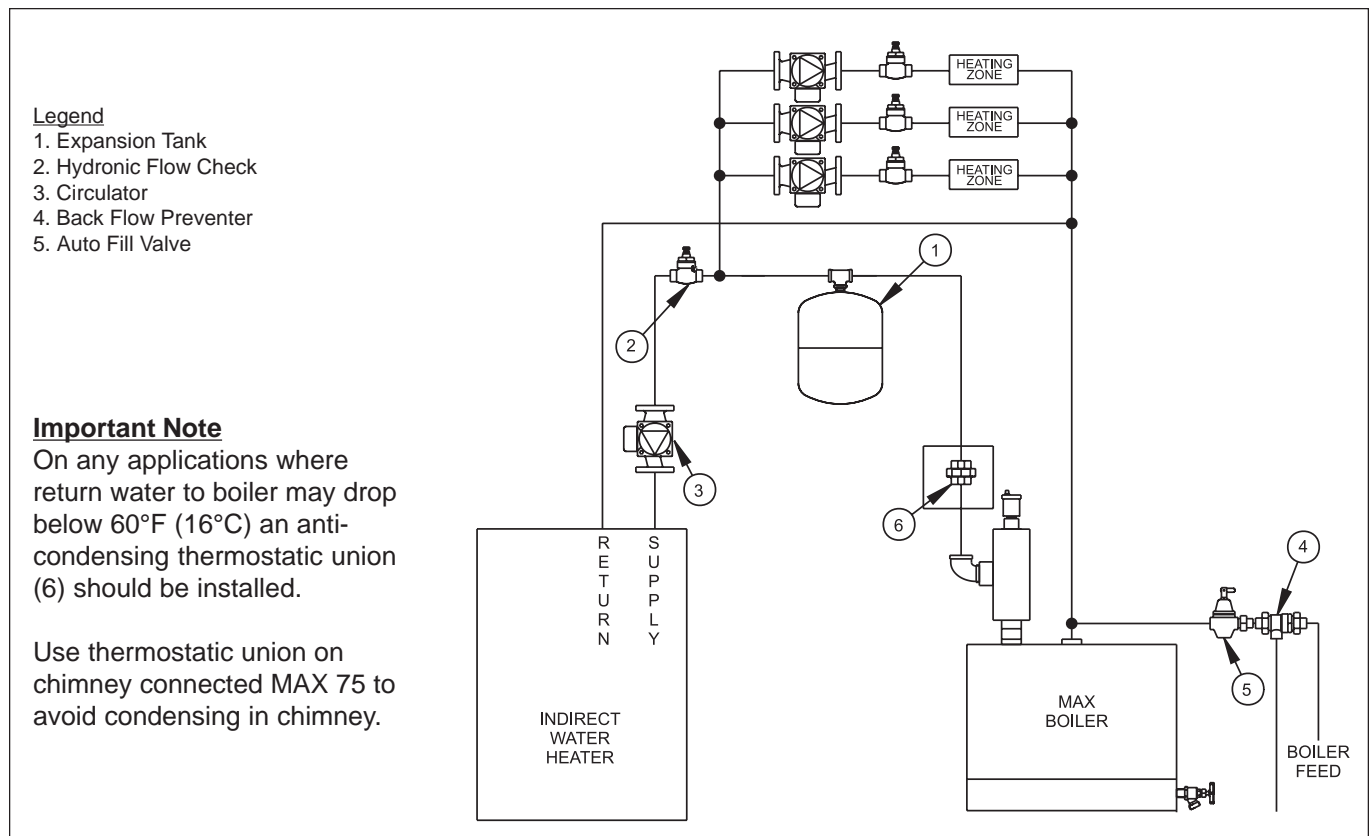

Figure 16. Piping Diagram. “MAX” Boiler with Indirect Water Heater. Zoning with Circulators.

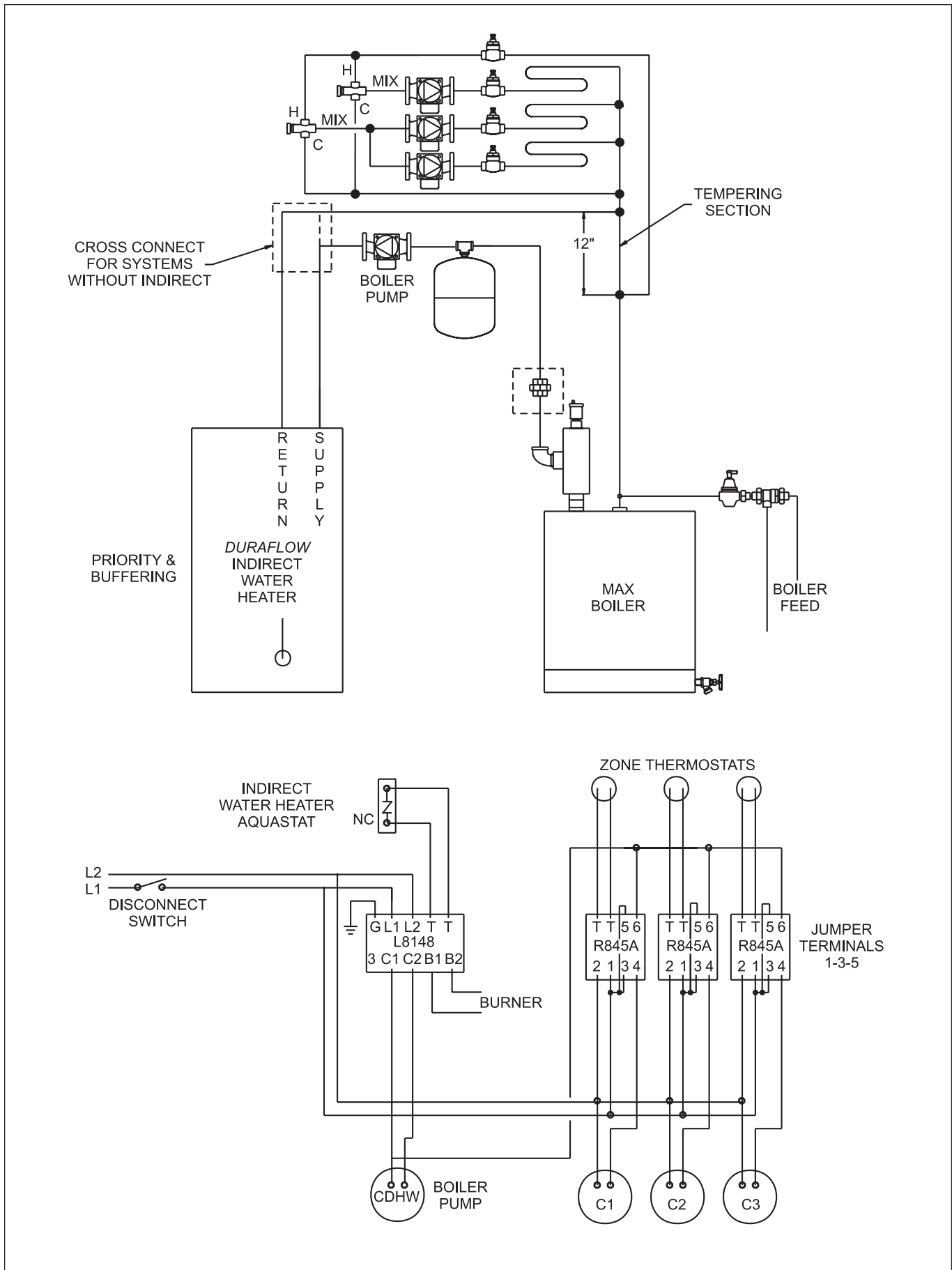

Figure 17. Piping the MAX in a Radiant Application.

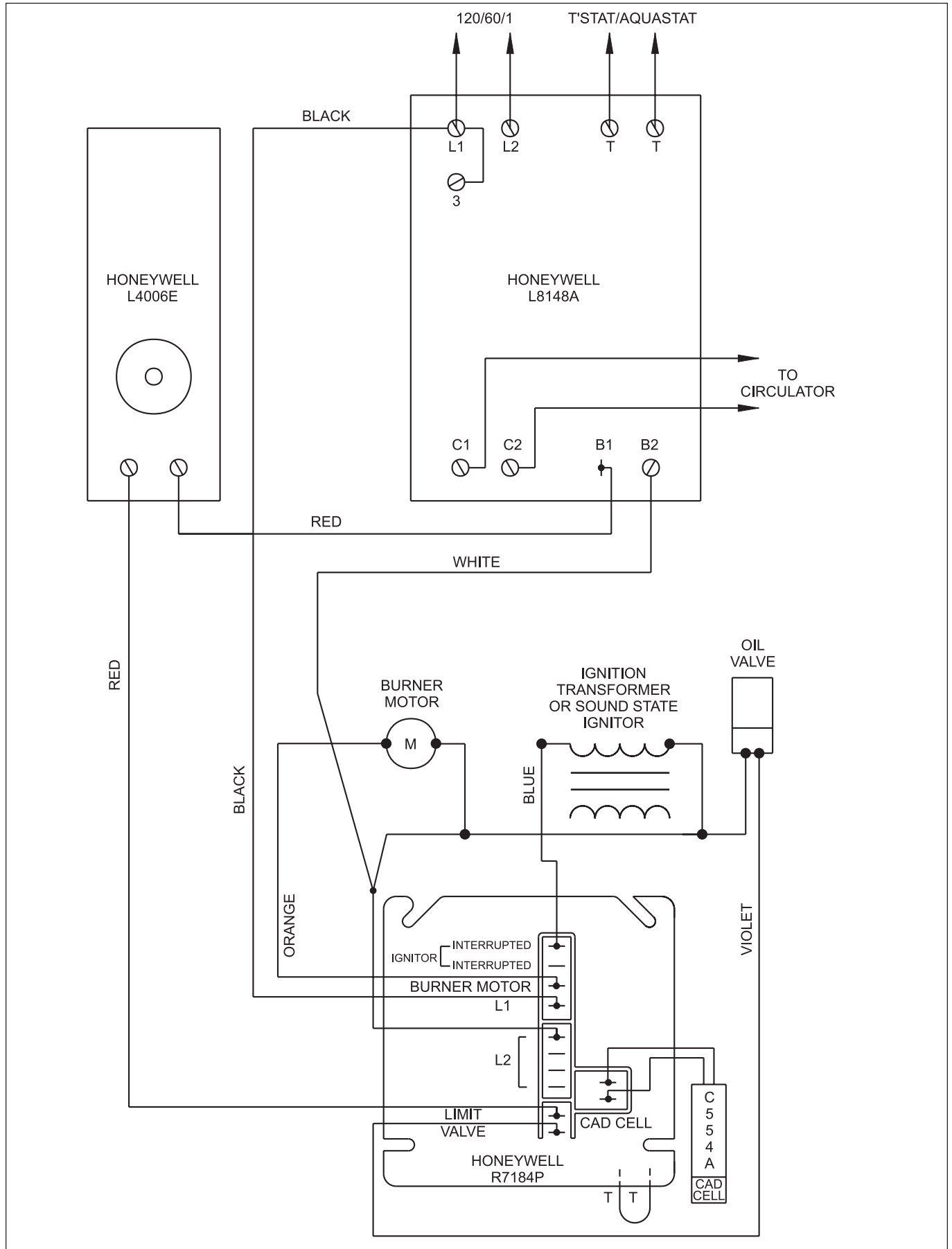

Figure 18. Wiring Diagram for DMAX Direct Vent Boiler. Internal Wiring with Beckett AF II with Honeywell R7184P Control.

SECTION 5. Maintenance

To maintain the boilers high thermal efficiency and reliable operation, it should be serviced and the vent system inspected every year by a qualified service person.

The service should preferably be carried out directly after the heating season so as to avoid any unnecessary corrosion.

5A. Boiler

The boiler flue ways may be cleaned by swinging open front door after disconnecting flexible air pipe and oil line from burner.

Remove the baffles from the flue gas annulus, brush out scale deposits with a flexible brush and remove with a vacuum cleaner. The rear door can also be taken off if required to gain access for a complete inspection of the internal flue ways. When replacing doors ensure that they are fully tightened to make a gas tight seal.

5B. Oil Burners

Clean combustion head assembly and all air handling parts. Inspect condition of nozzle and replace if necessary with a nozzle of the same make and specification.

Check the electrode settings are in accordance with the oil burner instructions. Also ensure the high voltage leads are firmly secured to the ignition electrodes. Clean all deposits from blower wheel blades. Clean screen in fuel pump.

5C. Oil Filter

Replace the oil filter cartridge with one of the same specifications.

SECTION 6. Homeowner Information

WARNING

Never use gasoline, waste oil or garbage in your boiler.
Never try to ignite oil by tossing burning paper or other material into your boiler.
Never leave combustible materials around your boiler.
Never tamper with the boiler controls or burner settings.

6A. General

1. To avoid unnecessary expense and inconvenience, your boiler should be serviced at least once a year by a qualified service person.
2. Always keep the fuel tank full, especially in summer to prevent moisture condensing on the inside surface of the tank.
3. The oil burner motor is permanently lubricated - no oiling is necessary.
4. Keep a regular check on the direct vent terminal for any blockage by leaves or other debris. Your boiler relies on an adequate supply of air for clean combustion and any obstruction of the air inlet could result in poor combustion and fuel odors.
5. If you experience problems with your boiler check the following points before calling the service person:
 - a. Check that there is fuel in the tank.
 - b. Check the room thermostat is set high enough.
 - c. Check the service switch near the boiler is in the ON position.
 - d. Check that the burner control reset button, if open (popped) reset by pushing button in. If burner does not complete a proper start and heat sequence **DO NOT RESET SWITCH A SECOND TIME** until a qualified service person has inspected the burner.
 - e. On direct vent model, check that the manual reset control has not opened (popped). Do not reset more than one time without having the boiler inspected by a qualified service person.

FAULT	POSSIBLE CAUSE	ACTION
BURNER DOES NOT START	Primary safety control tripped	Press reset button on control Note: ONLY PRESS ONCE
	High limit thermostat tripped	Press reset button
	Thermostat satisfied	Turn thermostat to a higher setting
	Fuse blown or breaker tripped	Fit new fuse or reset breaker. If it blows again check for short circuit.
	Check voltage at burner between orange and white wires	If voltage confirmed replace primary control. If no voltage check t-stat and wiring connects
	Motor or fuel pump seized	Turn off power to burner and rotate by hand. Replace if necessary
	Cad. cell dirty or faulty	Clean face or replace cell
BURNER RUNS BUT FLAME NOT ESTABLISHED	No oil supply	Check oil level in tank and oil supply to burner
	Water in oil tank	Drain water from tank and bleed line to burner
	Nozzle plugged	Replace with nozzle specified in manual
	Ignition transformer faulty	Check quality of spark and replace transformer if necessary
	Electrodes carboned or shorting	Clean electrode and check settings
	Cracked porcelain insulator	Replace electrodes
	Faulty oil valve	Replace valve
	Too much combustion air	Reduce air setting to obtain 11 to 12% CO ₂
	Low oil pressure	Check pump pressure and adjust to 140 psi
FLAME ESTABLISHED THEN BURNER LOCKS OUT	Water in oil tank	Drain water from tank and bleed line to burner
	Oil filter or pump strainer plugged	Replace filter cartridge and clean strainer
	Too much or too little combustion air	Adjust air control to obtain 11 to 12% CO ₂
	Air trapped in fuel pump	Bleed off air from pressure gauge port
	Low oil pressure	Check pump pressure and adjust to 140 psi
BURNER PULSATES	Lack of combustion air	Check terminal for block at air intake screens
	Terminal fouled with debris at flue gas outlet	Remove end cap and clean outlet
	Incorrect air setting	Adjust air control to obtain 11 to 12% CO ₂
	Air leakage into fuel system	Bleed pump and seal air leaks
	Water in oil tank	Drain water from tank oil at burner
	Incorrect pump pressure	Check oil pressure and adjust to 140 psi
	Pump coupling worn or broken	Repape coupling
	Nozzle partially plugged	Replace with nozzle specified in manual
	Boiler flue ways fouled	Brush out all flue deposits

Table 4. Troubleshooting.

SECTION 7. Part Numbers

Part Number	Description
70-274	D-MAX Control Center (boxed)
72-274	MAX Control Center (boxed)
70-160	Control Center (manifold only)
70-184	Beckett AF2 (for direct vent D-MAX)
72-184	Beckett AF2 (for chimney vent MAX only)
70-185	Carlin EZ-1 Elite Burner (for direct vent D-MAX)
72-185	Carlin EZ-1 Elite Burner (for chimney vent MAX only)
70-552	Riello BF-5 (for direct vent D-MAX)
70-212	Z-Flex, stainless steel, 5" x 10'
70-214	Z-Flex, aluminum, 4" x 10'
70-202	Z-Flex, stainless steel, 5" x 15'
70-204	Z-Flex, aluminum, steel, 4" x 15'



ETL Approval for
D-MAX boilers only



LAARS
HEATING SYSTEMS

Waterpik Technologies, Inc.
6000 Condor Drive, Moorpark, CA 93021 • 805.529.2000 • FAX 805.529.5934
20 Industrial Way, Rochester, NH 03867 • 603.335.6300 • FAX 603.335.3355
480 S. Service Road West, Oakville, Ontario, Canada L6K 2H4 • 905.844.8233 • FAX 905.844.2635
www.laars.com

Litho in U.S.A. © Laars Heating Systems 0011 Document 1106B