

Installation, Operation and Maintenance Instructions for **9600 HWG**

Condensing Water
Heater for Natural Gas
or Propane

Models **HWG-M2-150**
 HWG-M2-175
 HWG-M2-200
 HWG-M2-250

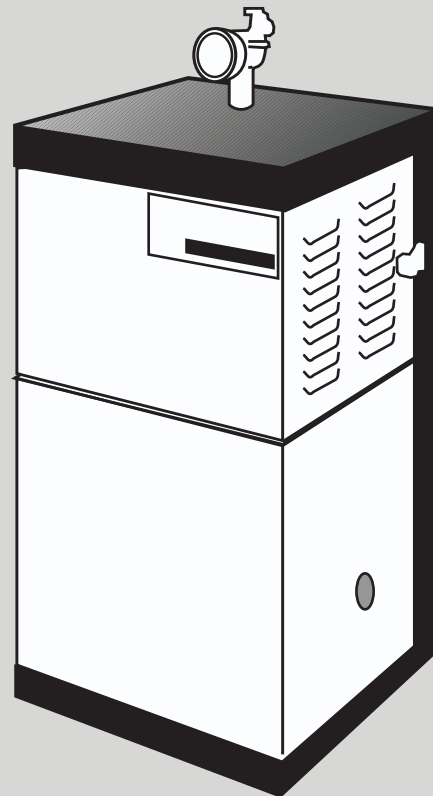

FOR YOUR SAFETY: This product must be installed and serviced by a professional service technician, qualified in hot water heater installation and maintenance. Improper installation and/or operation could create carbon monoxide gas in flue gases which could cause serious injury, property damage, or death. Improper installation and/or operation will void the warranty.

⚠ WARNING

If the information in this manual is not followed exactly, a fire or explosion may result causing property damage, personal injury or loss of life.

Do not store or use gasoline or other flammable vapors and liquids in the vicinity of this or any other appliance.

WHAT TO DO IF YOU SMELL GAS

- **Do not try to light any appliance.**
- **Do not touch any electrical switch; do not use any phone in your building.**
- **Immediately call your gas supplier from a neighbor's phone. Follow the gas supplier's instructions.**
- **If you cannot reach your gas supplier, call the fire department .**
- **Installation and service must be performed by a qualified installer, service agency or the gas supplier.**



TABLE OF CONTENTS

SECTION 1.

Introduction and Unpacking

1A.	Special Installation Considerations	3
1B.	Checklist of Materials Installer Must Provide	3
1C.	Unpacking	3

SECTION 2.

Locating and Clearances

2A.	Locating the 9600 HWG	4
2B.	Locating the Unit for Proper Venting Distance from the Outside Wall or Roof Termination	4
2C.	Locating Vent Openings on Outside Wall	5
2D.	Locating Unit for Proper Vent Height	5
2E.	Locating Unit with Respect to Ventilation	5
2F.	Locating Unit with Respect to Storage Tanks	5

SECTION 3.

Installation

3A.	Installing Vent Piping Terminal	5
3B.	Connecting Gas to the 9600 HWG Water Heater	6
3C.	Connecting Water System Piping, Fittings & Accessories	6
3D.	Tank Temperature Control	7
3E.	Condensate Drain Connection	7
3F.	Electrical Connections	7
3G.	Main Power	7
3H.	Temperature Control	7

SECTION 4.

Start Up

4A.	Filling the System	10
4B.	Operation Checklist	10

SECTION 5.

Maintenance

5A.	Owner Care and Maintenance	11
5B.	Routine De-Liming Procedure	11
5C.	Thermostat Replacement	11
5D.	Vent and Condensate Drain Inspection (performed annually)	11
5E.	Cleaning Combustion Chamber Coil and/or Burner	12
5F.	Combined Water (potable) Heating and Space Heating	12

SECTION 6.

Quick Reference Trouble Shooter

6A.	Short Cycling	13
6B.	9600 Overheats Quickly or Knocks During Operation	13
6C.	Delayed Ignition	13
6D.	Occasional Lockouts	13
	S9301A Control Module	14

SECTION 7.

Replacement Parts List

.....	17
-------	----

To the Installer: After installation these instructions must be given to the owner or left on or near the Water Heater.

To the User: This booklet contains important information that will help you in maintaining and operating this Water Heater. Please retain it for future reference.

Warning: Should overheating occur or the gas supply fail to shut off, turn off the manual gas control valve to the appliance.

Important: This unit must be installed in accordance with state and local codes by a qualified installer!

SECTION 1. Introduction & Unpacking

1A. Special Installation Considerations

BEFORE YOU BEGIN:

It is important for you to take a few minutes to review this Installation and Operating Instructions manual before you begin installation. This will make installing and operating the unit easier and faster.

Direct vent-sealed combustion.

The 9600 HWG Water Heater does not and should not take combustion air from inside the building. All of the air is drawn in from the outdoors through a 3-inch diameter plastic pipe. 3" PVC, ABS or CPVC pipe is used for air intake and exhaust venting. (PVC not permitted on HWG-M2-250 exhaust)

No chimney.....flue.....or draft inducer required. Because this is a sealed combustion, forced draft unit, it does not require, and **must not be connected to a chimney, existing venting system, or draft inducer.**

CAUTION

Connection of this vent to a chimney, existing venting system, or draft inducer will result in poor and possibly dangerous operation.

The supplied vent terminations are designed to be installed through the nearest outside wall (see Sections 2C and 2D).

The 9600 HWG Water Heater is protected against over pressurization. A 150 PSI pressure relief valve is fitted to the unit. It is installed in the dedicated fitting on the top of the water heater.

IMPORTANT: The inlet gas pressure to the appliance must not exceed 13" WC.

A high quality circulator is built into the 9600 HWG Water Heater and will provide sufficient head pressure and volume to circulate water to the storage tank(s) (see Table 3).

All installations must be made in accordance with the: 1) American National Standard Z223.1-Latest Edition "National Fuel Gas Code" and with the requirement of the local utility or other authorities having jurisdiction, or; 2) Can-CGA B149 installation code and / or local installation codes.

Such applicable requirements take precedence over the general instructions contained herein.

All electrical wiring is to be done in accordance with local codes, or in the absence of local codes, with: 1) the National Electrical Code ANSI/NFPA No. 70-latest Edition, or; 2) CSA standard C22.1 "Canadian Electrical Code - Pt 1. This appliance must be electrically grounded in accordance with these codes.

1B. Checklist of Materials Installer Must Provide

1. The following are acceptable materials for intake and exhaust vents:
 - a) 3" or 4" PVC sched. 40 pipe per ASTM D-1785 standard. (Not permitted on HWG-250 exhaust).
 - b) 3" or 4" PVC DWV pipe per ASTM D-2665 standard. (Not permitted on HWG-250 exhaust).
 - c) 3" or 4" ABS-DWV pipe per ASTM D-2661 or ASTM F-628 Standard.
 - d) 3" or 4" CPVC schedule 40 pipe per ASTM F441 standard.
 - e) The solvent cement for pipe joints is to comply with the following standards:
 - 1). PVC pipe D2564
ABS pipe D2235
CPVC pipe F493
 - 2). CSA listed solvent for a-d
2. Electrical connection to a 120VAC/15Amp service.
3. Gas connection that will provide 250 cubic feet/hour at 4 to 13 inch water gauge pressure.
4. Condensate drainage: a floor drain is preferred - a condensate pump may be used.
5. Miscellaneous copper fittings and bronze valves will be required to complete the piping system.

1C. Unpacking

The 9600 HWG Water Heater is shipped in a single carton with the following standard components on top of the unit (see Figure 1).

- 1) Exhaust terminal
- 2) Intake terminal
- 3) Vent terminal backing plate (4)
- 4) Hubless coupling reducer
- 5) Hubless coupling (2)

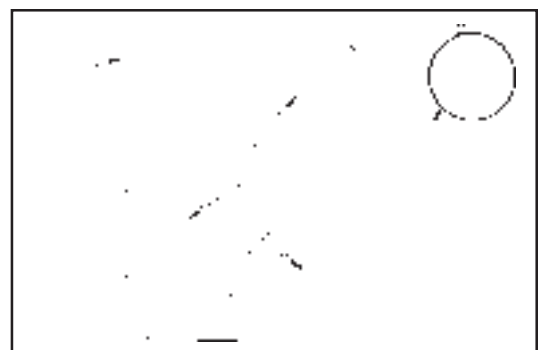

Figure 1. Contents of shipping package.

1. Remove all packing and tie-down materials.
2. Check contents of the carton against items shown above.

SECTION 2. Locating and Clearances

2A. Locating the 9600 HWG

The appliance should be located in an area where leakage of any connections will not result in damage to the area adjacent to the appliance or to lower floors of the structure.

When such a location is not available, it is recommended that a suitable drain pan, adequately drained, be installed under the appliance.

The unit is design certified by AGA / CGA for installation on combustible flooring; in basements; in closets, utility rooms or alcoves. It must not be installed on carpeting.

The location for the unit should be chosen with regard to the vent pipe lengths, external plumbing, ventilation of operating components and accessibility for service and cleaning.

If there is potential for snow accumulation in your area, both the vent terminals should be installed at an appropriate level above grade (see Figures 2 and 3).

The following dimensions and requirements should be met when choosing the location for the unit (see Table 1):

	Minimum Clearances From Combustible Construction	Recommended Clearance for Accessibility and Venting	
		AGA	CGA
	BOTH		
Left Side	1"	6"	48"
Right Side (Controls)	1"	12"	24"
Top	1"	14"	24"
Back	1"	9"	24"
Front	1"	24"	48"
Vent	0"		

Table 1. Location clearances.

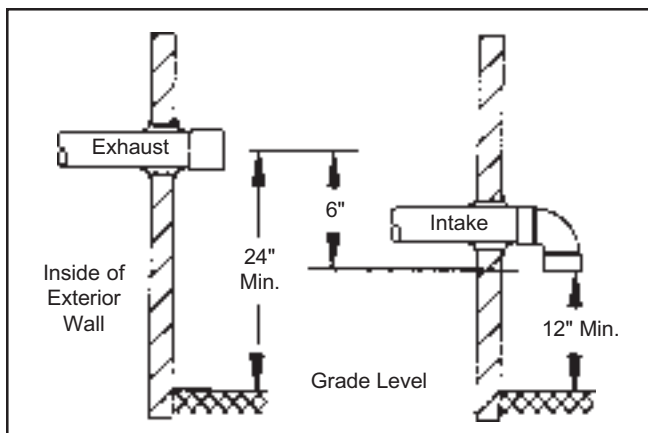

Figure 2. Suggested vent terminal installations.

2B. Locating the Unit for Proper Venting Distance from the Outside Wall or Roof Termination

Intake

Maximum run:
3" pipe size
55 equivalent feet

4" pipe size
85 equivalent feet

Minimum run:
11 equivalent feet

Intake Terminal is
P/N 2400-102.

Exhaust

Maximum run:
3" pipe size
55 equivalent feet

4" pipe size
85 equivalent feet

Minimum run:
21½ equivalent feet

Exhaust Terminal is
P/N 2400-104.

Equivalent feet is determined by adding 10 linear feet for each 90° elbow and 5 linear feet for each 45° elbow to be installed to the actual linear feet of pipe required.

Example: 8' of pipe, 2 x 45° elbows and a 90° elbow.

Equivalent Feet: 8' + (2 x 5') + (1 x 10') = 28.

If a 4" pipe size is used to permit longer vent runs the installer must supply 4" hubless couplings (2) and 3 x 4 bushings (2) to adapt to the unit fittings. 4" inlet and exhaust screens are provided for installation in contractor provided 4" coupling and elbow terminations.

NOTE: It is required that a minimum separation of 18" be maintained between the intake and exhaust terminals and that both terminals be installed on the same wall of the building. The intake terminal must not be installed above the exhaust terminal since this would tend to pull exhaust gases back into the intake (see Figures 2 and 3).

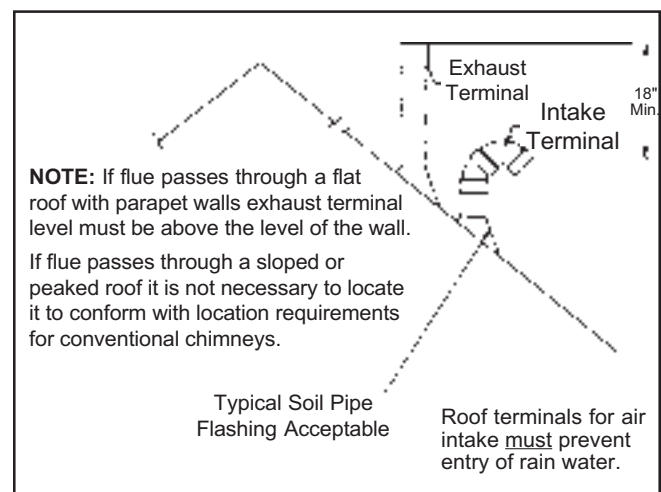

Figure 3. Alternate vent terminal installations.

2C. Locating Vent Openings on Outside Wall

1. Exhaust terminal location.
The exhaust terminal fitting requires a 4" (10cm) diameter hole through the outside wall. The center line of this opening must be at least 16" (41cm) above grade and at least 14" (35.6cm) from any other building opening such as doors, windows, etc.
Vent opening should be well away from shrubbery or other obstructions that would block or restrict the exhaust.
Whenever possible, locations under windows or near doors should be avoided. Steaming at the flue terminal is a normal occurrence. This should be considered when deciding flue terminal position.
2. Intake terminal location.
The intake terminal requires a separate 4" (10cm) diameter hole to install the intake fitting. The center line of the hole should be at least 16" (41cm) above grade outdoors and 18" (46cm) away from the exhaust outlet. The intake should never be located above the exhaust terminal.
3. Intake and exhaust location for multiple unit installation. For the installations of multiple units, refer to Figure 4 for intake and exhaust terminal locations.

2D. Locating Unit for Proper Vent Height

The vent locations you select must permit direct pipe runs to the terminal from the boiler. Since the 9600 HWG Water Heater is designed to drain any water that collects in the vent, it is important that you do not build any traps or low points into the vent where water could collect and restrict the vent. It is recommended that 1/4" per foot of vent be built into the vent system to direct any water in the vent back toward the boiler. Note that standard DWV elbows have a built in allowance for the required 1/4" per foot pitch.

2E. Locating Unit with Respect to Ventilation

While the 9600 HWG Water Heater requires no indoor air for combustion, adequate airflow around the unit must be provided for proper cooling of electrical components.

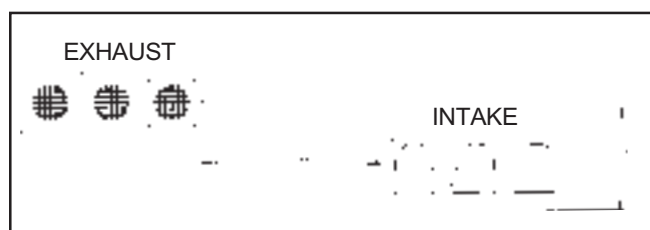

Figure 4. Multiple units minimum vent terminal separation.

2F. Locating Unit with Respect to Storage Tanks

For the best results the 9600 HWG Water Heater should be located within 10 feet of the storage tanks.

If the unit must be installed with longer piping runs, then the larger diameter tubing must be used. Calculate the necessary pipe size for your installation (see Table 2).

SECTION 3. Installation

3A. Installing Vent Piping Terminal

The water heater is provided with intake and exhaust terminals for use with 3" diameter plastic pipe.

The installer is responsible for obtaining the vent pipe and fittings. The maximum combined length of the intake and exhaust pipe and maximum number of elbows are determined by using the guidelines on Page 4.

The following steps are recommended for vent installation:

1. Obtain the necessary 3" or 4" diameter plastic piping and fittings as determined beforehand.
2. Position unit at previously selected location.
3. Unpack vent terminals and vent terminal backing plates.
4. Cut holes in outside wall for vent terminals in the previously selected locations.
5. Mount the vent terminals' backing plates.
6. Fit all of the vent pipes together without cementing. Make sure that there are no water traps and that any pitch is inclined back towards the boiler.
7. Make sure that the flexible vent connections at the unit fit properly.
8. Begin cementing the intake and exhaust pipes, start at the vent terminals and work back towards the appliance. Note that the intake terminal is a 90 degree elbow fitting that is designed to face down.
9. Support both intake and exhaust pipes with hangers.

DO NOT RELY ON 9600 HWG TO SUPPORT PIPES.

Horizontal runs must be supported adjacent to each fitting and at 5ft. intervals between fittings. ABS pipe must be supported at 3ft. intervals.

10. Tighten the flexible couplings to connect the water heater to the vent pipes.

3B. Connecting Gas to the 9600 HWG Water Heater

1. The water heater requires gas at an inlet gas pressure of at least 4" WC and no greater than 13" WC. Check with your local gas utility or supplier for availability of these delivery pressures.
2. Referring to TABLE 2, size supply piping to keep flow capacity to the unit above 250 cubic feet per hour (CFH) per unit installed.
3. Run gas supply line in accordance with all applicable codes.
4. Locate and install manual shutoff valves in accordance with state and local requirements.
5. Install drip leg and ground joint union (see Figure 5).
6. All threaded joints should be coated with piping compound resistant to action of liquefied petroleum gas.
7. The 9600 HWG unit and its individual shutoff valve must be disconnected from the gas supply piping during any pressure testing of that system at test pressures in excess of 1/2 psig (3.45kpa). It must be isolated from the gas supply system by closing its individual manual shutoff valve during any pressure testing of the gas supply piping system at test pressures equal to or less than 1/2 PSIG (3.45kpa). Failure to do so will possibly result in damage to the gas control system.
8. The 9600 HWG Water Heater and its gas connections must be leak tested before placing the unit in operation.
9. Purge all air from gas lines.

Length of Pipe	Capacity of Pipe in MBTU/h (.6 Specific Gravity)		
	3/4"	1"	1-1/4"
10'	278	520	1,050
20'	190	350	730
30'	152	285	590
40'	130	245	500
50'	115	215	440
75'	93	175	360
100'	79	150	305
150'	64	120	250
Additional length to be added for each tee or bend:			
	1.7'	2.2'	2.7'

Table 2. Gas supply piping.

3C. Connecting Water System Piping, Fittings & Accessories

Installing tank & piping

The 9600 HWG can be used with several different types of readily available storage tanks. A

bronze circulating pump is built into the appliance. The pump draws water from the storage tank and pumps the water through the heater and back into the tank.

Position the storage tank(s).

At the previously selected locations, position the storage tank(s). Use Table 3 to determine the pipe size necessary to provide adequate flow between the 9600 HWG and the tank(s).

Hot water outlet piping, fittings, and accessories.

1. Begin piping to the tank from the hot water outlet at the top of the 9600 HWG cabinet.
2. Pipe the outlet from the relief valve (located on top of the unit) such that any discharge from the relief valve will be conducted to a suitable place for disposal when relief occurs. Do not reduce line size or install any valves in this line. The line must be installed to allow complete drainage of both the valve and the line.
3. Install a shut off valve in the piping between the thermometer fitting and the tank.

Cold water supply piping, fittings and accessories.

1. Install a strainer between the 9600 HWG and the system. For proper pipe size and distance limitations, refer to Table 3.
2. Connect a drain valve and a shut off valve to the 9600 HWG cold inlet. On multiple units install a check valve at each unit's cold water inlet.
3. Where check valves have been installed on cold water inlet piping, check to be sure system has an adequately sized expansion tank to allow thermal expansion to occur.

Hot water supply piping.

Follow the manufacturer's guidelines for completion of the hot water system connections.

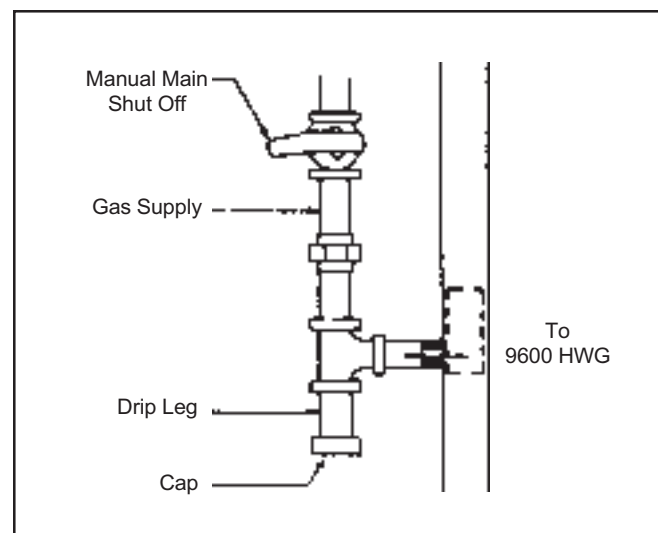

Figure 5. Gas supply piping.

NOTE: A listed temperature and pressure relief valve listed as complying with the Standard for Relief Valves and Automatic Gas Shutoff Devices for Hot Water Supply Systems, 1). ANSI Z21.22 latest edition, or 2). CAN / CGA 1 - 4.4, of suitable discharge capacity must be installed in the separate storage tank system.

3D. Tank Temperature Control

The 9600 HWG is turned on and off by a remote tank aquastat. Locate the aquastat above the cold water inlet fitting in the separate storage tank. The 9600 HWG draws water off the bottom of the tank and pumps hot water back into the tank. When the hot water level reaches the level of the aquastat, the aquastat switch will open and turn off the 9600 HWG.

Please contact your factory representative if you have any questions about storage tank application.

If a water heater is installed in a closed water supply system, such as one having a backflow preventer in a cold water supply line, means shall be provided to control thermal expansion, such as a properly sized potable water expansion tank.

If the relief valve on the appliance discharges periodically, this may be due to thermal expansion in a closed water supply system. Contact the water supplier or local plumbing inspector on how to correct this situation. Do not plug the relief valve.

No valves shall be placed between the tank T & P relief valve and the tank. Pipe the outlet from the relief valve such that any discharge from the relief valve will be conducted to a suitable place for disposal when relief occurs. Do not reduce line size or install any valves in this line. The line must be installed to allow complete drainage of both the valve and the line.

3E. Condensate Drain Connection

A black plastic fitting (labeled CONDENSATE) is located on the side of the cabinet. This fitting will accept 1/2" OD plastic tubing.

1. Connect a plastic tube between the fitting and the floor drain or condensate pump if a floor drain is not accessible.

NOTE: Connecting tubing must run **DOWNWARDS** from the level of the fitting. See Figure 8.

2. Above the fitting is a hole in the cabinet. Behind this hole is a 1/2" OD tube which serves as a condensate relief if the lower drain becomes blocked (see Figure 9).

Copper tube or pipe size	Maximum allowable tubing length	Amount deducted for each additional 90° elbow	Amount deducted for each additional 45° elbow
1¼"	40'	2'	1½'
1½"	120'	2'	1½'
2"	270'	2'	1½'

Note: This unit must be installed in a pressurized closed system that maintains a minimum of 10 psi static pressure.
 * If water hardness is greater than 10 grains, a water softening or particle suspension device must be installed before the heater, or warranty will be void.

Table 3. Water pipe and tube sizing between unit and tank.

3. Run this condensate relief tube through the hole in cabinet and to a drain pan. **DO NOT** pipe in common with condensate drain fitted in A above.

3F. Electrical Connections

All electrical wiring must conform to local codes and/or the 1). National Electrical Code ANSI/NFPA No. 70-Latest Edition, or 2). The CSA Standard C22.1 "Canadian Electrical Code - Part 1".

Single pole switches, including those of safety controls and protective devices must not be wired in a grounded line.

All electrical connections are made in the field wiring box which is located on the left side of the unit.

NOTE: All internal electrical components have been prewired. No attempt should be made to connect electrical wires to any other location except the wiring box designated above.

Wiring connections are indicated on the wiring diagram (see Figure 10).

3G. Main Power

Connect a 15 amp, fused, 120-volt supply to the main power switch (hot leg is connected directly to switch). Neutral leg is connected directly to the white wire. Ground wire can be connected to the grounding screw in the box.

3H. Temperature Control

Connect the tank aquastat to the red and white/red wires marked "T". Do not connect two units to the same set of aquastat contacts.

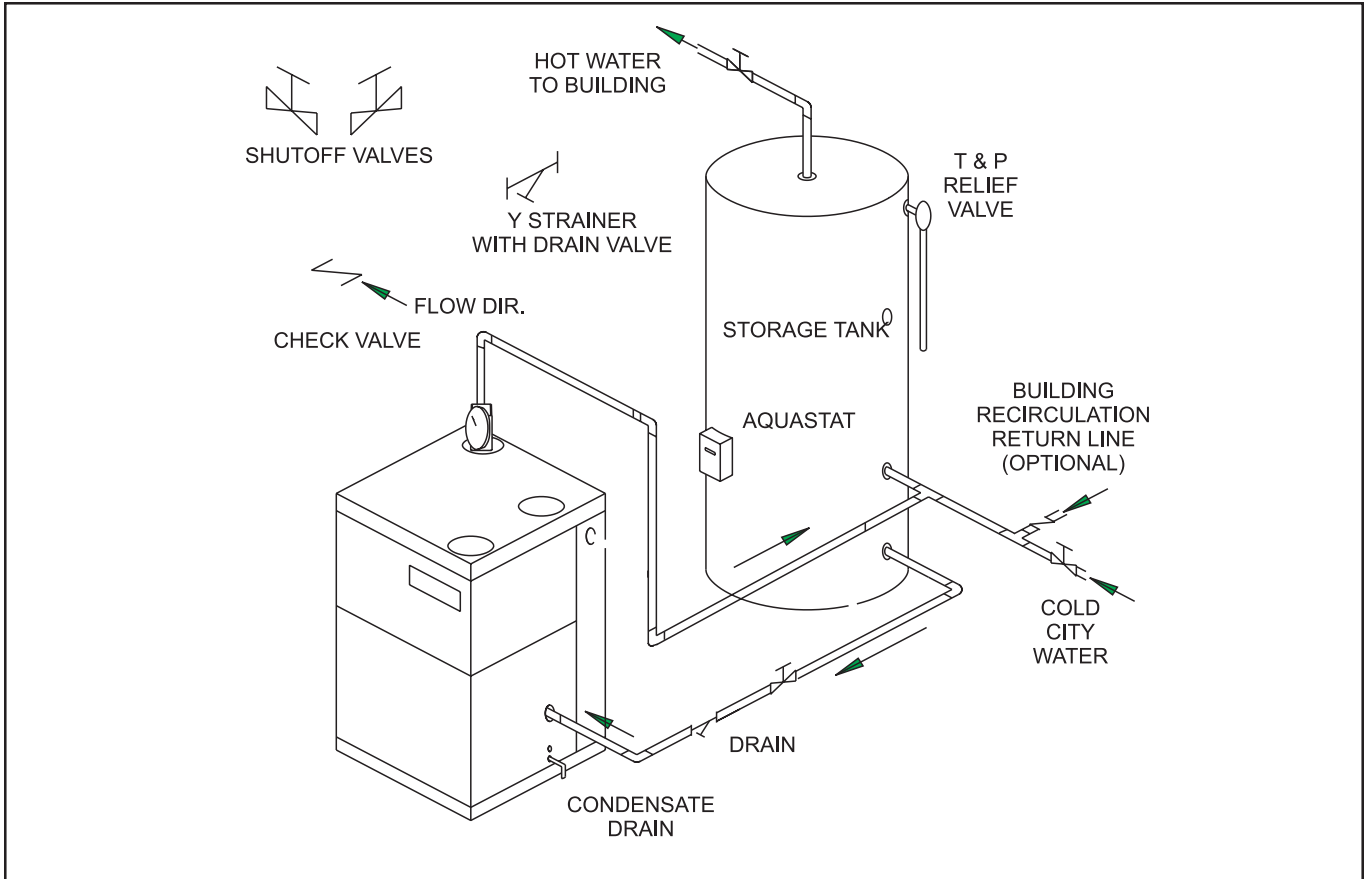

Figure 6. Single 9600 HWG & Storage Tank.

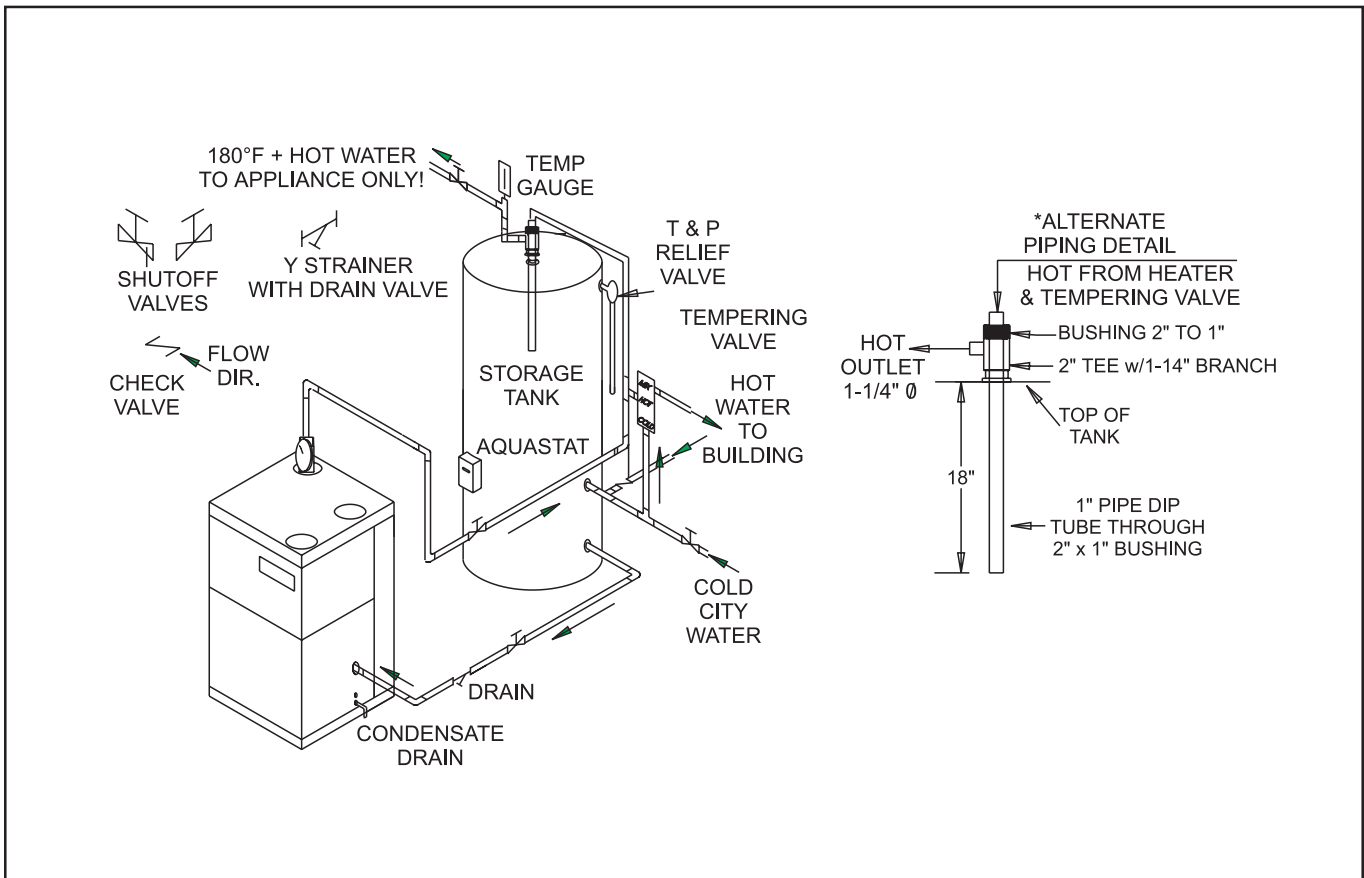

Figure 7. Two temperature system.

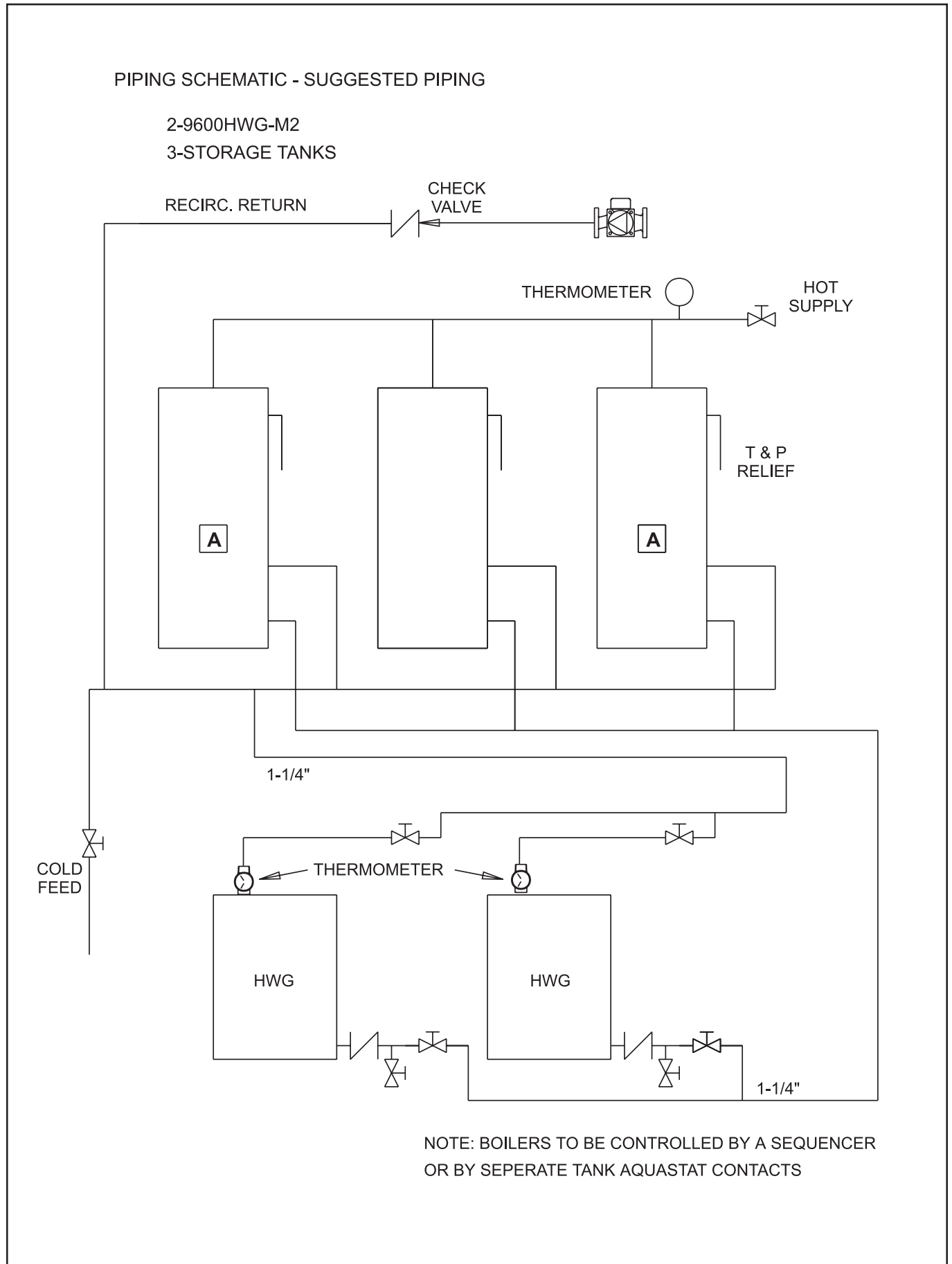

Figure 8. Multiple 9600 HWG's & storage tanks.

SECTION 4.

Start Up

4A. Filling the System

1. Open all valves.
2. Fill 9600 HWG Water Heater and the system completely.
3. Purge air from system. Bleed air from 9600 HWG using the air bleed at top of thermostatic valve inside unit under access plate on top panel.
4. Set aquastat to call for heat, turn on power at main switch for 30 seconds, then turn off.
5. Bleed 9600 HWG Water Heater and system again. After system is fully purged, the 9600 HWG Water Heater is ready for firing.

4B. Operation Checklist

1. Be sure that system has been filled properly (see above) and is leak tight.
2. Open gas cock(s) and open manual gas shutoff valve by turning to "on" position (see Figure 11).
3. Turn on main switch, set aquastat to call for heat.
4. Blower will come on.
5. **NOTE:** Burner may not ignite on first attempt because of air contained in gas lines. In this case blower will stop after 5 minutes. Should this happen, turn off main switch. Wait five minutes and turn on switch again. If burner fails three times, refer to Service Manual.
6. After placing the water heater in operation, the burner safety shutoff device must be tested. To test, disconnect ignitor plug at ignitor. Attempt to start appliance. After the burner control has completed three complete cycles the gas valve must not open again and the VALVE / FLAME light on the burner control must flash. Failure to

operate in this manner must be corrected by a qualified service contractor or gas company. Safe lighting and other performance criteria were met with the gas manifold and control assembly provided on the water heater when it underwent tests specified in ANSI Z21.10.3-Latest Edition and CAN / CGA 1 - 4.3 Latest Edition.

CAUTION: Should any pronounced odor of gas be detected or if the gas burner does not appear to be functioning in a normal manner, close main shut off valve and contact your heating contractor, gas company or factory representative.

7. Changing the gas orifice.
A 9600 HWG tune-up kit is available from your supplier. It contains a larger (marked +) and smaller orifice (marked -). If the firing rate is low, install the larger diameter orifice. Shut off electricity and gas to the unit. Loosen the gas orifice union (see Figure 12) and move the lower half of the union far enough to the side to remove the orifice. Change orifice. Reassemble, turn on gas and power and recheck the burner input.
8. It is recommended that the unit be checked with a standard CO₂ or O₂ tester. Insert tester probe at least 6" into the exhaust pipe through the outside vent terminal. Readings should be as follows:

CO₂ - 8% to 8.75% natural gas

O₂ - 6.9% to 5.5%

CO₂ - 9.25% to 9.75% propane gas

NOTE: This is a sealed combustion unit with the air orifice and gas valve factory set. They must not be altered or adjusted. If the firing rate cannot be obtained with the orifices supplied or if CO₂ or O₂ readings do not fall within the above ranges, contact your factory representative.

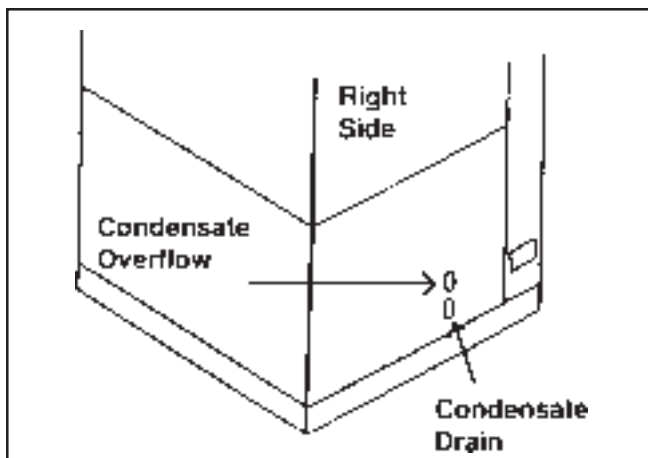

Figure 9. Condensate drain tube outlet.

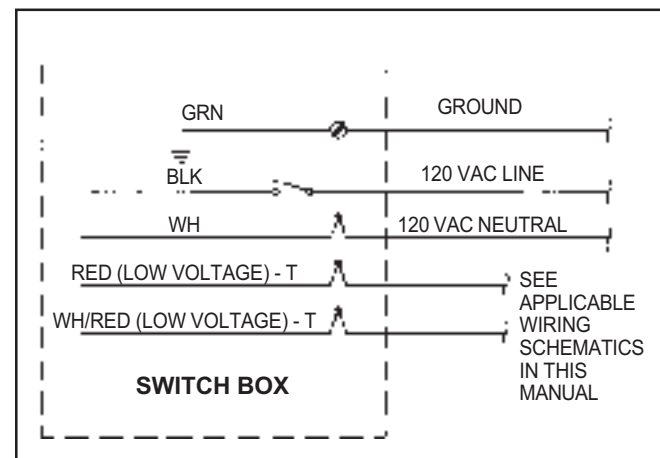

Figure 10. Electrical hook-up.

9. Using the temperature gauge, check the unit outlet temperature after three to four minutes of operation. Minimum operating temperature 160°F.
10. Shutdown instructions.
Turn off all Electrical power to the unit at main power switch located on Field Wiring Box cover. Turn gas cock dial to “off” position.
3. Remove the lower front panel from the water heater and connect a hose to the drain fitting. (Located under the cylindrical chamber). Relieve pressure at drain.
4. Connect a hose to the drain (provided by installer) on the cold (return) side piping to the appliance.
5. Remove cover from thermostatic valve and remove thermostat. Wrap tape around / over cutaway sections in the cover and replace all parts except thermostat. Reinstall valve cover and tighten bolts.
6. Fill the water heater combustion coil with deliming solution from the hose connected under boiler coil assembly until it exits from upper hose. A small pump should be used to do the filling from a plastic container. The upper hose should then be placed in this container and the pump should run until the circulating solution is no longer foamy.
7. Shut off pump and disconnect from hose. Carefully drain solution from hoses and connect city water to lower hose to flush combustion coil. Flush for approximately 5 minutes with city water.
8. Remove hoses, close drain cock, close drain on cold / return, and replace lower front panel .
9. Remove cover from thermostatic valve and remove tape. Replace thermostat, spring, brass ring and valve cover, and tighten bolts.
10. Open shut off valves and purge air from petcock at top of thermostatic valve cover.
11. Re-open gas supply and turn on main disconnect switch to return heater to service.

SECTION 5. Maintenance

5A. Owner Care and Maintenance

1. Inspect venting system annually. Inspect the outside vent terminal fittings to make sure that they are free of obstructions. Clean if necessary.
2. Inspect the condensate drainage system - this can be done by removing the screws that secure the lower front panel to the unit. There should be no signs of water leakage from any of the visible fittings or hose (see Figure 9).
3. The pressure relief valve should be operated manually at least once a year. To do this place a suitable container under the relief valve drain pipe. The discharge from this valve will be at high pressure and temperature. Make sure that overspray of hot water will not cause damage or bodily harm. Use the relief valve handle to discharge water into the container.

NOTE: Do not use this appliance if any part has been under water. Immediately call a qualified service technician to inspect the appliance and to replace any part of the control system and any gas control which has been immersed.

Keep appliance area clear and free from combustible materials, gasoline and other flammable vapors and liquids.

NOTE: There are no moving parts requiring any lubrication in this unit.

Keep appliance area clear and free of items that could obstruct ventilation air around the water heater.

SERVICE MAINTENANCE - To be done by a qualified service person.

5B. Routine De-Liming Procedure

CAUTION: Use all protective gear and precautions suggested by deliming solution manufacturers.

In hard water areas, this should be done on a regularly scheduled basis. (If water hardness is over 10 grains, a water softening system must be installed.)

1. Close the gas cock or manual gas shutoff (see Figure 11) and shut off the main disconnect switch.
2. Isolate the 9600 HWG unit from the system by closing the shutoff valves. If recirc. lines are piped, isolate the return system from water heater.

5C. Thermostat Replacement

1. Isolate the water heater and relieve pressure.
2. Remove the screws (4) and access cover from the jacket top.
3. Remove the hex head machine screws (3) from the top of the thermostatic valve, remove the valve top and internal parts.
4. Install new parts (P/N 2400-130).
5. Install new O-ring valve top and replace valve top on valve and install and tighten screws
6. Restore pressure to water heater, bleed air from the petcock on the valve and restart water heater.
7. Replace access cover.

5D. Vent and Condensate Drain Inspection (performed annually)

1. Inspect the vent terminals for blockage or restrictions.

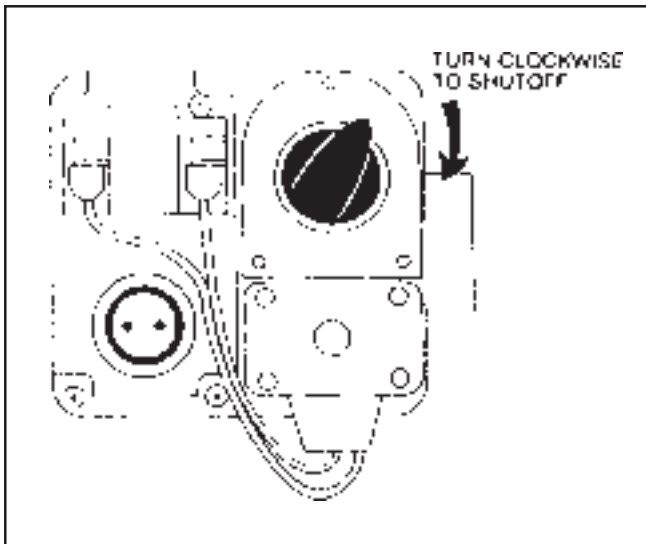

Figure 11. Manual gas shutoff.

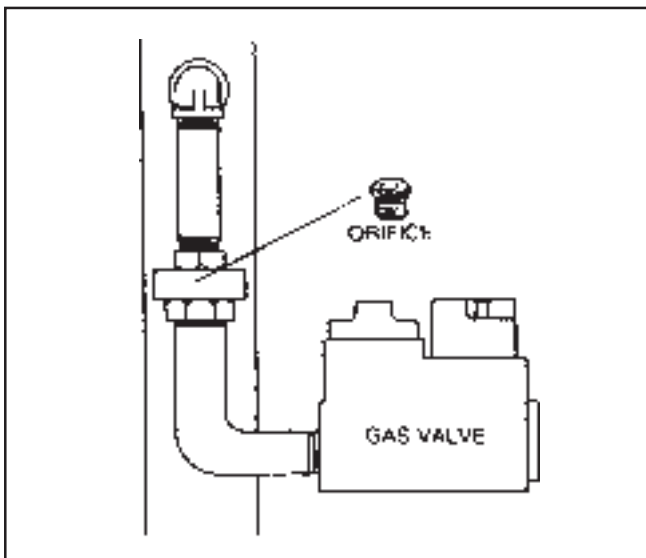

Figure 12. Gas orifice union.

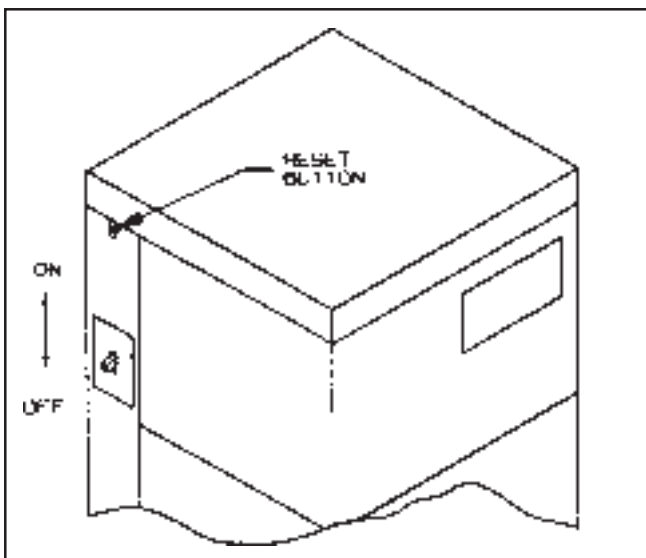

Figure 13. Switch location.

2. Check the condition of the internal vent fittings and hose and replace as necessary.
3. Check the condensate drain lines for blockage and optional condensate pump for proper operation.

5E. Cleaning Combustion Chamber Coil and/or Burner

Note: In normal operation this procedure is seldom required. Should it prove necessary, the following procedure is used to access the coil for cleaning (see Figure 14).

1. Turn off the gas and electrical power to unit and remove covers to the unit.
2. Remove water heater plastic exhaust assembly by undoing the four nuts that hold the plastic flange to the lower head. Disconnect one or more of the rubber vent couplings above the tee, and pull the elbow and tee out from under unit.
3. Shut off water to the system and disconnect and remove the water inlet connection.
4. Separate the union on the economizer pipe and remove the lower half of the union from the economizer outlet.
5. Undo the four economizer retainer nuts. (see Figure 14). Remove the boiler drain valve.
6. Undo the four clamps that hold the outer shroud to the upper head. (see Figure 14)
7. Drop the economizer, inner shroud and outer shroud together by separating the upper head and outer shroud.
8. Clean combustion coil with a wire brush.
9. Reassembly is done in reverse order. Use silicone sealer to seal joint between upper head and outer shroud.

5F. Combined Water (potable) Heating and Space Heating

(see Figure 15)

Piping and components connected to this water heater for the space heating application shall be suitable for use with potable water.

Toxic chemicals, such as used for boiler treatment, shall not be introduced into the potable water used for space heating.

This water heater when used to supply potable water shall not be connected to any heating system or component(s) previously used with a nonpotable water heating appliance.

When the system requires water for heating at temperatures higher than required for other uses, an anti-scald mixing or tempering valve shall be installed to temper the water for those uses in order to reduce scald hazard potential.

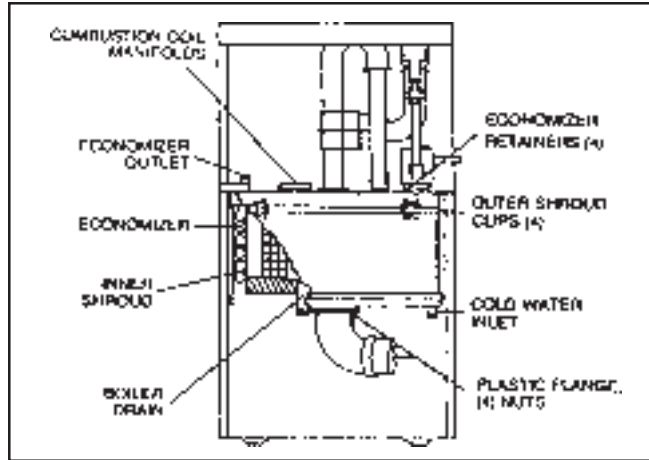

Figure 14. Cutaway view.

SECTION 6. Quick Reference Trouble Shooter

6A. Short Cycling

1. Tank aquastat set too high
2. Units shut down before reaching limit. Continuously restarts without resetting
 - a.) Limit out of calibration
 - b.) Wrong air/gas orifices for input or fuel (refer to 9600 gas orifice chart ONLY)

6B. 9600 Overheats Quickly or Knocks During Operation

Boiling noise in combustion chamber.

1. Air in combustion coil or in pump: Purge system.
2. Pump failure or control failure.

3. 9600 HWG lime buildup in primary heat exchanger.
4. Restriction in storage tank piping.
5. Defective thermostatic valve element.

6C. Delayed Ignition

Unit starts or stops with a “pop”.

1. Wrong gas orifice for fuel or air orifice size.
2. LP-Gas regulator lock up 3" or greater above run pressure: correct regulator and check gas pipe sizing against piping chart in installation manual. Set regulator for maximum run pressure of 9".
3. Remove blower and inspect flame holder (burner) for hole.
4. Check that the blower flanges and gas piping are sealed.

6D. Occasional Lockouts

Requires interruption of power or reset of safety limit to re-start.

1. Air in system causes safety limit to open. Vent air from system and eliminate source of air.
2. Condensing in primary heat exchanger or moisture in combustion chamber.
 - a.) defective element in thermostatic valve.
 - b.) improper installation of intake terminal.
 - c.) blocked condensate and condensate overflow system.
3. Poor Combustion - check CO₂ or O₂.
4. Intermittent ignitor failure: defective ignitor gasket allows ignitor base to overheat.
5. Occasional failure of blower: red “PURGE” light will be flashing.

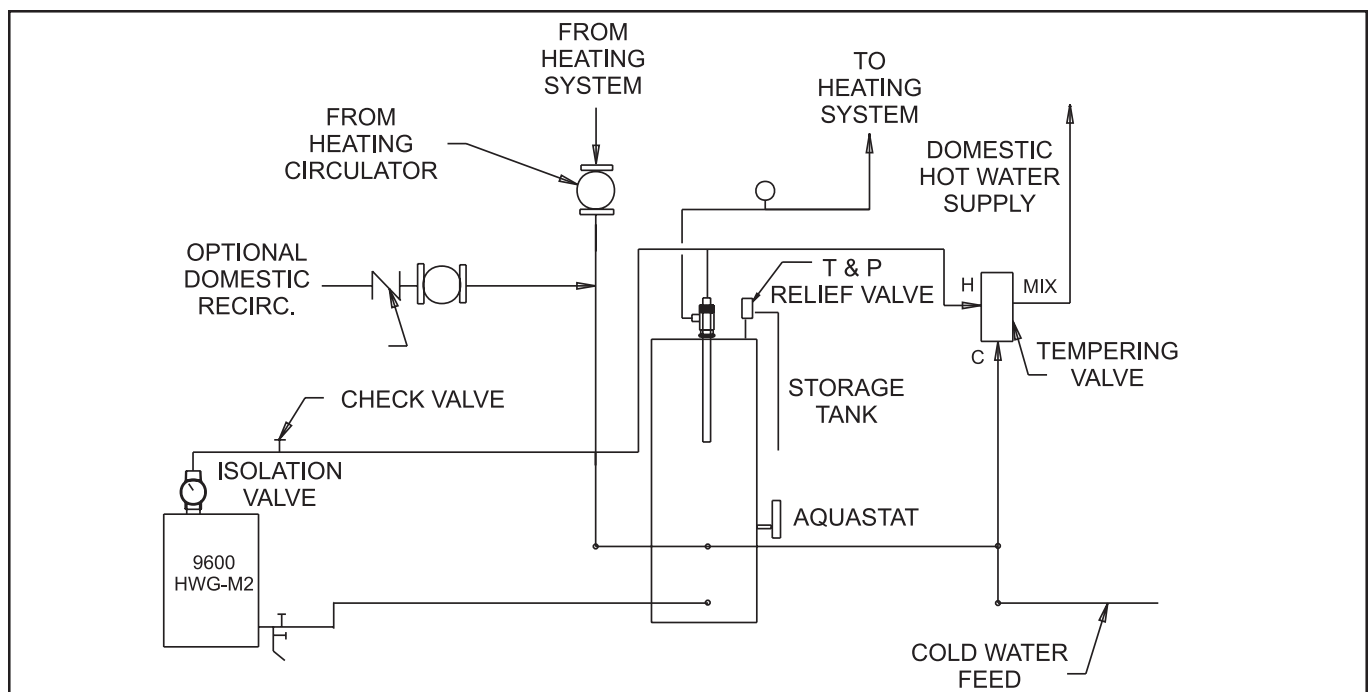

Figure 15. Typical installation.

Quick Reference Trouble Shooter S9301A Control Module

NORMAL SEQUENCE		
EVENT	CONTROL FUNCTION VERIFIED	LIGHT CONFIRMS EVENT
A. Power switch on.	Integrated boiler control (S9301A).	Green "POWER" light on. Note: If internal pump is running unit may be in lockout. Reset power switch.
B. Pre-purge low limit aquastat or thermostat calling (2-17 secs).	1. Internal pump starts.	Red "PURGE" light on NOTE: If unit is in purge mode without light, stack switch is not proving air flow.
	2. Low limit (HW-only), operating control, safety limit, system or differential pressure switch, stack switch.	
	3. Blower starts.	
C. Ignitor heats up and remains on (17-39 secs).	Ignitor via S9301A.	Red "IGNITOR" light on. Red "PURGE" light off. Blower continues to run.
D. Gas valve energized (37-43 secs).	Gas valve opens.	Red "VALVE/FLAME" light on.
E. Ignitor off (39 sec) Gas valve energized (39 - 43+ sec).	Ignitor, air & gas source.	Ignitor monitors flame via flame rectification to ground (0.6 - 1.0 microamps).

FAILURE TO COMPLETE EVENT CYCLE	
NO LIGHT OR BLINKING LIGHT	ACTION FOR DIAGNOSIS
1. No. 120 VAC supply.	1. Read voltage between black & white wires at back of (120 VAC) plug.
2. Defective 24 VAC transformer (Check 3 AMP inline fuse).	2. Read voltage between yellow wires at back of (VAC 24XFMR) plug.
3. Defective S9301A module.	3 Replace S9301A module part #2400-224.
1. Internal pump defective or air bound.	1. Check for 120 VAC at module pins marked "CIRCULATOR" (opposite brown & white).
2. Defective low limit, operating control, safety limit, or system differential pressure switch.	2. Jump control wires, one control at a time to identify open circuit in control (no continuity) FOR DIAGNOSIS ONLY.
3. Defective inducer (blower).	3. Check for 120 VAC at module pins marked "INDUCER" (opposite gray and white wires).
Ignitor does not heat up - look for heat up at ignitor base.	Check for 120 VAC at pins marked IGNR (blue wires) during "IGNITOR" light "ON".
1. Stack switch does not confirm air flow. 2. Gas valve has short.	Check for 24 VAC between orange and yellow wires on gas valve when red "VALVE/FLAME" light is on.
Unit transfers to purge 12-15 seconds after valve/flame light on and repeats sequence.	See trouble shooting section under "cross contamination" and "short cycling" in service manual.

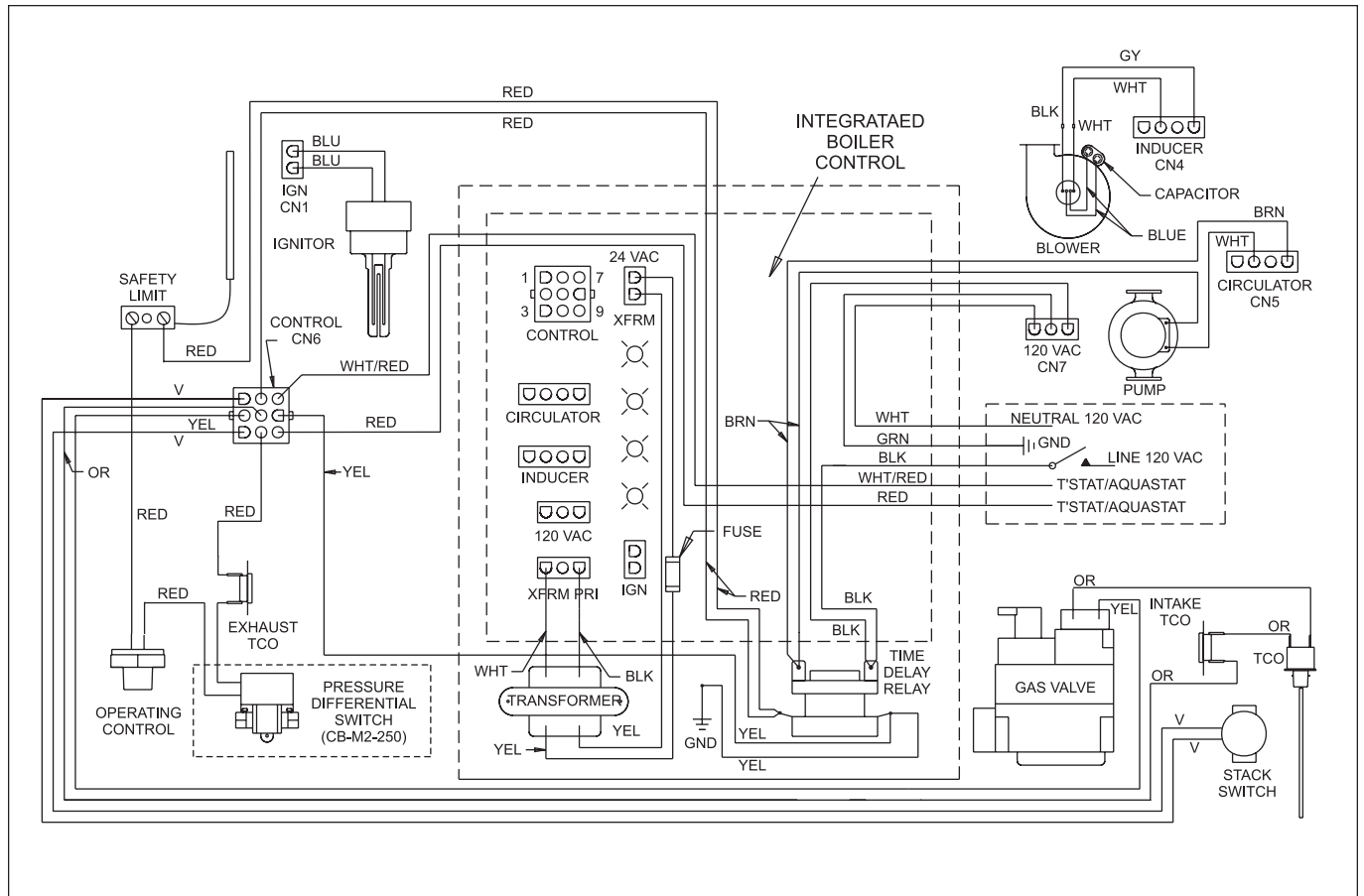
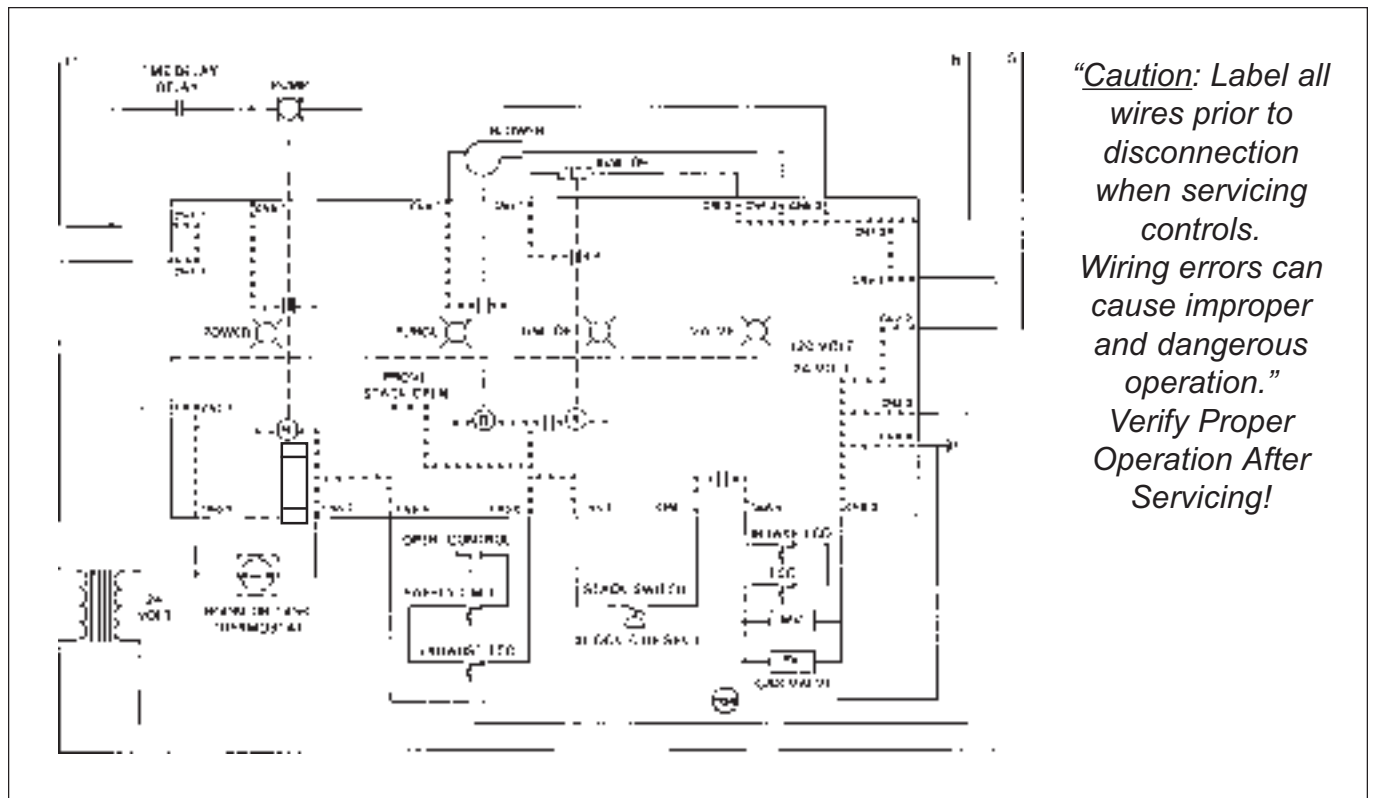

Figure 16. Wiring diagram.



“Caution: Label all wires prior to disconnection when servicing controls. Wiring errors can cause improper and dangerous operation.” Verify Proper Operation After Servicing!



Figure 17. Ladder diagram.

FOR YOUR SAFETY READ BEFORE OPERATING

WARNING: If you do not follow these instructions exactly, a fire or explosion may result causing property damage, personal injury or loss of life.

- A This appliance does not have a pilot. It is equipped with an ignition device which automatically lights the burner. Do not try to light the burner by hand.
- B **BEFORE OPERATING** smell all around the appliance area for gas. Be sure to smell next to the floor because some gas is heavier than air and will settle on the floor.
- WHAT TO DO IF YOU SMELL GAS**
- Do not try to light any appliance.
 - Do not touch any electric switch; do not use any phone in your building.
 - Immediately call your gas supplier from a neighbor's phone. Follow the gas supplier's instructions.
- If you cannot reach your gas supplier, call the fire department.
- C Use only your hand to push in or turn the gas control knob. Never use tools. If the knob will not push in or turn by hand, don't try to repair it, call a qualified service technician. Force or attempted repair may result in a fire or explosion.
- D Do not use this appliance if any part has been under water. Immediately call a qualified service technician to inspect the appliance and to replace any part of the control system and any gas control which has been under water.

OPERATING INSTRUCTIONS

- 1 STOP! Read the safety information above on this label.
 2. Make sure system has been properly filled with water and thoroughly bled of air; set the thermostat to lowest setting.
 3. Turn off all electric power to the appliance.
 - 4 This appliance is equipped with an ignition device which automatically lights the burner. Do not try to light the burner by hand.
 5. Remove control access panel.
 6. Push in gas control knob slightly and turn clockwise  to "OFF".
- NOTE: Knob cannot be turned to "OFF" unless knob is pushed in slightly. Do not force.
7. Wait five (5) minutes to clear out any gas. Then smell for gas, including near the floor. If you smell gas, STOP! Follow "B" in the safety information above on this label. If you don't smell gas, go to the next step.
 8. Turn gas control knob counterclockwise  to "ON."
 9. Replace control access panel.
 10. Turn on all electric power to the appliance.
 11. Set thermostat to desired setting.
 12. If the appliance will not operate, follow the instructions "To Turn Off Gas To Appliance" and call your service technician or gas supplier.

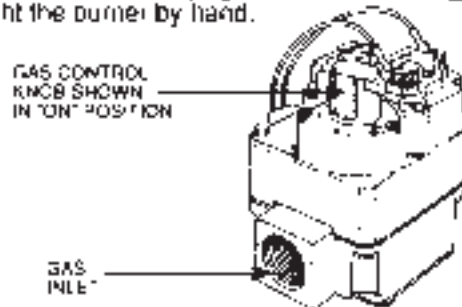

TO TURN OFF GAS TO APPLIANCE

- 1 Set the thermostat to lowest setting.
- 2 Turn off all electric power to the appliance if service is to be performed.
- 3 Remove control access panel.
4. Push in gas control knob slightly and turn clockwise  to "OFF." Do not force.
5. Replace control access panel.

Figure 18. Lighting and shutdown procedures.

SECTION 7. Replacement Parts List

Part Number	Description
2400-322	Gasket Kit
2400-079	Blower Assembly (#5)
2400-310	Blower Assembly (HWG-250)
2400-086	Combustion Coil Assembly (#9)
2400-082	Flame Holder (#7)
2400-308	Flame Holder (HWG-250)
2400-286	Ignitor
2400-088	Capacitor, Motor Starter
2400-224	Control Board
2400-014	Gas Valve, Neg. Pres. (#6)
2400-015	Gas Valve, Neg. Pres. (HWG-250)
2400-106	Pressure Diff. Switch (HWG-250)
2400-058	Intake / Exhaust TCO
2400-057	Operating Limit
2400-054	Safety Limit
2400-062	Time Dealy Relay
2400-130	Thermostat Kit (140°F) (#1)
2400-006	Transformer
2400-094	Pressure Relief Valve (150 psi)
2400-095	P.R. Valve (250 only) (150 psi)
2400-090	Pump, Grundfos Up 26-99BF (#2)
2400-104	Exhaust Terminal
2400-102	Intake Terminal
2400-100	Wall Flange

Note: Reference page 15 for electrical components

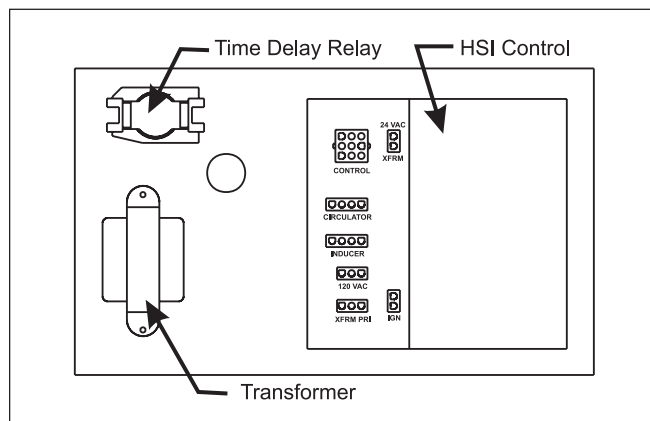

Figure 19. Control box.

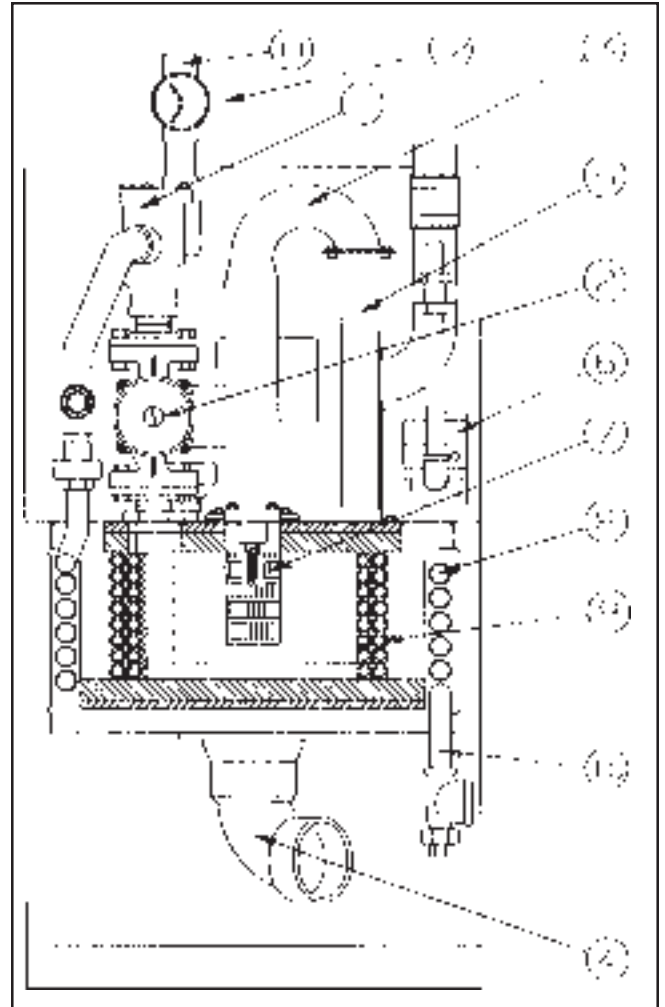

Figure 20. Assembly view of the unit.

- (1) Thermostatic Valve
- (2) Circulator
- (3) Mixer Tube
- (4) Exhaust Pipe
- (5) Blower
- (6) Gas Valve
- (7) Burner
- (8) Economizer
- (9) Combustion Coil
- (10) Water Inlet from Tank
- (11) Hot Water Outlet to Tank
- (12) Air Vent



Waterpik Technologies, Inc.
6000 Condor Drive, Moorpark, CA 93021 • 805.529.2000 • FAX 805.529.5934
20 Industrial Way, Rochester, NH 03867 • 603.335.6300 • FAX 603.335.3355
480 S. Service Road West, Oakville, Ontario, Canada L6K 2H4 • 905.844.8233 • FAX 905.844.2635
www.laars.com

