

Installation Instructions for the Trained Service Technician.

## Application

The T87F Universal Thermostat provides temperature control for 24 to 30 Vac residential heating, cooling or heating-cooling systems. For heating systems, the T87F mounts on the wallplate provided. For cooling only, or heating-cooling, order the 137421A (198170A if textured designer model) Heating-Cooling Wallplate with remote switching, or the Q539 Subbase, which provides switching at the thermostat location.

The spdt switch makes one set of contacts on a temperature fall to operate the heating system. The other set of contacts make on a temperature rise to operate the cooling system when the T87F is used to control cooling.

Heat anticipation is adjustable, 0.1 to 1.2A.



## Recycling Notice

This control contains mercury in a sealed tube. Do not place control in the trash at the end of its useful life.

If this control is replacing a control that contains mercury in a sealed tube, do not place your old control in the trash.

Contact your local waste management authority for instructions regarding recycling and the proper disposal of this control, or of an old control containing mercury in a sealed tube.

If you have questions, call Honeywell Inc. at 1-800-468-1502.

## Installation and Setting

### WHEN INSTALLING THIS PRODUCT...

1. Read these instructions carefully. Failure to follow them could cause a hazardous condition.
2. Check the ratings given in the instructions and on the product to make sure the product is suitable for your application.
3. Installer must be a trained, experienced service technician.
4. After installation is complete, check out product operation as provided in these instructions.



## CAUTION

1. Disconnect power supply to prevent electrical shock or equipment damage.
2. To prevent interference with the thermostat linkage, keep wire length to a minimum and run wires as close as possible to the subbase.
3. Do not overtighten thermostat captive mounting screws because damage to subbase threads can result.
4. Do not short across coil terminals on relay. This can burn out the thermostat heat anticipator.

**IMPORTANT:** An incorrectly leveled thermostat will cause the temperature control to deviate from set point.

### LOCATION

Install the thermostat about 5 ft [1.5m] above the floor in an area with good air circulation at average temperature.

Do not install the thermostat where it may be affected by:

- drafts, or dead spots behind doors and in corners.
- hot or cold air from ducts.
- radiant heat from sun or appliances.
- concealed pipes and chimneys.
- unheated (uncooled) areas such as an outside wall behind the thermostat.

This thermostat is a precision instrument and was carefully adjusted at the factory. *Handle it carefully.*

### MOUNTING WALLPLATE OR SUBBASE (Fig. 2)

#### IMPORTANT:

1. Use a plumb line or spirit level to accurately level the wallplate or subbase as in Fig. 1. Inaccurate leveling may cause thermostat control deviation.
2. When using the T87F with a Q539 Subbase, follow the mounting and wiring instructions included with the subbase.

1. Place the wallplate on the wall at the desired location. Pull the thermostat cable through the entrance hole.
2. Fasten wallplate. Do not tighten the screws.
3. Level according to Fig. 1 then tighten screws.
4. After wiring wallplate, plug hole to prevent drafts from affecting thermostat.

**NOTE:** To mount T87 Thermostat on an outlet box, order 129044A Adapter Ring Assembly.

**Fig. 1—Leveling wallplate or subbase with spirit level or plumb line.**

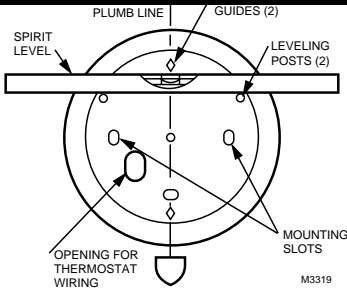

**Fig. 2—Mounting wallplate or subbase to wall.**

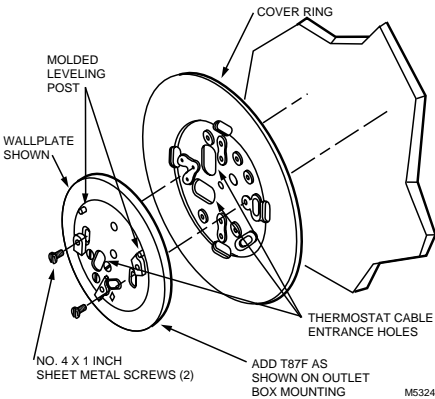

**WIRING**

All wiring must comply with local electrical codes and ordinances. Disconnect power supply before connecting wiring to prevent electrical shock or equipment damage.

The T87F is adaptable to most 2-wire, 24 to 30 volt heating systems, and to most 3-wire, 24 to 30 volt heating systems controlled by a Series 10 Thermostat. The following hookups are typical applications. See Figs. 3 through 7. When using the T87F for cooling control, refer to the hookups in the Q539 Subbase instructions.

For variations of these systems, refer to the installation instructions for the controlled equipment.

After wiring the wallplate, plug the hole to prevent drafts that may affect the thermostat.

**Fig. 3—T87F used for 2-wire, spst control of heating only in a typical oil system. Low voltage power for the control circuit is supplied by a transformer in the oil primary control.**

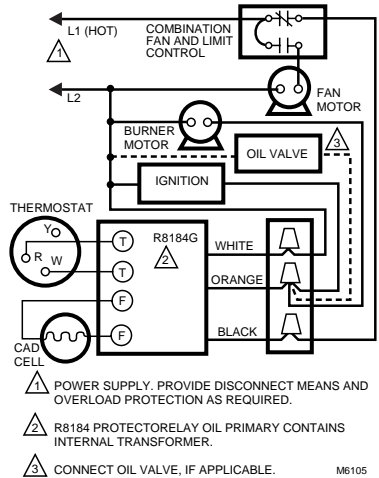

**Fig. 4—T87F used for 2-wire, spst control of heating only in a typical gas system.**

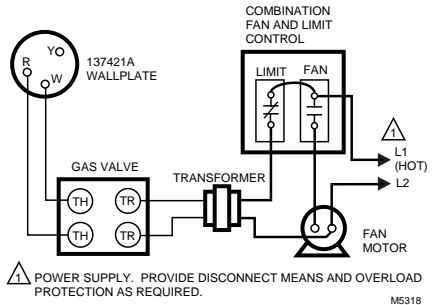

**Fig. 5—T87F replacing a Series 10 Thermostat connected to a 3-wire, open-contact, high-limit control.**

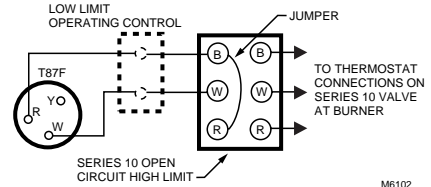

**Fig. 6—T87F used for Series 20, 3-wire, spdt control of low-voltage motors and electric radiator valves. Used in applications where thermostat makes contact on both a rise and fall in room temperature.**

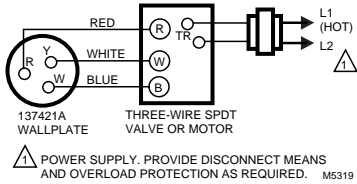

**Fig. 7—T87F used in cooling-only system.**

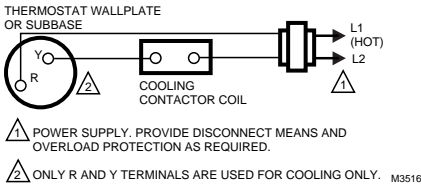

## MOUNTING THERMOSTAT TO WALLPLATE OR SUBBASE

To remove standard cover, pull ring outward with fingertips, pressing lightly on dial with thumbs.

To remove locking cover, loosen the three screws along the cover edge with the Allen wrench supplied. Remove the cover as indicated above.

Remove and discard the plastic insert protecting the mercury switch.

Align the thermostat over the wallplate and tighten the three captive mounting screws. These captive screws complete the electrical connections to the thermostat. Adjust heat anticipator to match current rating of primary control. See Fig. 8.

## HEAT ANTICIPATOR SETTING

If the T87F is used for 3-wire, spdt, heating-only (Series 20) control (Fig. 6), set the heat anticipator for 1.2 (far left end of scale). A fixed resistor-type heater is provided in the 137421A or 198170A Wallplate for this application. For other control applications, proceed as follows.

Adjust anticipator to match current rating of primary control. Rating is usually stamped on the control nameplate. Move the indicator to the marking that matches this rating. Indicator may be moved with fingers or pencil point through the hole shown in Fig. 8. If the current rating is not given, proceed as follows before mounting the thermostat:

1. Connect an ac ammeter of appropriate range (0 to 2.0A, for example) between the R and W terminals on the wallplate or subbase.

2. Let the system operate for one minute before reading the ammeter.

3. Move the anticipator indicator to match the ammeter reading.

A slightly higher setting to obtain longer burner-on times (fewer cycles per hour) may be desirable for some systems.

## RECALIBRATION

The T87F is calibrated at the factory and no recalibration should be necessary. If the thermostat is accurately leveled and still appears to be out of calibration, order 104994A Calibration Wrench. Instructions for recalibrating are furnished with the wrench.

**Fig. 8—Setting heat anticipator current rating.**

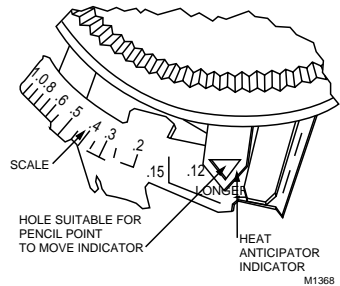

## Checkout

### HEATING

Turn down temperature setting to the lowest point. If subbase or remote switching is used, move system switch to HEAT position. Raise temperature setting until heating equipment starts. This point should be at room temperature as indicated on the thermometer. Slowly turn back dial. Heating equipment should stop when dial has been turned below room temperature.

### COOLING



## CAUTION

1. Do not operate cooling if outdoor temperature is below 50° F [10° C]. Refer to manufacturer recommendations.
2. Allow five-minute off-time after compressor has been run to avoid compressor damage.

If T87F controls cooling, move system switch (if used) to call for COOL and lower setting until cooling equipment starts. Raise setting above room temperature and cooling system should shut down. Make certain all equipment properly responds to the thermostat.

**Honeywell**

*Helping You Control Your World*

---

**Home and Building Control**

Honeywell Inc.  
1985 Douglas Drive North  
Golden Valley, MN 55422

**Home and Building Control**

Honeywell Limited—Honeywell Limitée  
740 Ellesmere Road  
Scarborough, Ontario  
M1P 2V9



QUALITY IS KEY