



HE365A,B Powered Flow-Through Humidifier

TRADELINE®

INSTALLATION INSTRUCTIONS

READ AND SAVE THESE INSTRUCTIONS

APPLICATION

The EnviraCaire Elite™ HE365A,B Powered Flow-Through Humidifier works with the warm air furnace blower to provide humidification for the whole house. The HE365A,B works with virtually any Honeywell humidity control, and can be integrated to the temperature control in the home when controlled by the Honeywell Perfect Climate Comfort Center™ control.

INSTALLATION

When Installing this Product...

1. Read these instructions carefully. Failure to follow them could damage the product or cause a hazardous condition.
2. Check the ratings given in the instructions and on the product to make sure the product is suitable for your application.
3. Installer must be a trained, experienced service technician.
4. After installation is complete, check out product operation as provided in these instructions.



CAUTION

Hazardous Voltage.
Improper drilling can cause equipment damage or personal injury.
Do not cut or drill into any air conditioning or electrical accessory.



CAUTION

Freezing Water, Flooding or Static Pressure Hazard.
Can cause water damage or permanent equipment damage.

- Locate the humidifier where the ambient temperature is between 32°F (0°C) and 160°F (71°C) or property damage can occur.
- Do not install humidifier where freezing temperatures could occur.
- Be sure supply plenum static pressure is no greater than 0.4 in. wc and water pressure is no greater than 125 psi.

IMPORTANT

- Mount the humidifier at least 3 in. (76 mm) above the furnace jacket to allow adequate space for the drain line. Check that there is adequate space above the humidifier to remove and install the humidifier cover. Do not install on a furnace jacket.

1. Determine the best location for the humidifier and draw a level line on the plenum. See Fig. 1 and 2.

IMPORTANT

To assure optimal product performance, be sure the template is level before marking.

2. Tape this piece of paper in position as your template and trace around the template.
3. Remove the template and carefully cut the rectangular opening.
4. Loosen the thumbscrew on the bottom of the humidifier and remove the cover.
5. Remove the humidifier pad assembly by grasping the top of the tray and pulling the assembly out of the housing. See Fig. 3.
6. Position the securing clips as shown in Fig. 4.

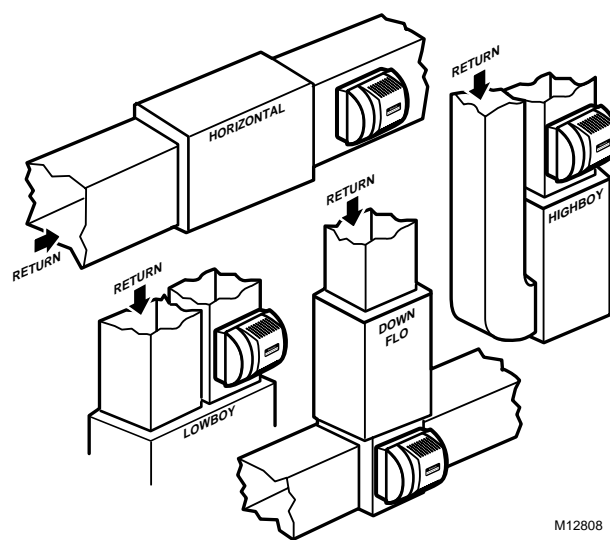

Fig. 1. Typical humidifier installation locations.

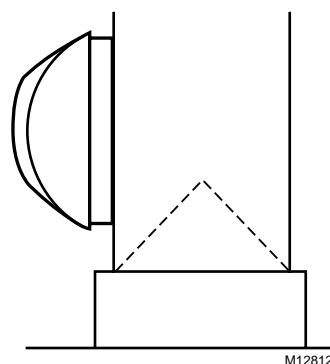

Fig. 2. HE360 Humidifier location in relation to air conditioning cooling coils.

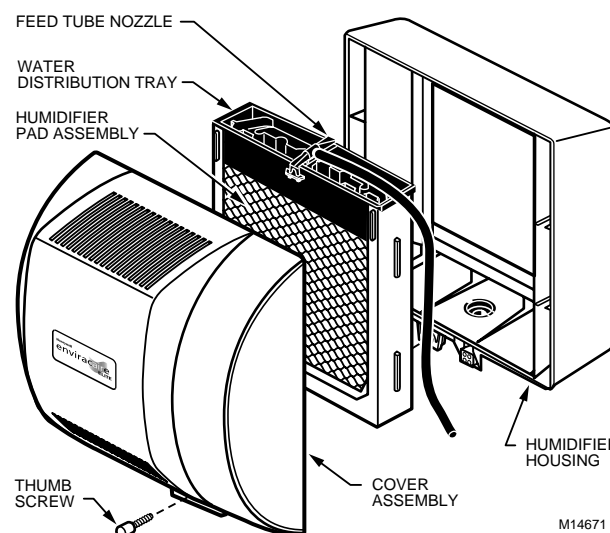

Fig. 3. Humidifier components.

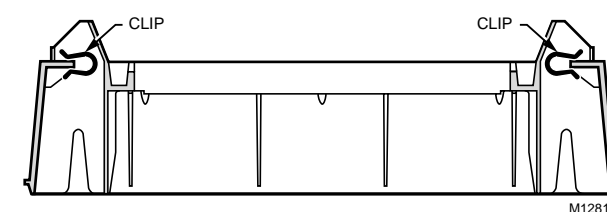

Fig. 4. Position securing clips.

7. Position the humidifier housing in the hole (be sure it is level), so the locking tabs are in place on the upper and lower sheet metal edge of the hole.
8. Push in securing clips until completely seated.
9. Drill holes and install the three sheet metal screws at the top of the humidifier housing. Secure the housing with the three remaining screws.
10. Reinstall the humidifier pad assembly in the humidifier housing.

IMPORTANT

For proper operation, be sure the mark on the end of the humidifier pad is facing up. Check that the water feed tube is placed in the guide slots of the humidifier housing.

11. Hook the top of the cover to the housing and secure with the thumbscrew located at the bottom of the cover.

WIRING

WARNING

- Voltage Hazard.**
Moving parts can cause electrical shock and injury.
- Disconnect power supply before installation or servicing.
 - This device contains a moving fan blade; do not operate the humidifier without the cover securely attached.

All wiring must comply with applicable local codes, ordinances and regulations.

For H808 Humidistat, H8908 or H908 Convertible Humidity Control Wiring Connections:

IMPORTANT

- Select models of fan centers include humidifier taps so the current sensing relay or sail switch is not needed.
- If not using a current sensing relay or sail switch, the 120V humidifier plug must be energized during blower motor cycles for proper operation.

1. Wire the current sensing relay or sail switch.
2. Connect only the two yellow wires to the humidistat (red wire connections are not used for mechanical humidistats). See the typical wiring diagrams in Fig. 5 through 7.

For additional mounting and wiring information, refer to the humidistat installation instructions.



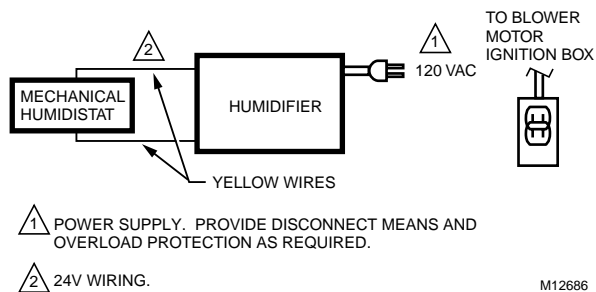

Fig. 5. Typical wiring diagram for humidifier using fan control to cycle blower motor fan and humidifier simultaneously.

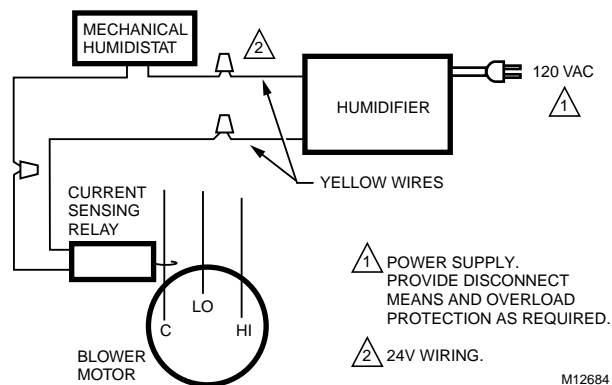

Fig. 6. Typical wiring diagram of current sensing relay with humidifier.

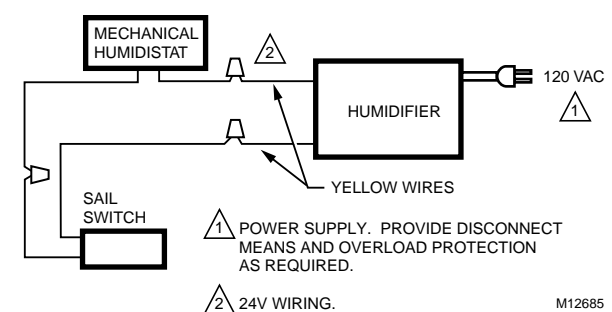

Fig. 7. Typical wiring diagram of sail switch with humidifier.

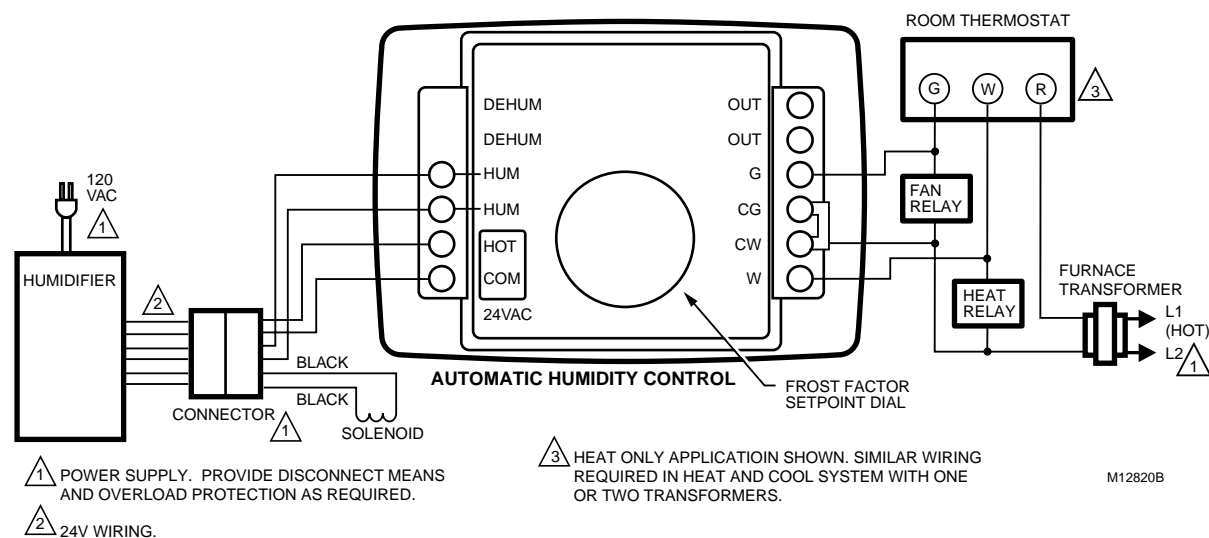

Fig. 8. Typical wiring diagram for humidifier using H1008A Automatic Humidity Control.

For H1008 Automatic Humidity Control wiring connections:

IMPORTANT

- Current sensing relay or sail switch is not needed with the Automatic Humidity Control.
- Use 18-22 gauge insulated wire for proper wiring. We recommend stranded - tinned wire.

1. Connect 24 Vac power to the 24 Vac HOT and COM terminals on the H1008A.
2. Connect the humidifier to the two HUM terminals on the H1008A as shown in Fig. 8.

For additional mounting and wiring information, refer to the Humidity Control installation instructions.

For Perfect Climate Comfort Center™ Control connections:

1. Connect only the two yellow wires to the W8900 (red wire connections are not used). See the typical wiring diagram in Fig. 9.

For additional mounting and wiring information, refer to the Perfect Climate Comfort Center™ installation instructions.

Plumbing Saddle Valve

Hot or cold water, either hard or softened, can be used in the humidifier.

1. Use the self-piercing saddle valve (included) to tap into the water supply line at an appropriate location.

CAUTION

Chemical Hazard.
Can cause personal injury or equipment damage.
Do not use any line connected to an air conditioner.

IMPORTANT

- The saddle valve is not designed to regulate water flow; the valve is either open or closed.
- To prevent debris from clogging the solenoid in-line filter, be sure to install the saddle valve handle pointing toward the ceiling.

NOTE: Lightly clean the copper tubing ends with fine sandpaper before making any connections.

2. Use 1/4 in. O.D. copper tubing and connect the saddle valve to the inlet side of the solenoid valve.
 - a. Place the brass compression nut over the copper tubing.
 - b. Slide the brass ferrule over the tubing.

NOTE: Do not over-tighten the compression nut. Moderate tightness prevents leaking.

- c. Insert the tubing into the solenoid valve fitting and support the valve while tightening the compression nut.

NOTE: Slope hose downward for correct drainage.

3. Connect a 1/2 in. hose to the humidifier drain fitting and run it to a suitable drain.

CHECKOUT

1. Open the saddle valve.

NOTE: The furnace blower must be on for the humidifier to operate.

2. Set the thermostat setpoint 10°F (6°C) above the room temperature.
3. Set the convertible humidity control to a high humidity setting, or place the H1008A Automatic Humidity Control in the test position.
4. Observe the water running out of the drain line to be sure the humidifier is working correctly.
5. Check for leaks.
6. Reset the thermostat to a comfortable setting or the Automatic Humidity Control to the desired frost factor setting.

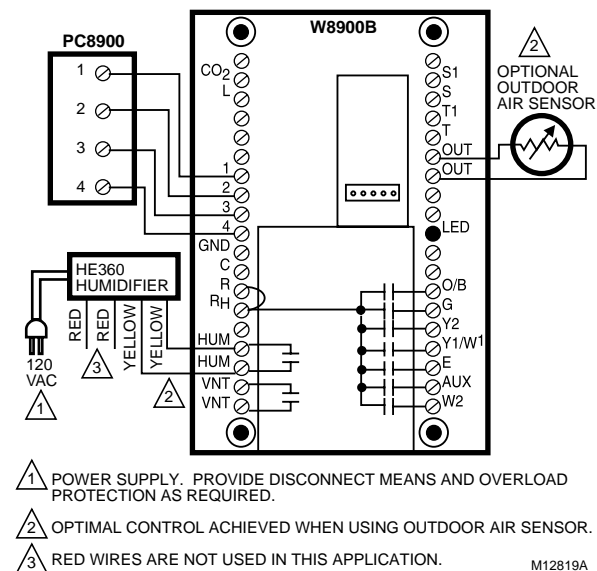

Fig. 9. Typical wiring diagram for humidifier using PC8900/W8900.