

## Honeywell CT3611 PROGRAMMABLE THERMOSTAT

### OWNER'S GUIDE

Seven Day  
Programmable Heat Pump  
Low Voltage (20 to 30 Vac) Thermostat and Wallplate  
Model CT3611

Para pedir estas instrucciones en español, llame al 1-800-468-1502.  
Pour obtenir ce ode demploi en français, composer le 1-800-468-1502.



### Table of Contents

Step 1. Prepare for Installation .....	5
Step 2. Remove Old Thermostat .....	5
Step 3. Mount thermostat Wallplate .....	6
Step 4. Wire Wallplate Terminals .....	7
Step 5. Mount the Thermostat .....	9
Step 6. Customize Your Thermostat .....	9
Step 7. Set the Clock .....	11
Step 8. Programming .....	12
Step 9. Operating Your Thermostat .....	15
Step 10. Set the Fan and System Switches .....	17
If You Have a Problem .....	18
Smart Response™ Technology .....	20
Wiring Diagrams .....	21



# TOTAL COMFORT TEMPERATURE MANAGEMENT WITH SMART RESPONSE™ TECHNOLOGY.

Congratulations! You made a smart choice by purchasing your new Honeywell thermostat; the smart thermostat that;

- *Keeps you comfortable* by automatically calculating exactly when the heat pump should go on to have the house at the desired comfort temperature by the time you wake up or return home.
- *Saves the maximum amount of energy and money* by automatically remembering to adjust the temperature when you leave home or go to sleep.
- *Provides the ultimate in comfort and convenience.* It comes preprogrammed. You can use the preprogrammed schedule, or set your own.

This manual answers many of the questions that can arise as you become familiar and comfortable with your Honeywell thermostat — the state of the art in home comfort controls.

Read these instructions carefully. Failure to follow these instructions can damage the product or cause a hazardous condition.



## MERCURY NOTICE

If this thermostat is replacing a control that contains mercury in a sealed tube, do not place your old control in the trash. Contact your local waste management authority for instructions regarding recycling and the proper disposal of this control, or of an old control containing mercury in a sealed tube.

If you have questions, call Honeywell Inc. at 1-800-468-1502.

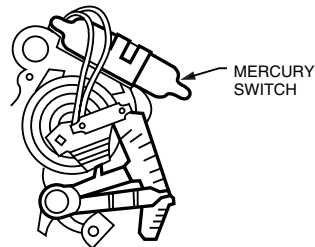

**TYPICAL LOCATION OF A MERCURY SWITCH IN A THERMOSTAT**

M10614

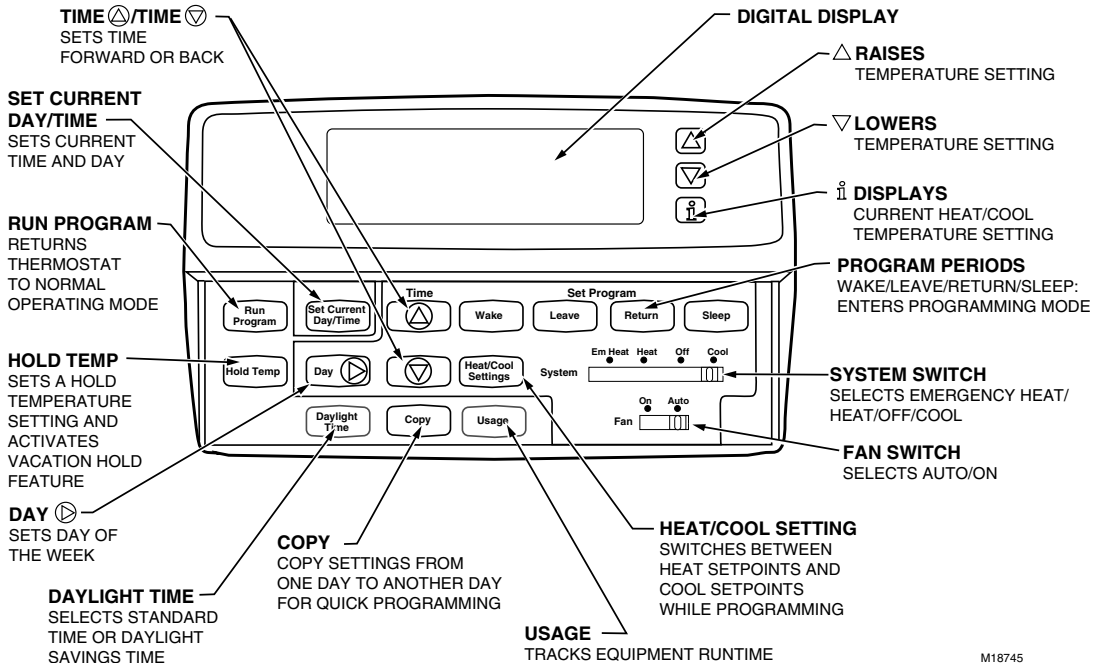

M18745

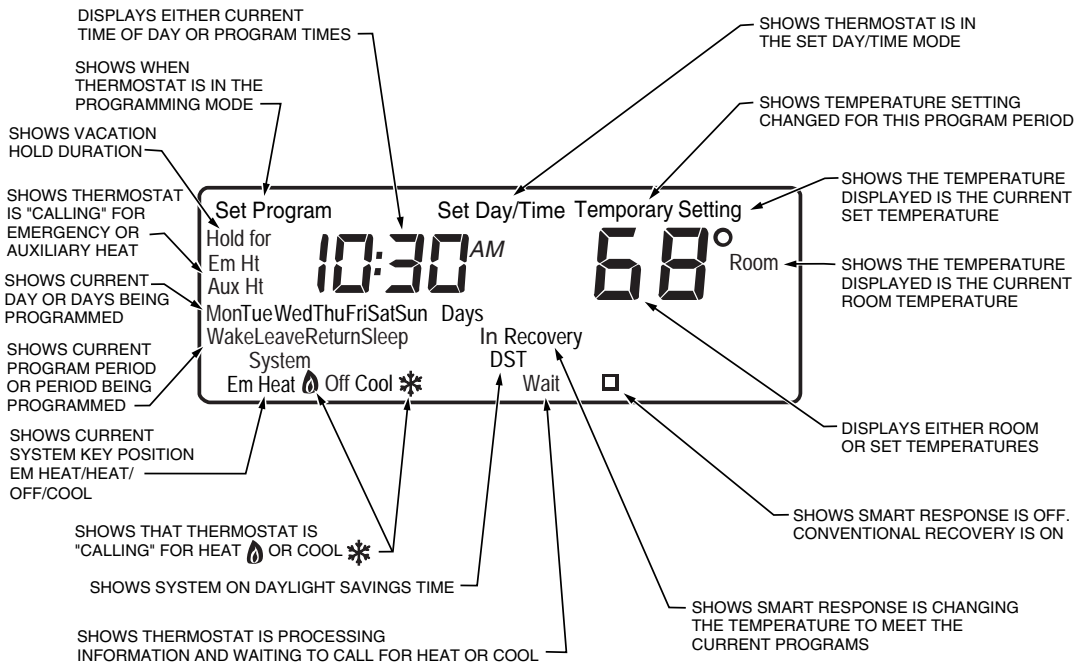

M18756A

# STEP 1. PREPARE FOR INSTALLATION

- ❑ This thermostat is designed to work with multistage heat pumps (heat pumps with Auxiliary and/or Emergency Heat). Check Table 1 in Step 4 to make sure the CT3611 is compatible with your system. If you have compatibility questions, contact Honeywell at [www.honeywell.com/yourhome](http://www.honeywell.com/yourhome) or call the Customer Relations Center at 1-800-468-1502.

## Package Contents

- Thermostat
- Screws and anchors
- Wallplate
- Wiring labels
- Owners manual

## Tools Required

- Screwdriver
- Drill

# STEP 2. REMOVE OLD THERMOSTAT

- ❑ Test your heating and cooling systems to make sure they work properly. If either system does not work, contact your local heating/air-conditioning dealer. To avoid compressor damage, do not operate the cooling system when outdoor temperature is below 50°F (10°C).
- ❑ Turn off power to the system at the furnace or the fuse/circuit breaker panel.
- ❑ Carefully unpack your new thermostat and wallplate. Save package of screws, instructions, and receipt.
- ❑ Remove the cover from the old thermostat. If the cover does not snap off when pulled firmly from the bottom, check for a screw or screws used to lock on the cover.
- ❑ Loosen the screw or screws holding the thermostat to the wallplate and lift the thermostat away.
- ❑ Disconnect the wires from the old thermostat. As you disconnect each wire, attach the enclosed labels with the old terminal designation. Wrap the wires around a pencil as shown to keep them from falling back into the wall.

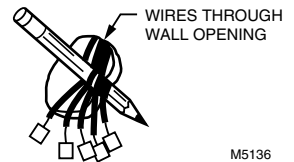

M5136

## STEP 3. MOUNT THERMOSTAT WALLPLATE

- ❑ Separate the wallplate from the thermostat by placing your thumb or fingers between the bottom of the wallplate and the thermostat, and pulling the wallplate up and away from the thermostat. See illustration at right.
- ❑ Position the wallplate on the wall. Level the wallplate for appearance if desired. Use a pencil to mark the two mounting holes that best fit the application.
- ❑ Remove the wallplate from the wall. Drill two 3/16 in. holes in wall (if drywall) as shown. For materials such as plaster or wood, drill 7/32 in. holes where marked. Gently, tap the (provided) anchors into the drilled holes until they are flush with the wall.
- ❑ Reposition the wallplate over the holes. Pull the wires through the wiring opening. Loosely insert mounting screws into each of the holes.
- ❑ Level the wallplate if desired. Thermostat functions properly when not level.
- ❑ Tighten mounting screws.

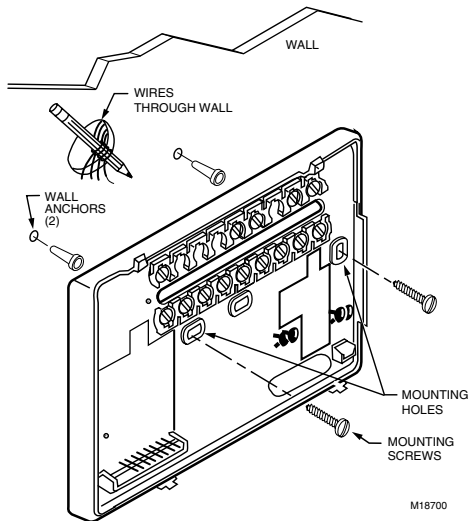
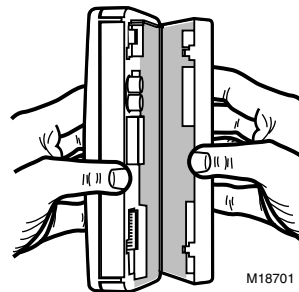

## STEP 4. WIRE WALLPLATE TERMINALS

### IMPORTANT

*All wiring must comply with local codes and ordinances. If unsure about household wiring procedures, call your local heating/air-conditioning contractor.*

Refer to the labels you placed on the wires when you removed the old thermostat (see illustration).

- ❑ Match the letter of your old thermostat wire with the corresponding terminal letter on your new thermostat. Refer to Table 1.
- ❑ For wiring diagrams, if needed, see page 21.
- ❑ Loosen the terminal screws. Slip each wire beneath its matching terminal. Wraparound and straight connections are both acceptable, (see illustration). Tighten the terminals.

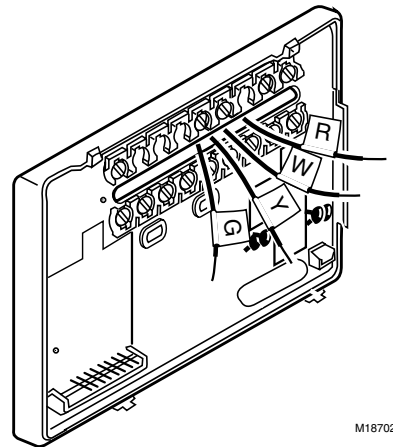
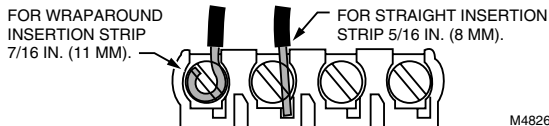

M18702

- ❑ Plug the hole in the wall with insulation to help prevent drafts from adversely affecting thermostat operation.
- ❑ Match the terminals from your old thermostat to the terminals on the CT3611. Find the column from Table 1 that matches your existing thermostat wire terminals to help you match the terminals correctly.

**IMPORTANT**

If you have any wiring questions, contact Honeywell at [www.honeywell.com/yourhome](http://www.honeywell.com/yourhome) or call Honeywell Customer Relations Center, toll-free, 1-800-468-1502.

**Table 1. Terminal Designations on Old and New Thermostats.**

CT3611 <sup>a</sup>	Typical Terminal Designations from the Existing Thermostat			Alternative Terminal Designations					Function Description
				Trane American Standard	Lennox	York Borg Warner	General Electric	Rheem Ruud	
C	C	C or X	C	B	X	B	C or B	X	Common
R	R	R	R	R	V or VR <sup>b</sup>	R	R	R	Power
Y	Y or Y1	Y or Y1	Y or Y1	Y	M	Y	Y	Y or Y1	Compressor
W1 <sup>c</sup>	—	—	—	—	—	—	—	—	Stage 1 heating relay
W2	W or W1	W, W1 or W2	W or W1	W or W1 jumped to U	W1 or Y	W or W2	W or W1	W2	Auxiliary heat relay
G	G	G	G	G	F or G	G	G	G	Fan relay
O <sup>a</sup>	O <sup>a</sup>	O <sup>a</sup>	O <sup>a</sup>	O <sup>a</sup>	R or O <sup>a</sup>	O <sup>a</sup>	O <sup>a</sup>	O <sup>a</sup>	Cooling changeover relay
B <sup>a</sup>	B <sup>a</sup>	B <sup>a</sup>	B <sup>a</sup>	—	—	H	—	—	Heating changeover relay
L	L	L or X	L	F or L	L	F	F or L	L	System monitor
E	E	E	E or X	X2 or E	E	X or E	E or X2	E	Emergency heat relay
—	—	—	—	T <sup>d</sup> or A <sup>d</sup>	A <sup>d</sup>	T <sup>d</sup>	T <sup>d</sup>	—	Tape off, not needed for CT3611

<sup>a</sup> Never attach wires to both the O and B terminals on the CT3611. If the old thermostat had wires on both the O and B terminals, be sure to attach the B wire to the CT3611 C terminal. If another wire is already matched to the C terminal, contact Honeywell.

<sup>b</sup> If the old thermostat had separate wires on both the V and VR terminals, some system modification is required. Call your local heating and cooling contractor for assistance.

<sup>c</sup> If the old thermostat had wires on W1, Y1 and W2 terminals, then remove the CT3611 factory-installed jumper between Y and W1 terminals and match the old W1 to W1, Y1 to Y and W2 to W2.

<sup>d</sup> Use electrical tape to tape off the end of the wire and push the taped end back into the wall wiring hole.



## STEP 5. MOUNT THE THERMOSTAT

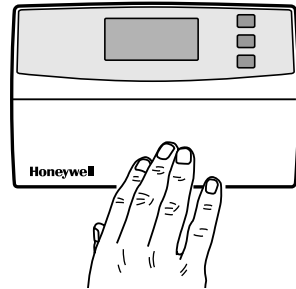
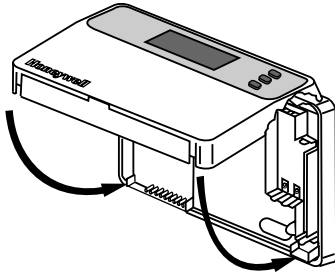

## STEP 6. CUSTOMIZE YOUR THERMOSTAT

Your Honeywell CT3611 thermostat comes preset to the most commonly used settings. The settings are:

- Auxiliary and/or Emergency Heat type.
- Smart Response™ technology on.
- Temperature °F.
- 12-hour clock format.

You can change any or all of these settings.

### **IMPORTANT**

*Always press the keys with your fingertip or a similar blunt tool. Sharp instruments like pens and pencil points can damage the keyboard.*

- Press and hold down **▽**, **△**, and **ⓘ**, simultaneously until the screen shows. You now can change any of these settings.

### Auxiliary Heat Type (Feature Number 5)

Auxiliary Heat options are:

- 3 = Hot water, high efficiency furnace (90% or better).
- 6 = Gas or oil forced air furnace (preset).
- 9 = Electric heat system.

To change your Auxiliary Heat type:

- Press **△** until display shows your Auxiliary Heat type.
- Press Time **△** to move to next feature or **Run Program** to return to main display.

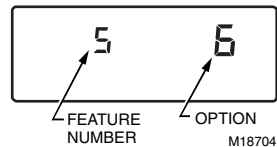

M18704

### Emergency Heat Type (Feature Number 7)

Emergency Heat options are:

- 3 = Hot water, high efficiency furnace (90% or better).
- 6 = Gas or oil forced air furnace.
- 9 = Electric heat system (preset).

To change your Emergency Heat type:

- Press **△** until display shows your Emergency Heat type.
- Press Time **△** to move to next feature or **Run Program** to return to main display.

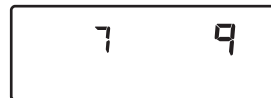

M18705

### Smart Response™ Technology (Feature Number 13)

Smart Response technology options are:

- 0 = Smart Response technology on (preset).
- 1 = Smart Response technology off.

To turn Smart Response technology on or off:

- Press **△** once.
- Press Time **△** to move to next feature or **Run Program** to return to main display.



M13343

NOTE: See Smart Response™ technology (page 20) for information about this feature.

## Temperature Format (Feature Number 14)

Temperature format options are:

- 0 = °F (preset).
- 1 = °C.

To change temperature format:

- Press  once.
- Press Time  to move to next feature or  to return to main display.

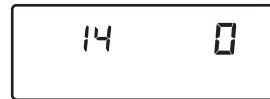



M13344

## Time Format (Feature Number 16)

Time format options are:

- 0 = 12-hour clock (preset).
- 1 = 24-hour clock.

To change time format:

- Press  once.
- Press  to return to main display.



M13345

## Factory Set Function (Feature Number 37)

Do not change this setting.









M13346

# STEP 7. SET THE CLOCK

## Set Current Day and Time



NOTE: On initial power-up, the screen flashes 1:00 pm until you press a key.

- Press .
- Press  until screen shows current day.
- Press Time  or  until screen shows current time. (Tapping the  will advance the time in one hour increments).

- ❑ Press  until "DST" displays if daylight savings time is in effect.
- ❑ Press .

## STEP 8. PROGRAMMING

The keyboard is located behind the thermostat cover. The three most frequently used keys are near the display.

Pressing  displays the current temperature settings. Pressing the  and  keys change the temperature. The thermostat displays day, time, program period, temperature and system settings.

The thermostat displays day, time, program period, temperature, system and fan settings.

There is an individual key for each of the four program periods:





- —The program period when you want the house at a comfortable temperature when you get up and while you get ready for work or school. (This is a higher temperature during the heating season and a lower temperature during the cooling season).
- —The program period you can set for an energy-saving temperature while you are away at work or school. (This is a lower temperature during the heating season and a higher temperature during the cooling season).
- —The program period when you want the house at a comfortable temperature for activities before bedtime. (This is a higher temperature during the heating season and a lower temperature during the cooling season).
- —The program period you can set for an energy-saving temperature while you are sleeping. (This is a lower temperature during the heating season and a higher temperature during the cooling season).

Table 2 can be helpful when planning your schedule of time and temperature settings. The thermostat default settings are shown in parentheses ( ).

**Table 2. Personal Programming Table.**





Period	Default Setting	Monday (Mon)	Tuesday (Tue)	Wednesday (Wed)	Thursday (Thu)	Friday (Fri)	Saturday (Sat)	Sunday (Sun)
Wake	Time (6:00AM)							
	Heat <sup>a</sup> (70°F/21°C)							
	Cool <sup>b</sup> (78°F/25.5°C)							
Leave	Time (8:00AM)							
	Heat <sup>a</sup> (62°F/16.5°C)							
	Cool <sup>b</sup> (85°F/29.5°C)							
Return	Time (6:00PM)							
	Heat <sup>a</sup> (70°F/21°C)							
	Cool <sup>b</sup> (78°F/25.5°C)							
Sleep	Time (10:00PM)							
	Heat <sup>a</sup> (62°F/16.5°C)							
	Cool <sup>b</sup> (82°F/28°C)							

<sup>a</sup> Your heating setpoints cannot be higher than 90°F (32°C) or lower than 40°F (4.5°C).

<sup>b</sup> Your cooling setpoints cannot be higher than 99°F (35°C) or lower than 45°F (7°C).

## Program the First Day

Start by programming the wake time and temperature for one day.

- Press and release .
- Press  until the desired day displays. (Mon, Tue, Wed, Thu, Fri, Sat, Sun)
- Press time  or  until the desired time shows in the display.





NOTE: Program times are in 15 minute intervals. For example, 8:00, 8:15, 8:30.

- ❑ Press  or  until the desired wake temperature displays.

The setpoint temperature range is 40°F to 90°F (7°C to 31°C) for heating and 45°F to 99°F (9°C to 37°C) for cooling.

- ❑ Press  to switch between setpoints.

NOTE: Program times are the same for heating and cooling.







- ❑ Press  or  until the display shows the desired temperature setpoint.
- ❑ Press ,  or  and repeat these steps for each program period. The first day is now programmed.
- ❑ Repeat each step in Program the First Day for the rest of the week.

NOTE: After the first day is programmed, you can copy that day to any other day using procedure in Copy a Day.

- ❑ Press  when the entire week is programmed.

## Copy a Day

Your thermostat can copy program settings from one day to another.

- ❑ Press , ,  or  to enter programming mode.
- ❑ Press  until the display shows the day you want to copy.
- ❑ Press . The display shows.

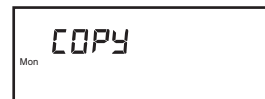

M13327

- ❑ Press  until the display shows the day you want to copy to.

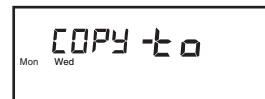

M13328

❑ Press **Copy** to accept the change.

❑ Repeat these steps for each day you want to copy.

NOTE: donE appears for two seconds and then the normal program display appears.



M13329

## Clear a Program Period

NOTE: Wake cannot be cleared.

❑ Press **Leave**, **Return**, or **Sleep** for the program period you want to clear.

❑ Press **Day** until the desired day displays.

❑ Press and hold the **Leave**, **Return**, or **Sleep** for approximately 3 seconds until the time and temperature clear.

❑ Repeat the above steps for each period to be cleared.

❑ Press **Run Program**.

## STEP 9. OPERATING YOUR THERMOSTAT

### Change Temperature Setting Until the Next Program Period (Temporary Change)

❑ Press **▲** or **▼** until the screen shows the desired temperature setting.

NOTE: The temporary temperature setting is displayed for about 3 seconds and then the room temperature is displayed. Temporary appears in the display. The setting cancels when the next program period starts or when

you press **Run Program**.

## Change Temperature Setting Indefinitely (Hold)

- ❑ Move the System switch to the desired position (Heat or Cool).
- ❑ Press **Hold Temp** then **▲** or **▼** to change your setting if desired. (The display changes from showing the setpoint temperature to room temperature after approximately three seconds).
- ❑ To cancel “Hold” press **Run Program**.

## Change the Temperature Setting Until a Designated Day and Period (Vacation Hold)

- ❑ Press **Hold Temp** twice.
- ❑ Press **▲** or **▼** until the display shows the desired temperature setpoint.
- ❑ Press Time **▲** until the desired number of days that you will be away (1 through 255) is displayed.
- ❑ Press **Wake**, **Leave**, **Return** or **Sleep** to select the program period when you want the program to restart.

NOTE: If the Vacation Hold needs to be cancelled before the designated time, press **Run Program** to return to the program.

## Daylight Savings Time Key



This feature allows you to switch between standard time and daylight savings time.

- ❑ Press **Daylight Time** during fall to set the time back one hour.
- ❑ Press **Daylight Time** during the spring to set time forward one hour. DST is displayed when operating on daylight savings time.

NOTE: Pressing the Daylight Time key more than once in a five minute period scrolls you through various time options. For example, one hour earlier or later, with or without DST. Pressing Daylight Time six times in a five minute period returns you to your original setting.



## Usage Key

- ❑ Press  once to display the hours and minutes that the heating or cooling system has been operating for the current day.
- ❑ Press  a second time to display the system operating time for the previous day (midnight to midnight).
- ❑ Press  a third time to display the system operating time since the last time the usage function was cleared.

NOTE: Press  for three seconds to clear the usage function.

## STEP 10. SET THE FAN AND SYSTEM SWITCHES

First set the fan switch.

**Fan On:** The fan runs continuously. Use for improved air circulation or for more efficient central air cleaning. (In a heat-only system, fan runs continuously only if fan relay is connected to the G thermostat terminal).

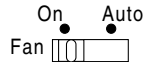

**Fan Auto:** Normal setting for most homes. The equipment controls the fan operation.

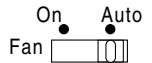

Then set the system switch.

**Heat:** The thermostat controls your heating system.

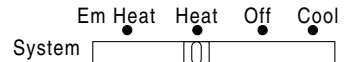

**Off:** Both the heating and cooling systems are off.

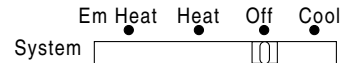

**Cool:** The thermostat controls your cooling system.

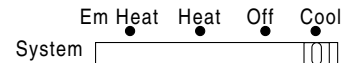

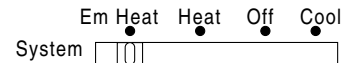

**Em Heat:** Emergency heat or Auxiliary heat control to setpoint. The heat pump compressor is off.



# IF YOU HAVE A PROBLEM

**Table 3. Solution Guide.**

If...	Then...
Display does not appear.	<ul style="list-style-type: none"> <li>• Make sure the thermostat is mounted and latched on the wall plate. Mount and latch the thermostat on the wallplate if it is not.</li> <li>• Make sure terminal C is connected to the system transformer common.</li> <li>• Make sure circuit breaker is not tripped—reset the circuit breaker.</li> <li>• Make sure the wiring between the thermostat and HVAC equipment has no broken wires—replace any broken wires.</li> </ul>
Temperature settings will not change (example; cannot set the heating higher or the cooling lower).	<ul style="list-style-type: none"> <li>• Make sure the temperature setpoints are: 40 to 90°F (4.5 to 32°C) for heating. 45 to 99°F (7 to 35°C) for cooling.</li> </ul>
Heating does not come on.	<ul style="list-style-type: none"> <li>• Make sure the heating setpoint is above the room temperature.</li> <li>• Make sure the circuit breaker is not tripped, and reset it if necessary.</li> <li>• Make sure the power switch at the equipment is in the On position, and set it to On if it is in the Off position.</li> <li>• Wait five minutes for the system to respond.</li> <li>• Set the system switch to Heat.</li> </ul>
Cooling does not come on.	<ul style="list-style-type: none"> <li>• Make sure the cooling setpoint is below the room temperature.</li> <li>• Make sure the circuit breaker is not tripped, and reset it if necessary.</li> <li>• Make sure the system switch at the air conditioner is in the On position, and set it to On if it is in the Off position.</li> <li>• Wait five minutes for the system to respond.</li> <li>• Set the system switch to Cool.</li> </ul>
System on indicator(  = heat,  = cool) is lit, but no warm or cool air is coming from the registers.	Wait five minutes after seeing the flame or snowflake and check the registers again. If no there is no hot or cool air coming from the registers, refer to Heating does not come on or Cooling does not come on. If all of this has been checked, contact your local heating and cooling contractor.

**Table 3. Solution Guide.**

<b>If...</b>	<b>Then...</b>
Display flashes during programming.	The temperature setting limit has been reached. The heating setting range is 40°F to 90°F (4.5°C to 32°C). The cooling setting range is 45°F to 99°F (7°C to 35°C).
Temperature change occurs at the wrong times.	<ol style="list-style-type: none"> <li>1. Check the program times for the period in question.</li> <li>2. Make sure the AM and PM settings are correct.</li> <li>3. Make sure the current time and day settings are correct.</li> <li>4. Reprogram any incorrect settings.</li> </ol> <p>NOTE: If your thermostat is set for Smart Response™ technology, the start times occur before your programmed comfort periods.</p>
Display shows Wait.	The thermostat is in a compressor protection delay. Wait five minutes and check the registers again.
LED is on.	If a separate wire is hooked to the L terminal it can be connected to a system monitor. If so, the light being on indicates a problem with the heat pump. Contact your local heating and cooling contractor.

### Toll-Free Customer Assistance

Please read and follow the provided instructions for this thermostat. For additional information, go to [www.honeywell.com/yourhome](http://www.honeywell.com/yourhome) or call the Honeywell Customer Relations Center at 1-800-468-1502. The Center hours are Monday through Friday, 7:00AM to 5:30PM Central Time.

Before calling, please have the following information available:

- Thermostat model number. (Located on back of thermostat).
- Thermostat date code. (Located below model number).
- Type of heating/cooling system (for example, hot water, warm air, oil, or gas).
- Location and number of wires connected to the thermostat.

# SMART RESPONSE™ TECHNOLOGY

Your CT3611 is actually a small computer. The Smart Response™ technology calculates the correct time of day to turn on your heating or cooling system. Smart Response technology considers the following information.

- Air temperature.
- Wall temperature.
- The time of day when you want the comfort temperature established.

When the thermostat activates Smart Response technology, the thermostat displays **In Recovery**, changes the setpoint, and turns on the system.

- Your CT3611 thermostat learns from experience. Each day it checks how closely it hit the recovery target and then adjusts the next day's recovery start time accordingly.
- It takes a few days after installation for the thermostat to adjust to the local weather, your lifestyle, the construction of your home, and your heating/cooling system.
- You can turn off Smart Response technology by selecting Conventional Recovery. Honeywell does not recommend this because the auxiliary heat comes on once the program time begins and run continuously until the setpoint is reached. See Step 6. Customize Your Thermostat.

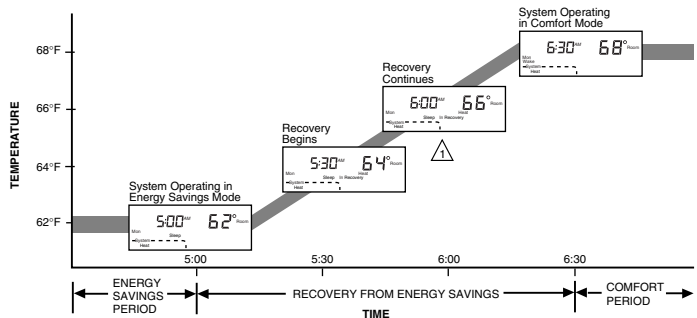

THE THERMOSTAT USES THE SAME SCHEME TO RETURN TO LOWER COMFORT TEMPERATURE DURING THE COOLING SEASON.

⚠ IF **In Recovery** IS DISPLAYED, PRESS  TO SEE THE COMFORT SETPOINT.

M18591

# WIRING DIAGRAMS

See Table 1 on page 8 for additional wiring assistance.

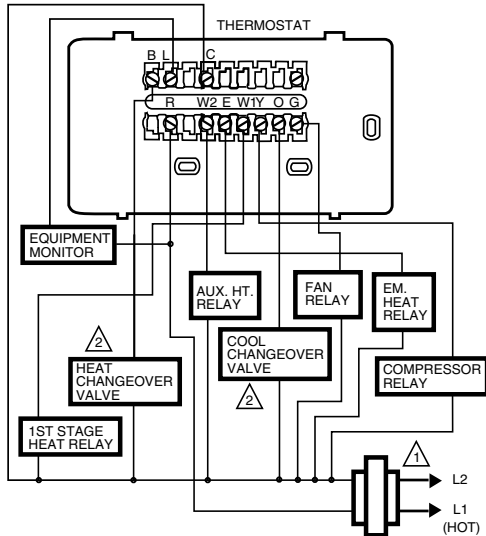

- ⚠️ POWER SUPPLY. PROVIDE DISCONNECT MEANS AND OVERLOAD PROTECTION AS REQUIRED.
- ⚠️ NEVER ATTACH WIRES TO BOTH THE O AND B TERMINALS. SEE WIRE WALLPLATE TERMINALS SECTION FOR MORE DETAILS. M15110B

**Typical hookup of CT3611 with isolated stage-one heating and cooling connections.**

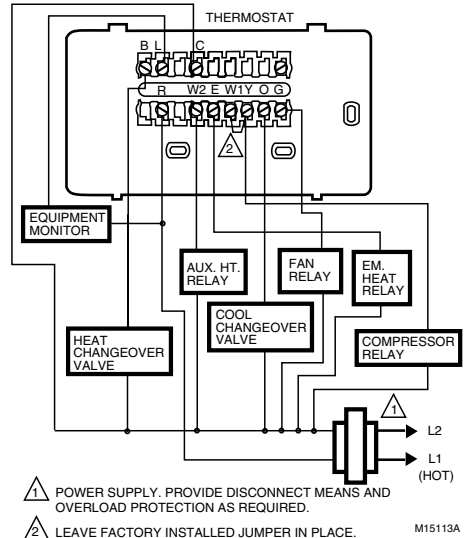

- ⚠️ POWER SUPPLY. PROVIDE DISCONNECT MEANS AND OVERLOAD PROTECTION AS REQUIRED.
- ⚠️ LEAVE FACTORY INSTALLED JUMPER IN PLACE. M15113A

**Typical hookup of CT3611.**

## Notice:

This thermostat is a Class B digital apparatus that complies with Canadian Radio Interference Regulations, CRC c. 1374.

## Limited One-Year Warranty

Honeywell warrants this product, excluding battery, to be free from defects in the workmanship or materials, under normal use and service, for a period of one (1) year from the date of purchase by the consumer. If, at any time during the warranty period, the product is defective or malfunctions, Honeywell shall repair or replace it (at Honeywells option) within a reasonable period of time.

If the product is defective,

- (i) return it, with a bill of sale or other dated proof of purchase, to the retailer from which you purchased it, or
- (ii) package it carefully, along with proof of purchase (including date of purchase) and a short description of the malfunction, and mail it, postage prepaid, to the following address:

Honeywell USA

Dock 4 — MN10-3860

1885 Douglas Drive North

Golden Valley, MN 55422-3992

Honeywell Canada:

Honeywell Limited/Honeywell Limitée

35 Dynamic Drive

Scarborough, Ontario M1V 4Z9

This warranty does not cover removal or reinstallation costs. This warranty shall not apply if it is shown by Honeywell that the defect or malfunction was caused by damage which occurred while the product was in the possession of a consumer.

Honeywells sole responsibility shall be to repair or replace the product within the terms stated above. HONEYWELL SHALL NOT BE LIABLE FOR ANY LOSS OR DAMAGE OF ANY KIND, INCLUDING ANY INCIDENTAL OR CONSEQUENTIAL DAMAGES RESULTING, DIRECTLY OR INDIRECTLY FROM ANY BREACH OF ANY WARRANTY, EXPRESS OR IMPLIED, OR ANY OTHER FAILURE OF THIS PRODUCT. Some states do not allow the exclusion or limitation of incidental or consequential damages, so this limitation may not apply to you.

THIS WARRANTY IS THE ONLY EXPRESS WARRANTY HONEYWELL MAKES ON THIS PRODUCT. THE DURATION OF ANY IMPLIED WARRANTIES, INCLUDING THE WARRANTIES OF MERCHANTABILITY AND FITNESS FOR A PARTICULAR PURPOSE, IS HEREBY LIMITED TO THE ONE YEAR DURATION OF THIS WARRANTY. Some states do not allow limitations on how long an implied warranty lasts, so the above limitation may not apply to you.

This warranty gives you specific legal rights, and you may have other rights which vary from state to state.

If you have any questions concerning this warranty, please write our Customer Relations Center, Honeywell Inc., 1885 Douglas Dr. N., Golden Valley, MN 55422-3992, or call 1-800-468-1502, Monday-Friday, 7:00 a.m. to 5:30 p.m., Central time. In Canada, write Retail Products ON30 Honeywell Limited/Honeywell Limitée, 35 Dynamic Drive, Scarborough, Ontario M1V 4Z9.

# Honeywell

---

**Home and Building Control**

Honeywell  
1985 Douglas Drive North  
Golden Valley, MN 55422

**Home and Building Control**

Honeywell Limited-Honeywell Limitée  
35 Dynamic Drive  
Scarborough, Ontario  
M1V 4Z9

69-1081—3 J.H. Rev. 11-01



Printed in U.S.A. on recycled  
paper containing at least 10%  
post-consumer paper fibers.

[www.honeywell.com/yourhome](http://www.honeywell.com/yourhome)