

Honeywell

Clock Thermostat Fuel Saver

- Heat Only—CT1800
- Heat/Cool—CT1801
- Central Heat/Cool or Single Stage Heat Pump without Auxiliary Heat—CT1802

Heating-Only Thermostat and Wallplate or a Heating/Cooling Thermostat and Subbase
Models CT1800, CT1801, CT1802

OWNER'S MANUAL



69-0395-2

Welcome to the world of energy savings with your new Honeywell Fuel Saver Thermostat. The Honeywell name is your assurance of accurate control and reliable operation for years to come.

Your new thermostat will automatically control the temperature in your home to provide a high level of comfort plus energy savings when programmed according to the instructions in this manual.

Recycling Notice



This control contains mercury in a sealed tube. Do *not* place control in the trash at the end of its useful life.

If this control is replacing a control that contains mercury in a sealed tube, do *not* place your old control in the trash.

Contact your local waste management authority for instructions regarding recycling and the proper disposal of this control, or of an old control containing mercury in a sealed tube.

Table of Contents

	PAGE
Features Of Your Thermostat	5
Reviewing Your Family Schedule	8
Setting The Temperature	9
Setting Subbase Switches	10
Inserting Clock Batteries	11
Setting The Clock	12
Programming	13
Troubleshooting	18
Servicing The Thermostat	22
System On-Time Adjustment	22
Thermometer Adjustment	23
Limited One-Year Warranty	25

Features Of Your Thermostat

- ① **FLIP-UP COVER.** Lift it up to set clock for energy savings and normal temperature periods.
- ② **THERMOSTAT COVER.** Lift up and remove to adjust heat anticipator or install batteries.
- ③ **THERMOMETER.** Provides accurate room temperature reading.
- ④ **CLOCK.** This clock provides a 24-hour slotted dial to hold the programming pins.
- ⑤ **CLOCK HANDS.** Turn minute hand clockwise  to match the correct AM or PM time to the time indicator.
- ⑥ **TIME INDICATOR.** Arrowhead indicates time for 24-hour dial.

- ⑦ **PROGRAM INDEX WHEEL.** Controls high and low temperature at specific time of day as set by program pins. Can be moved to temporarily override a schedule.

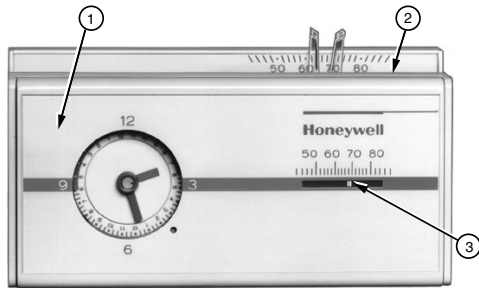

M9653

- ⑧ **TEMPERATURE SETTING LEVERS.** Left (blue mark) controls the low temperature; right (red mark) controls the high temperature.
- ⑨ **PROGRAM PINS.** Must be inserted into 24-hour clock dial slots to control program index wheel.
- ⑩ **PIN SLOTS.** Located on 24-hour dial at ten-minute intervals for program pin insertion.
- ⑪ **HEAT ANTICIPATOR SCALEPLATE.** Calibrated to match the heating system current draw in amperes.
- ⑫ **ANTICIPATOR SETTING LEVER.** Must be adjusted to match the heating system primary control current.
- ⑬ **BULB AND BIMETAL ELEMENT (2).** Provide automatic temperature control by switching on and off the heating or cooling system.

- ⑭ **AAA ALKALINE BATTERIES (2).** Included to provide power to the clock.

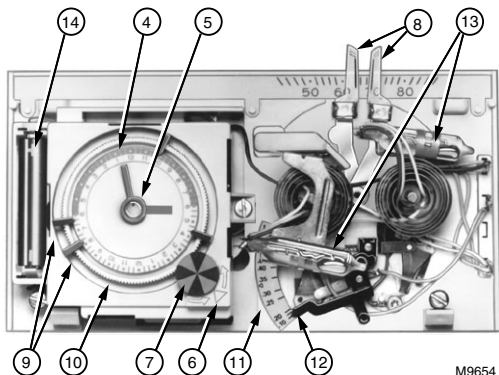

- 15 WALLPLATE. Provides mounting base and wiring connections for heating-only thermostat.

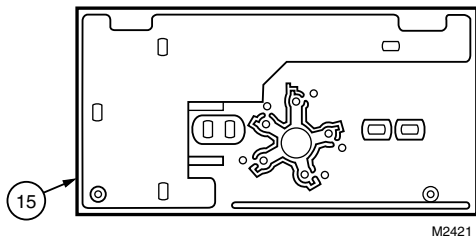

- 16 SUBBASE. Provides mounting base, wiring connections and manual switching control for heating/cooling thermostat.

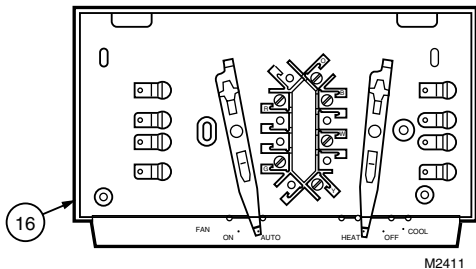

Reviewing Your Family Schedule

Write the answers to the following questions in the spaces provided to determine the program that fits your family schedule.

	SUMMER	WINTER
What comfort temperature would you like to maintain?	_____	_____
What energy savings temperature would you like to maintain?	_____	_____
What time does the first person get up in the morning?	_____	_____
Is anyone home all day?	_____	_____
What time does the last person leave in the morning?	_____	_____
What time does the first person return home in the evening?	_____	_____
What time does the last person go to bed?	_____	_____

Setting The Temperature

For Heating:

Set the left lever (blue mark) to the energy savings temperature you want when you are sleeping or your home is unoccupied.

Set the right lever (red mark) to the temperature you want for normal comfort periods.

NOTE: You may override the time program by setting both the red and blue levers to the same temperature setpoint.

For Cooling (not applicable on heating-only model):

Set the left lever (blue mark) to the temperature you want for normal comfort periods.

Set the right lever (red mark) to the energy savings temperature you want when you are sleeping or your home is unoccupied. See Fig. 1.

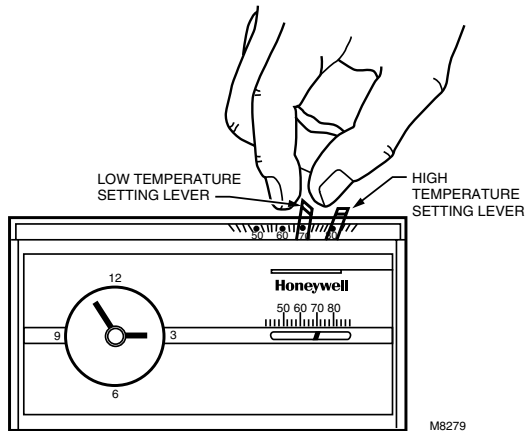

Fig. 1—Setting high and low temperature levers.

Setting Subbase Switches (if applicable)

The subbase system switch controls system operation as follows:

HEAT: Heating system is controlled by the thermostat. Cooling system is off.

COOL: Cooling system is controlled by the thermostat. Heating system is off.

OFF: Both the heating and cooling systems are off. If the fan switch is at the AUTO position, the fan is also off.

AUTO: In a cooling only application, only cooling operates. In a heating only application, only heating operates.

The subbase fan switch controls fan operation as follows:

ON: Fan operates continuously.

AUTO: Fan operates with cooling equipment as controlled by the thermostat or with the heating equipment as controlled by the plenum fan switch. In electric heat, heat pump, and fan coil systems, the fan is controlled by the thermostat in heating and cooling.

To switch positions, use thumb or index finger to slide lever to desired position. Switch lever must stop in detent over desired function indicator mark for proper circuit operation.

Inserting Clock Batteries

Power is supplied to the clock by two AAA alkaline batteries (included). Install batteries in thermostat as shown in Fig. 2. Once a year, or when batteries are dead, replace with two new AAA alkaline batteries. We recommend Energizer® batteries. The thermostat itself will operate without batteries, but will not operate as a fuel saver.

BATTERY LOCATION
FOR (2) AAA BATTERIES;
INSTALL WITH POSITIVE
ENDS UP

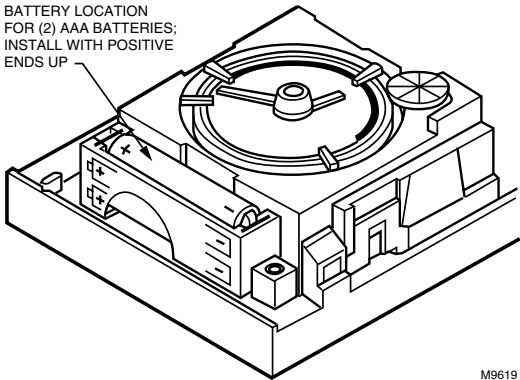

M9619

Fig. 2—Inserting clock batteries.

Setting The Clock

Lift thermostat flip-up cover and you'll find the 24-hour program dial, slotted in 10-minute increments. Adjust the clock to the current time by moving the minute hand carefully in the clockwise  direction. Do *not* reverse the minute hand.

When time is correctly set, the Time Indicator Arrow (see Fig. 3) will point to the correct time and corresponding daytime (light) or nighttime (dark) band of the program dial.

EXAMPLE: For 11 PM, the time indicator arrow will point directly to the dark band. For 11 AM, the arrow will point to the light band on the dial.

Daylight Saving Time

When daylight saving time starts, move the minute hand carefully in a clockwise 

direction one hour. When daylight saving time ends, move the minute hand carefully in a clockwise  direction 23 hours. Do *not* reverse the minute hand, or damage to the clock mechanism may occur.

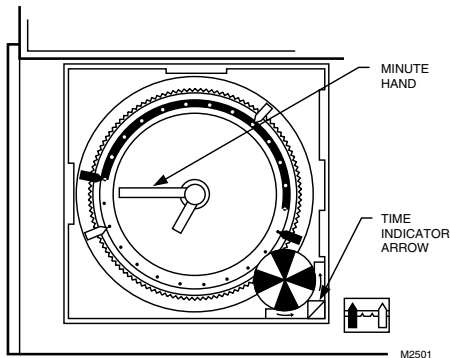

Fig. 3—Setting the clock.

Programming

You can program your thermostat to automatically lower and raise the temperature one or more times every 24 hours.

Refer to the energy savings chart on the back cover for typical heating and cooling savings with your new thermostat.

Before setting your program:

Lift thermostat flip-up cover and you'll find the 24-hour program dial. The slots on the program dial (Fig. 4) are for the program pins, which can be inserted at 10-minute intervals.

Three red and three blue program pins are included with your thermostat. The red pins start the high-temperature period; the blue pins start the low-temperature period. A heating program is preprogrammed. A red pin is inserted at 6:00 AM

for high temperature (comfort period); a blue pin is inserted at 10:00 PM for low temperature (energy saving period).

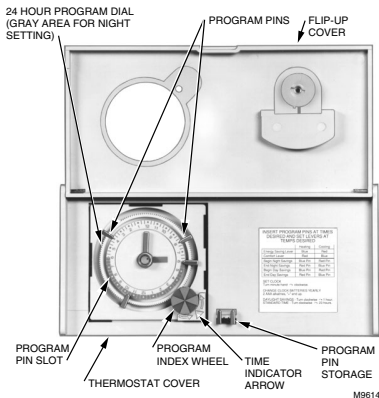

Fig. 4—Program components.

Two additional sets of pins are located in the program pin storage area. You can set up to six temperature changes with the pins supplied. We recommend at least five hours for each energy saving period.

To change the pins or add a new energy savings period—

- To insert a pin, push it straight into the selected notch on the program dial until it is completely seated.
- To remove a pin, press against program dial and pull the pin straight out. Do *not* attempt to change a pin if it is engaged with the program index wheel.
- On heating/cooling systems, you must reset the pins when the seasons change. You will also probably want to change the lever positions.

Setting the heating program:

Decide when you want the temperature to reach the comfort level. Find the notch on the dial that is one-half hour before this time and insert a red pin. The half-hour head start gives the furnace time to heat the house before you wake up or arrive home.

		WINTER			SUMMER 		
		TEMPERATURE		PROGRAM PIN IN CONTROL	TEMPERATURE		PROGRAM PIN IN CONTROL
		°F	°C		°F	°C	
NIGHT ENERGY SAVING PERIOD	BEGINS 10:00 PM	58	14	BLUE	80	27	RED
	ENDS 6:00 AM	68	20	RED	75	24	BLUE
DAY ENERGY SAVING PERIOD	BEGINS 7:30 AM	58	14	BLUE	80	27	RED
	ENDS 4:00 PM	68	20	RED	75	24	BLUE



NOT APPLICABLE ON HEATING-ONLY MODEL.

M8677

Fig. 5—Programming examples.

Decide when you want the energy savings period to start and insert a *blue* pin at the notch that corresponds to this time. After the blue pin engages, the furnace will be off until room temperature drops to the energy savings setpoint.

You can set both a day and a night program. See Fig. 5 for program examples.

Setting the cooling program (not applicable on heating-only model):

Decide when you want the temperature to reach the comfort level. Find the notch on the dial that is one-half hour before this time and insert a *blue* pin. The half-hour head start gives the air conditioner time to cool the house before you wake up or arrive home.

Decide when you want the energy savings period to start and insert a red pin at the notch that corresponds to this time. After the red pin engages, the air conditioner will be off until room temperature rises to the energy savings setpoint.

Temporarily changing the program

You may temporarily raise or lower the temperature if you come home early, stay up late, plan to be out for the evening, leave on vacation, etc. You can make a temporary change one of two ways—move the program index wheel or push the setting levers together.

A move of the program index wheel will change the program just until the next regularly scheduled change is due.

- Lift the thermostat cover.
- Move the program index wheel counter-clockwise ↺ so the time indicator arrow points to the desired color on the dial.

EXAMPLE: If you are currently at the high temperature period and want to switch to the low temperature period, move the wheel from red to blue. If you are currently at the low temperature period and want to switch

to the high temperature period, move the wheel from blue to red. The change will be in effect until the next regularly scheduled change.

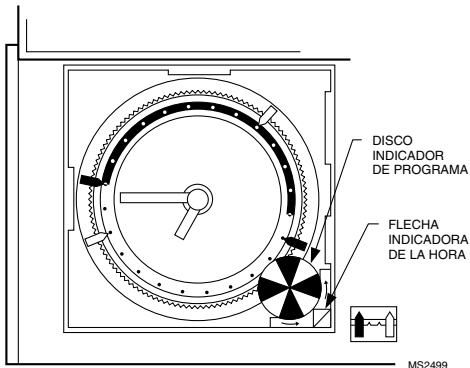

Pushing the setting levers together will hold a particular temperature until you change the levers back. This method is recommended for a long-term absence.

- Simply push both levers to the temperature you wish for system control. This temperature will stay in effect until you change the levers back.

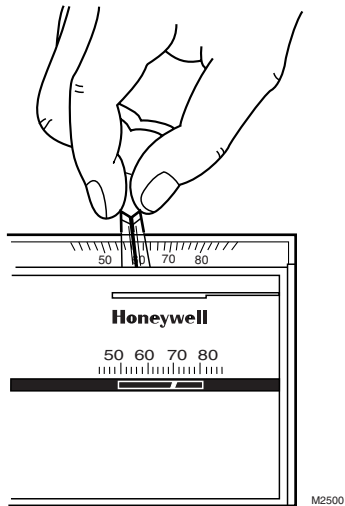

Troubleshooting



Your Honeywell thermostat requires little or no attention. Most problems can generally be traced to the following:

Problem	Check	Action
No heat.	— system switch. May be in OFF or COOL position. 	Move system switch to HEAT position.
	— fuse or circuit breaker.	If blown or tripped, replace fuse or reset breaker.
	— furnace power switch. May be OFF.	Move switch to ON.
	— pilot flame (where applicable). May be out.	Relight pilot flame per furnace manufacturer instructions.
	— RH and W thermostat connections.	Turn Off power to furnace. Check for correct terminal hookups. Repair any frayed or broken wires. Firmly tighten all terminal screws.

(continued)

 Not applicable on heating-only model.

Troubleshooting *(continued)*

Problem	Check	Action
No heat (continued).	— other.	Contact a qualified service technician for assistance.
Energy savings temperature program 12 hours off.	— program dial for proper day or night phase.	Turn clock ahead 12 hours Move minute hand clockwise  only.
Rooms do not warm up at programmed time.	— clock program for heating system. May need more time to warm up rooms.	Move red pin one-half hour earlier on the program dial.
Temperature change occurs at the wrong time.	— program pins for correct time locations.	Relocate pins to desired settings.
Room temperatures are not correct.	— positions of thermostat setpoint levers.	Reset to desired temperatures.
	— position of subbase system switch. 	Move to desired operating position.

(continued)

 Not applicable on heating-only model.

Troubleshooting *(continued)*

Problem	Check	Action
Heat-on time too short.	— anticipator setting. (See Fig. 6 for anticipator location.)	Increase anticipator setting by 0.05. Observe heating system operation.
Heat-on time too long.	— anticipator setting. (See Fig. 6 for anticipator location.)	Decrease anticipator setting by 0.05. Observe heating system operation.
No cooling. 	— system switch. May be in OFF or HEAT position.	Move switch to COOL position.
	— fuse or circuit breaker.	If fuse is blown or breaker tripped, replace or reset.
	— condenser switch position. Located outdoors and may be turned Off.	Move to ON position.
	— Y, G, RC thermostat connections.	Turn Off power to cooling system. Check for correct terminal hookups. Repair any frayed or broken wires. Firmly tighten all terminal screws.

(continued)

 Not applicable on heating-only model.

Troubleshooting *(continued)*

Problem	Check	Action
No cooling (continued).	— other.	Contact a qualified service technician for assistance.
Clock does not run.	— batteries may not have been installed.	Install as shown in Fig. 2.
	— batteries may need replacement.	Replace with two new AAA alkaline batteries as described in Inserting Clock Batteries section.
Thermostat setting and thermometer reading disagree.	— level position of thermostat.	Reinstall thermostat wallplate or subbase. Use a spirit level.
	— area around thermostat for drafts or radiant heat.	Thermostat should be about 5 ft (1.5m) above floor on an inside wall. Contact qualified service technician for change of location.
	— calibration of thermometer.	See Thermometer Adjustment section.

If you have questions regarding your Honeywell Fuel Saver Thermostat please visit our web site at www.honeywell.com/yourhome, or call the customer information line at 1-800-468-1502.

Servicing The Thermostat System On-Time Adjustment

If the thermostat seems to cycle the heating system too fast or too slow, adjust the heating system on-time by moving the anticipator setting lever one indicator mark at a time (Fig. 6). A higher setting will increase heating system on-time length; a lower setting will decrease heating system on-time length. Observe the heating system operation after each adjustment.

The heat anticipator must be correctly set. An incorrect setting can result in room temperature swings or burn out the anticipator, which would void the thermostat warranty.

IMPORTANT: *Most hot water systems require a setting of 1.3 times the valve current rating.*

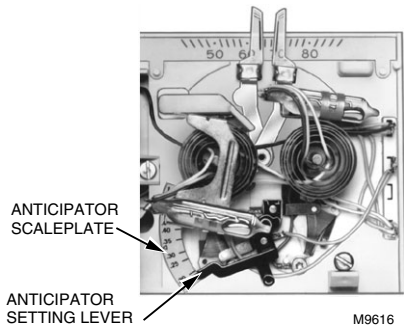

Fig. 6—Heat anticipator setting.

Thermometer Adjustment

The thermometer has been accurately calibrated at the factory and should only need adjustment if it has been dropped or mishandled.

If the setpoint lever and the thermometer reading do not agree, follow the procedure below.

- Remove thermostat cover and open the flip-up cover.
- Set the thermostat cover on a table near a thermometer of known accuracy.
- Allow at least five minutes for the cover thermometer to sense the area temperature; then compare the readings. Be careful not to touch the thermometer or breathe on it.
- If the readings are the same, replace the cover and put the system into operation.

- If the readings are different, insert a small screwdriver in the thermometer slot shown in Fig. 7 and turn it until both thermometers read the same.
- Replace thermostat cover and put the system into operation.

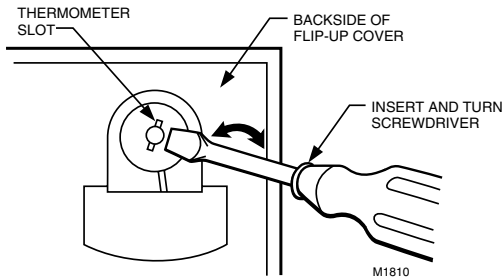

Fig. 7—Thermometer adjustment.

Toll-free Consumer Service

For all questions concerning this thermostat, please read and follow the instructions. If you have questions regarding your Honeywell Fuel Saver Thermostat please visit our web site at www.honeywell.com/yourhome, or call the customer information line at 1-800-468-1502.

Before you call, please have the following information available: thermostat model number and date code, kind of heating/cooling system (i.e., hot water, warm air, oil, gas, etc.) and number of wires connected to the thermostat.

Limited One-Year Warranty

Honeywell warrants this product, excluding battery, to be free from defects in the workmanship or materials, under normal use and service, for a period of one (1) year from the date of purchase by the consumer. If, at any time during the warranty period, the product is defective or malfunctions, Honeywell shall repair or replace it (at Honeywell's option) within a reasonable period of time. If the product is defective:

- (i) return it, with a bill of sale or other dated proof of purchase, to the retailer from which you purchased it, or
- (ii) package it carefully, along with proof of purchase (including date of purchase) and a short description of the malfunction and mail it, postage prepaid, to the following address:

in United States—Honeywell Return Goods
Dock 4 MN10-3860
1885 Douglas Drive North
Golden Valley, MN 55422

in Canada—Honeywell Limited/Honeywell Limitée
35 Dynamic Drive
Scarborough, Ontario M1V 4Z9

This warranty does not cover removal or reinstallation costs. This warranty shall not apply if it is shown by Honeywell that the defect or malfunction was caused by damage which occurred while the product was in the possession of a consumer.

Honeywell's sole responsibility shall be to repair or replace the product within the terms stated above. HONEYWELL SHALL NOT BE LIABLE FOR ANY LOSS OR DAMAGE OF ANY KIND INCLUDING ANY INCIDENTAL OR CONSEQUENTIAL DAMAGES RESULTING, DIRECTLY OR INDIRECTLY FROM ANY BREACH OF ANY WARRANTY, EXPRESS OR IMPLIED OR ANY OTHER FAILURE OF THIS PRODUCT. Some states do not allow the exclusion or limitation of incidental or consequential damages, so this limitation may not apply to you.

THIS WARRANTY IS THE ONLY EXPRESS WARRANTY HONEYWELL MAKES ON THIS PRODUCT. THE DURATION OF ANY IMPLIED WARRANTIES INCLUDING THE WARRANTIES OF MERCHANTABILITY AND FITNESS FOR A PARTICULAR PURPOSE, IS HEREBY LIMITED TO THE ONE YEAR DURATION OF THIS WARRANTY. Some states do not allow limitations on how long an implied warranty lasts, so the above limitation may not apply to you. This warranty gives you specific legal rights, and you may have other rights which vary from state to state.

If you have any questions concerning this warranty, please write our Customer Assistance Center: Honeywell, Customer Assistance MN10-1461, 1885 Douglas Drive North, Golden Valley, MN 55422-4386. In Canada, write: Retail Products ON15 -ZH Honeywell Limited/Honeywell Limitée, 35 Dynamic Drive, Scarborough, Ontario M1V 4Z9.

TYPICAL ENERGY SAVINGS FOR REPRESENTATIVE CITIES IN THE U.S. AND CANADA

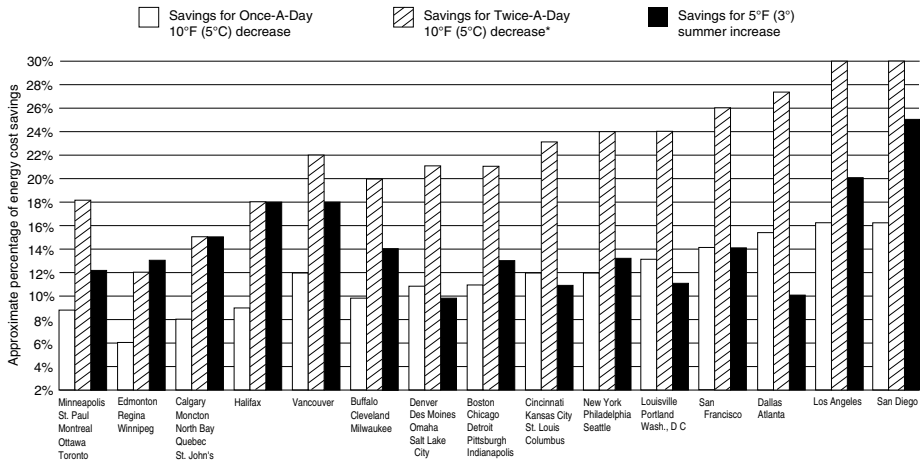

*Based on 10°F (5°C) decrease—(5°F (3°C) decrease gives approximately 55 percent of these savings).

M2416A

Honeywell

Home and Building Control

Honeywell Inc.

1985 Douglas Drive North
Golden Valley, MN 55422

Home and Building Control

Honeywell Limited—Honeywell Limitée

155 Gordon Baker Road
North York, Ontario
M2H 2C9

Helping You Control Your World

www.honeywell.com/yourhome