



HEATING & COOLING

HEATING & COOLING SUBMITTAL TSTATCCPRH01-B

THERMIDISTAT™ CONTROL

The Carrier electronic Thermidistat™ Control is a programmable/non-programmable product. These units feature non-mercury based electronic controls built into a subtle, slim plastic enclosure. They require no battery backup. Outdoor temperature sensor included. The Thermidistat Control can be used with all equipment types, including dual fuel applications.

Clean Design—Features soft, responsive buttons and an easy-to-read backlit Liquid Crystal Display (LCD).

Accurate, Reliable Temperature Control—LCD shows current room temperature at all times, and desired temperature prompts upon demand.

Auto Changeover—Switches system operation automatically when both heating and cooling are needed on the same day. It can be disabled if not necessary in certain areas of the country.

Outdoor Temperature Display—Allows a check of the temperature outside before leaving home.

Clean-Filter Indicator—Tells when it is time to clean the system's filter.

Battery Free—Non-volatile RAM chip requires no battery backup. Program is retained in memory so reprogramming is not required after power loss.

Equipment on Indicator—When the cooling system is operating, the word COOL preceded by a small triangle is displayed below the cooling set point. When the heating equipment is operating, the word HEAT preceded by a small triangle is displayed below the heating set point. If the equipment turn on is being delayed, the triangle and the word will flash.

Comfort and Energy Savings—Seven day programming, with 4 temperature changes provided per day, means comfort when the family is at home and savings through reduced energy usage when the family is away or asleep.

Easy to Use—Simple instructions are located inside the door.

Duplicate Programming—Copy the comfort schedule from one day to the next using the copy previous day function.

Override Capability—Hold function allows the regular schedule to be by-passed with a temporary setting.

Smart Recovery—Provides consistent heating right on time as it gradually adjusts indoor temperatures before a scheduled change.

Room Temperature Offset—Room temperature may be offset by up to 5°F in either direction to accommodate end user's needs.

Low Ambient Cooling Lockout—An option to allow or prevent cooling operation below an outdoor temperature of 55°F.

Dual Fuel Compatible—Can be configured to control 1- or 2-stage heat pump with gas furnace as auxiliary back up.

Auxiliary Heat Lockout Setting—This option prevents auxiliary heat from coming on above a selected outdoor air temperature when configured as a heat pump thermostat using the outdoor air sensor. Or, if using in a dual fuel application this option prevents auxiliary/gas heat from coming on above a selected outdoor air temperature.

Multiple Staging—Can be configured to control single- or two-stage equipment.

Timeguard—Equipment protection.

Perfect Complement—Completes your Carrier total comfort system needs.

Enhanced Comfort—Allows the homeowner to accurately maintain the desired temperature and humidity settings in the home. By combining the functions of a programmable/non-programmable thermostat and a humidistat, the Thermidistat Control provides temperature control, humidity control and dehumidification.

Humidity Control—The Thermidistat Control accurately controls humidity. It controls humidification during heating and dehumidification during cooling.

Automatic Humidity Adjustment—When used with the outdoor temperature sensor, the Thermidistat Control automatically adjusts the humidify setting, reducing excess condensation from forming on the windows.

Vacation Mode—With a single touch of a button, vacation mode adjusts all comfort levels for optimum efficiency while the home is unoccupied – or restores the settings to normal upon return.

PHYSICAL DIMENSION PRINT

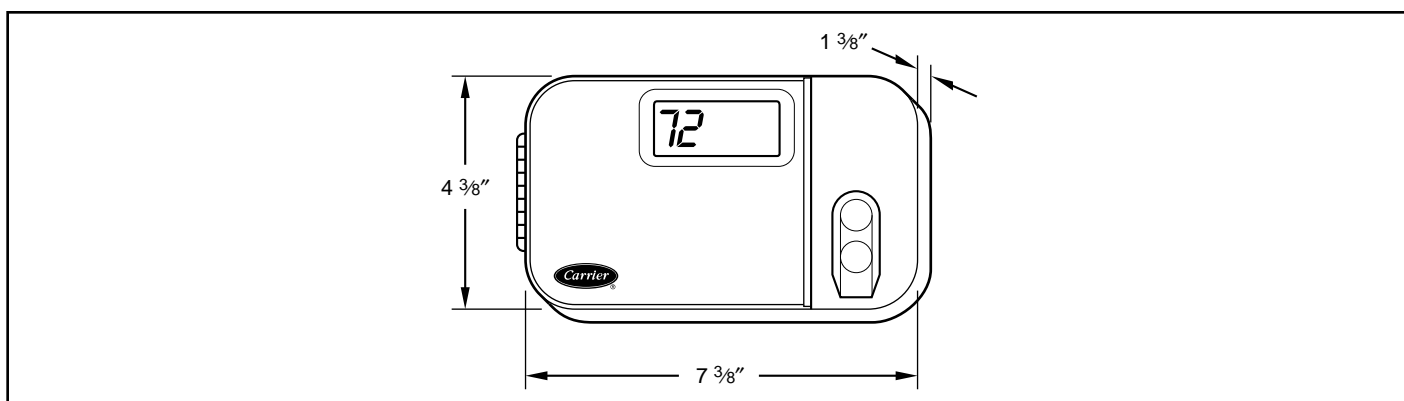

Non-Programmable Option—Offers the same popular humidity control benefits to consumers who do not need the added benefits of programming. Nine functional buttons, along with UP and DOWN buttons, make it easy to enter the temperature and humidity set points. The LCD is the largest display on the market for a non-programmable thermostat.

Limited Warranty—Standard 1-year warranty available on all parts.

Physical Characteristics

Dimensions: See drawing
 Appearance: Plastic, eggshell color, textured

Electrical Characteristics

Input Volts/Amps: 24vac, 5 VA

Environmental Requirements

Operating Temperature/Relative Humidity:
 32°F (0°C) to 104°F (40°C),
 95% rh non-condensing
 Storage Temperature/Relative Humidity:
 -40°F (-40°C) to 134°F (56°C),
 95% rh non-condensing

Wiring Requirements

Power: 24 vac nominal, 18- to 30-vac. 50/60 Hz
 Wiring: Standard thermostat wire 18 to 22 gage.

Program Specifications

Temperature set point range: 40°F (4°C) to 90°F (32°C)
 Separate heat and cool set points
 Auto changeover—can be disabled
 Clean filter reminder: installer adjustable
 Permanent memory
 Programming days: 7 day
 Programming periods: 4—Wake, Day, Eve, Sleep
 Hold function
 Copy previous day function
 Humidity display and control
 Equipment On indicator

SUBMITTAL DATA

Date _____
 Job Name _____
 Architect _____
 Engineer _____
 Contractor _____
 Unit Designation _____

UNIT DATA

Location _____
 Unit Model No. _____
 Unit Volts-Phase-Hertz _____
 Operating Voltage Range _____
 P.O.# _____

ACCESSORIES

