

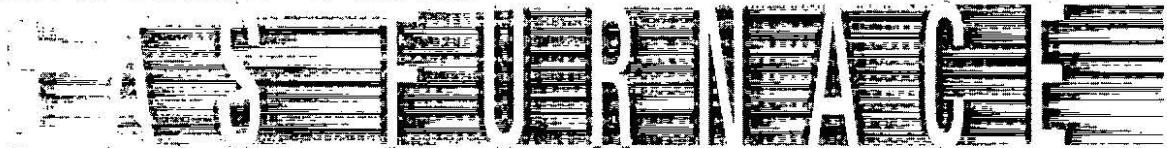

DELUXE  
CONDENSING FURNACE

58DXC &  
58SXC

HEATING & COOLING



**WARNING:** If the information in this manual is not followed exactly, a fire or explosion may result causing property damage, personal injury or loss of life.

- Do not store or use gasoline or other flammable vapors and liquids in the vicinity of this or any other appliance.
- **WHAT TO DO IF YOU SMELL GAS:**
  - Do not try to light any appliance.
  - Do not touch any electrical switch; do not use any phone in your building.
  - Immediately call your gas supplier from a neighbor's phone. Follow the gas supplier's instructions.
  - If you cannot reach your gas supplier, call the fire department.
- Installation and service must be performed by a qualified installer, service agency or the gas supplier.

**USER'S INFORMATION MANUAL  
FOR THE OPERATION AND  
MAINTENANCE OF YOUR NEW  
GAS-FIRED FURNACE**

**FILE COPY**



**WeatherMaker**

G A S F U R N A C E

*Hot Surface Ignition*

**High Efficiency**

**NOTE TO INSTALLER:  
THIS MANUAL MUST BE LEFT WITH  
THE EQUIPMENT USER.**

## Welcome to a new generation of comfort

Congratulations! In light of rising energy costs, the Weathermaker deluxe gas-fired, condensing furnace is one of the soundest investments today's homeowner can make.

Your new Weathermaker is truly a triumph of technology in home heating. A revolutionary design employs 2 heat exchangers to "squeeze" out the maximum amount of heat from the fuel consumed. In fact, your new furnace is so efficient, over 90%\* of the heat generated during combustion is captured and delivered inside your home. That's more than a 33%\* increase in heating efficiency over conventional furnaces.

The Weathermaker is not only 1 of the most energy-efficient furnaces you can buy today, it is also 1 of the safest and most dependable. We are proud of the technological advances incorporated into the design of the Weathermaker. With only minimal care, your new furnace will deliver many years of money-saving home comfort and enjoyment. Spend just a few minutes with this manual to learn the operation of your new furnace and the small amount of maintenance it takes to help keep it operating at peak efficiency year after year.

\*The output capacity and any representations of efficiency for this furnace are based on standard Department of Energy test procedures.



1

**MODEL 58SXC  
UPFLOW FURNACE**



2

**MODEL 58DXC  
DOWNFLOW FURNACE**

## Upflow furnace components

- 1 Gas valve. Safe, efficient. Features 2 separate gas shut-off valves.
- 2 Burner assembly. Operates with hot surface ignitor, inshot burners, and flame sensor for safe, dependable heating.
- 3 Primary serpentine heat exchanger (inside). Stretches fuel dollars with the S-shaped heat flow design. Solid construction of corrosion-resistant aluminized steel means reliability.
- 4 Secondary condensing heat exchanger (inside). Wrings out more heat through condensation. Constructed with polypropylene-laminated steel to ensure durability.
- 5 Inducer motor. Pulls hot flue gases through the heat exchangers, maintaining negative pressure for added safety.
- 6 Vent outlet. Uses PVC pipe to carry vent gases from the home.
- 7 Condensate drain trap. Collects moisture condensed from burned gases for disposal into home drain system.
- 8 Heavy-duty blower. Circulates air upwards, scrubbing the heat exchangers to speed condensation and transfer extra heat into the home.
- 9 Air filter and retainer spring.
- 10 Manual-reset flame rollout switch.

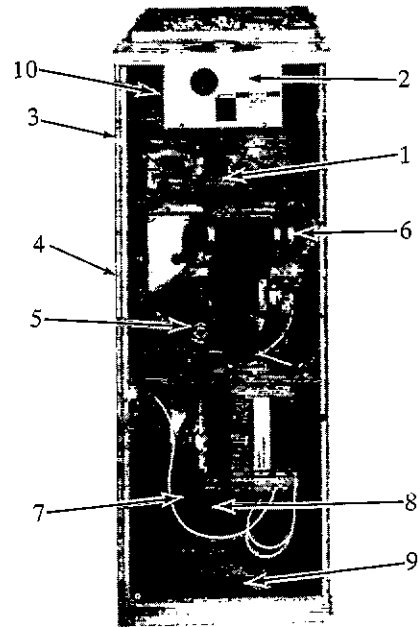

3

## MODEL 58SXC UPFLOW FURNACE

## Downflow furnace components

- 1 Gas valve. Safe, efficient. Features 2 separate gas shut-off valves.
- 2 Burner assembly. Operates with hot surface ignitor, inshot burners, and flame sensor for safe, dependable heating.
- 3 Primary serpentine heat exchanger (inside). Stretches fuel dollars with the S-shaped heat flow design. Solid construction of corrosion-resistant aluminized steel means reliability.
- 4 Secondary condensing heat exchanger (inside). Wrings out more heat through condensation. Constructed with polypropylene-laminated steel to ensure durability.
- 5 Inducer motor. Pulls hot flue gases through the heat exchangers, maintaining negative pressure for added safety.
- 6 Vent outlet. Uses PVC pipe to carry vent gases from the home.
- 7 Condensate drain trap. Collects moisture condensed from burned gases for disposal into home drain system.
- 8 Heavy-duty blower. Circulates air downwards, scrubbing the heat exchangers to speed condensation and transfer extra heat into the home.
- 9 Manual-reset auxiliary limit switch.
- 10 Manual-reset flame rollout switch.

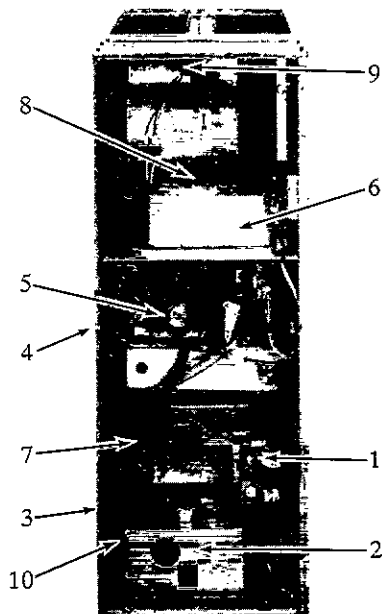

4

## MODEL 58DXC DOWNFLOW FURNACE

**NOTE:** See Fig. 28 for filter location.

## Important facts

Your gas furnace uses air from **outside the home** for combustion and venting. It is not to be installed using in-house air. Therefore, both pipes must terminate outside the structure. These pipes must not be obstructed in any way.

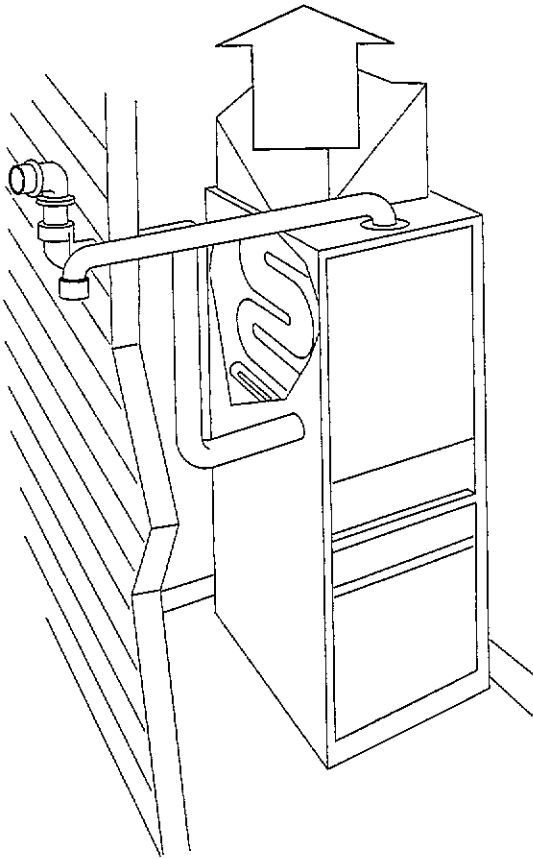

5

To minimize the possibility of serious personal injury, fire, damage to your furnace, or improper operation, **carefully follow these safety rules:**

- Keep the area around your furnace free of combustible materials, gasoline, and other flammable liquids and vapors.
- Do not cover the furnace, store trash or debris near it, or in any way block the flow of fresh air to the unit.
- A furnace installed in an attic or other insulated space must be kept free and clear of insulating material. Exam-

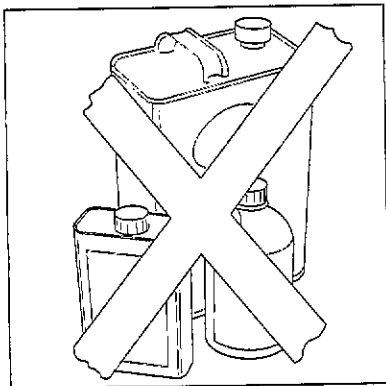

6

ine the furnace area when installing the furnace or adding more insulation. Some materials may be combustible.

**NOTE:** Do not use this furnace if any part has been under water. Immediately call a qualified service technician to inspect the furnace and to replace any part of the control system and any gas control which has been under water.

**NOTE:** The qualified installer or agency must use only factory-authorized replacement parts, kits, and accessories when modifying this product.

This furnace contains SAFETY DEVICES which must be **MANUALLY RESET**. If the furnace is left unattended for an extended period of time, have it checked periodically for proper operation. This precaution will prevent problems associated with **NO HEAT**, such as frozen water pipes, etc. See "Before You Request a Service Call" in this manual.

## Safety considerations

Installing and servicing heating equipment can be hazardous due to gas and electrical components. Only trained and qualified personnel should install, repair, or service heating equipment.

Untrained personnel can perform basic maintenance functions such as cleaning and replacing air filters. All other operations must be performed by trained service personnel. Observe safety precautions in this manual, on tags, and labels attached to the furnace and other safety precautions that may apply.

Recognize safety information: This is the safety-alert symbol  $\Delta$ . When you see this symbol on the furnace and in instructions or manuals, be alert to the potential for personal injury.

Understand the signal word—**DANGER**, **WARNING**, or **CAUTION**. These words are used with the safety-alert symbol. **DANGER** identifies the most serious hazards which **will** result in severe personal injury or death. **WARNING** signifies hazards that **could** result in personal injury or death. **CAUTION** is used to identify unsafe practices, which would result in minor personal injury or product and property damage.

## Starting your furnace

Instead of a continuously burning pilot flame which wastes valuable energy, your furnace uses an automatic hot surface ignition system to light the burners each time the thermostat turns your furnace on. **Follow these important safeguards:**

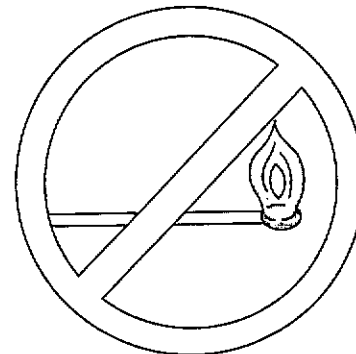

7

- Never attempt to light the burners manually with a match or other source of flame.
- Read and follow the operating instructions on the furnace, especially the item that reads as follows:

Wait 5 minutes to clear out any gas. Then smell for gas, including near the floor. If you smell gas, **STOP!** Follow "B" in the safety information above on this label. If you don't smell gas, go to the next step.

- If a suspected malfunction occurs with your gas control system, such as the burners not lighting when they should, refer to the shutdown procedures on the furnace or in the next section to turn off your system, then call your dealer as soon as possible.

### ▲ WARNING

**If overheating occurs, or the gas valve fails to shut off the gas supply, turn OFF the manual gas valve (see Fig. 9) to the furnace BEFORE turning OFF the electrical supply. Failure to follow this warning could result in a fire or explosion, and personal injury or death.**

- **CHECK AIR FILTER:** Before attempting to start your furnace, be sure the furnace filter is clean and in place. (See the maintenance section of this manual.) Then proceed as follows:

### Steps for starting your furnace

1. Set your room thermostat to the lowest temperature setting. (See Fig. 8.)
2. Close the external manual gas valve. (See Fig. 9.)

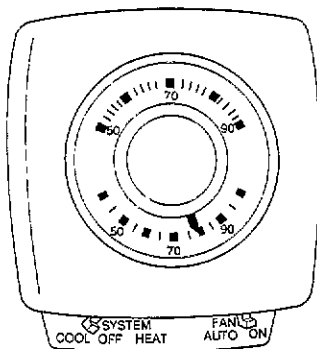

8

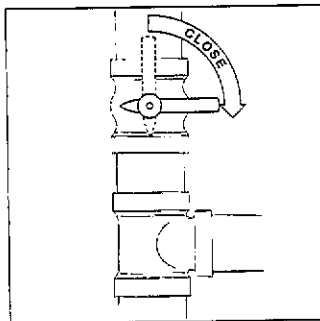

9

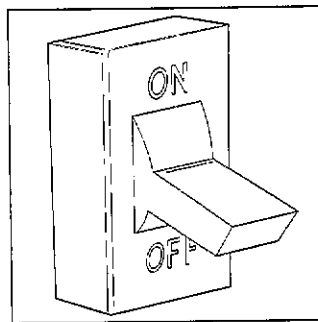

10

3. Turn OFF the electrical supply to the furnace. (See Fig. 10.)
4. Remove the furnace access door(s).
  - a. Upflow—remove control door. (See Fig. 11.)
  - b. Downflow—Remove blower door first, then remove the control door. (See Fig. 12.)

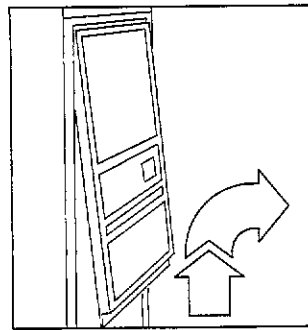

11

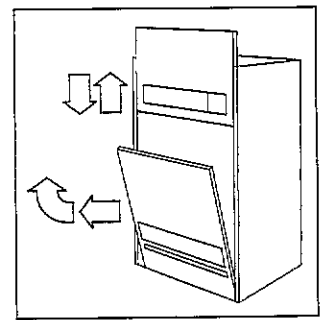

12

5. Turn the control knob on the gas valve to the OFF position and wait 5 minutes. (See Fig. 13.)
6. After waiting 5 minutes, turn the control knob on the gas valve to the ON position. (See Fig. 13.)
7. Replace the access door(s). See Fig. 14 for upflow and Fig. 15 for downflow models. Replace control door first on downflow furnaces. Then replace blower door.
8. Turn ON the electrical supply to the furnace. (See Fig. 16.)
9. Open the external manual gas valve. (See Fig. 17.)

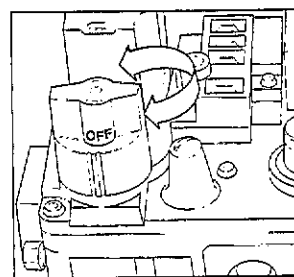

13

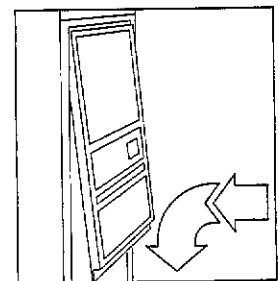

14

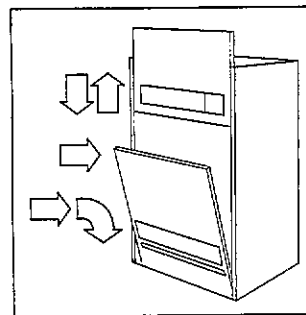

15

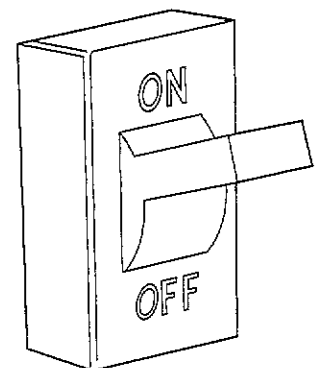

16

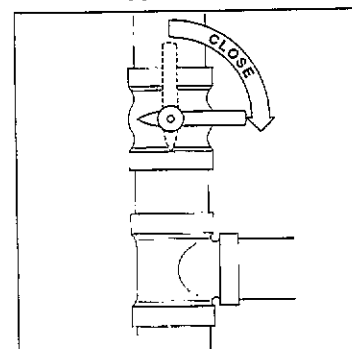

17

10. Set the room thermostat to a temperature slightly above room temperature. This will automatically signal the furnace to start. The inducer motor will start, and the hot surface ignitor will energize. When hot, the ignitor will have an orange glow.
11. After 30 to 58 sec, the gas valve permits gas to flow to the main burners where it is ignited. Hot flames begin to warm the furnace's heat exchanger. After a time delay of approximately 60 sec, the furnace blower is switched on.

**NOTE:** If the main burners fail to ignite, the furnace control system will go through 3 more ignition cycles. Then, if burners fail to ignite, the system will lockout. If lockout occurs, or the blower doesn't come on, shut down your furnace and call your dealer for service.

12. Set your thermostat to the temperature that satisfies your comfort requirements. **SUGGESTION:** Setting the thermostat back a few degrees—and compensating for the difference with warmer clothing—can make a big difference in your fuel consumption on extremely cold days. The few degrees at the top of your thermostat "comfort level" are the most costly degrees to obtain.

When the room temperature drops below the temperature selected on the thermostat, the furnace will be switched on automatically. When the room temperature reaches the degree selected on the thermostat, the furnace will be automatically switched off.

Some thermostats have a "fan" switch with 2 selections: AUTO or ON. When set on AUTO, the furnace blower cycles on and off, controlled by the thermostat. In the ON position, the furnace blower runs continuously except for a 60-sec delay at the "call for heat." This keeps the temperature level in your home more evenly balanced. It also continuously filters the indoor air.

## Shutting down your furnace

Should you need to shutdown your furnace, you will need to turn the furnace off. The following procedures must be followed:

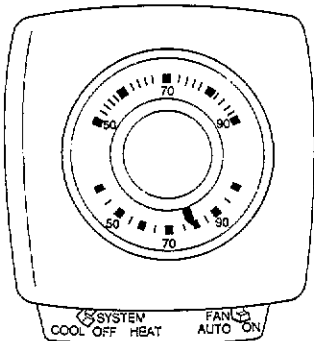

18

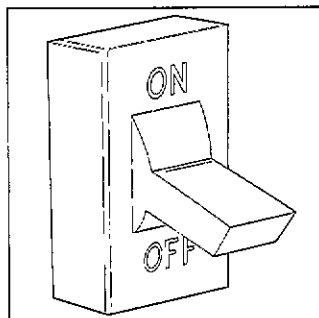

19

1. Set your room thermostat to the lowest temperature setting. (See Fig. 18.)
2. Close the external manual gas valve. (See Fig. 9.)
3. Turn OFF the electrical power to your furnace. (See Fig. 19.)
4. Remove the control access door on your furnace. (See Fig. 11 or 12.)
5. Turn the control knob on the gas valve to the OFF position. (See Fig. 20.)

6. Replace the control access door. (See Fig. 14 or 15.)
7. If the furnace is being shut down because of a malfunction, call your dealer as soon as possible.

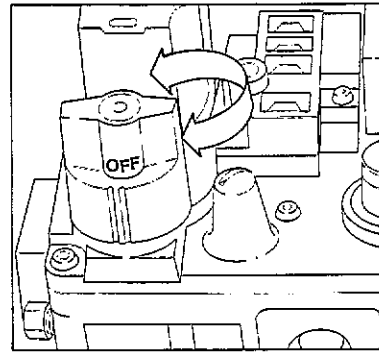

20

## ⚠ CAUTION

Furnace is not to be installed, operated, and then turned off and left turned off in an unoccupied structure during winter. (See winterizing procedures in maintenance section).

## Performing routine maintenance

With proper maintenance and care, your furnace will operate economically and dependably. Instructions for basic maintenance, which can easily be followed, are found on this and the following pages. However, before beginning maintenance, follow these safety precautions:

## ⚠ WARNING

Turn OFF electrical power supply to your furnace before removing the access doors to service or perform maintenance. Failure to follow this warning could result in personal injury or death.

## ⚠ CAUTION

Although special care has been taken to minimize sharp edges, be extremely careful when handling parts or reaching into the furnace.

## Filtering out trouble

A dirty filter will cause excessive stress on the furnace blower motor and can cause it to overheat and automatically shut down. The furnace filter should be checked every 3 or 4 weeks and cleaned if necessary.

## ⚠ CAUTION

Never operate your furnace without a filter in place. Doing so may damage the furnace blower motor. An accumulation of dust and lint on internal parts of your furnace can cause a loss of efficiency.

The air filter for upflow furnaces is normally located in the blower compartment. (See Fig. 3.) Filters for the downflow furnaces are normally located in the return-air plenum above the blower. (See Fig. 28.) If the filters have been installed in another location, contact your

dealer for instructions. To inspect, clean and/or replace the air filter(s), follow these steps:

**• Upflow Furnaces Only:**

1. Turn OFF the electrical supply to the furnace. (See Fig. 19.)
2. Remove control and blower access doors. (See Fig. 21 and 22.)

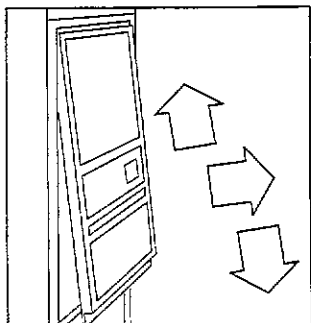

21

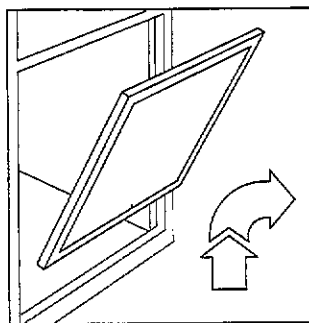

22

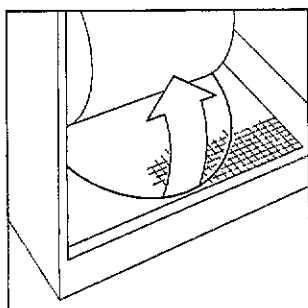

23

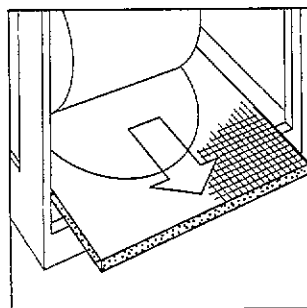

24

3. Push filter retainer toward the back of the furnace until it clears the flange on the furnace casing. (See Fig. 23.)
4. Gently remove the filter and carefully turn the dirty side up (if dirty) to avoid "spilling" dirt from the filter. (See Fig. 24.)
5. Inspect the filter. If torn, replace it.
6. Wash the filter (if dirty) in a sink, bathtub, or outside with a garden hose. Always use cold tap water. A mild liquid detergent may be used if necessary. Spray water through the filter in the opposite direction of airflow (through the cross-mesh binding side). Allow filter to dry.
7. Reinstall the clean filter with the cross-mesh binding side facing the furnace blower.
8. Push filter retainer toward back of the furnace until it will go behind the flange on the furnace casing.

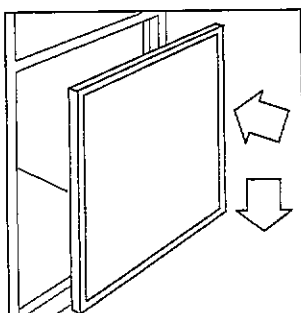

25

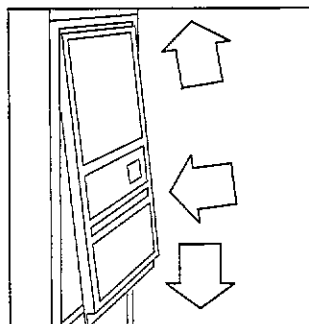

26

9. Replace blower and control access doors (see Fig. 25 and 26) and turn ON electrical power to your furnace.

If your furnace filter needs to be replaced, be sure to use the same size and type of filter that was originally supplied. Use the furnace filter table and compare your furnace size with the proper filter size.

**UPFLOW FURNACE FILTER TABLE**

UPFLOW FURNACE CASING WIDTH	FILTER SIZE (IN.)	FILTER TYPE
17-1/2	(1) 15-7/8x27-3/4x1	Cleanable
21	(1) 19-1/2x27-3/4x1	Cleanable
24-1/2	(1) 22-7/8x27-3/4x1	Cleanable

**• Downflow Furnaces Only:** 2 filters are located in the return-air plenum above the blower (above line-of-sight) attached to the top of the furnace. (See Fig. 28.)

1. Turn OFF electrical supply to the furnace. (See Fig. 19.)
2. Remove blower access door. (See Fig. 27.)

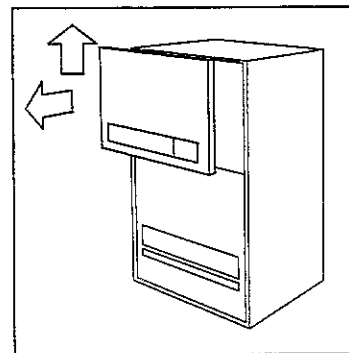

27

3. Remove the first filter (on side of furnace opposite the side where vent pipe exits) by tipping the filter toward the center — raise it from the V-shaped channel in which it rests. (See Fig. 28 and 29.)
4. Lower filter down along side of the blower and remove from the furnace.
5. To remove the second filter, lift from V-shaped channel and remove same way as first filter.

**DOWNFLOW FURNACE FILTER TABLE**

DOWNFLOW FURNACE CASING WIDTH	FILTER SIZE (IN.)	FILTER TYPE
All	(2) 16 x 20 x 1	Cleanable

6. Inspect the filters. If torn, replace them.
7. Wash the filters (if dirty) in a sink, bathtub, or outside with a garden hose. Always use cold tap water. A mild liquid detergent may be used if necessary. Spray water through the filter in the opposite direction of airflow through the cross-mesh binding side. Allow filter to dry.
8. Reinstall clean filters with the cross-mesh binding side facing the furnace blower.
9. Replace blower door (see Fig. 30) and turn ON electrical power to your furnace.

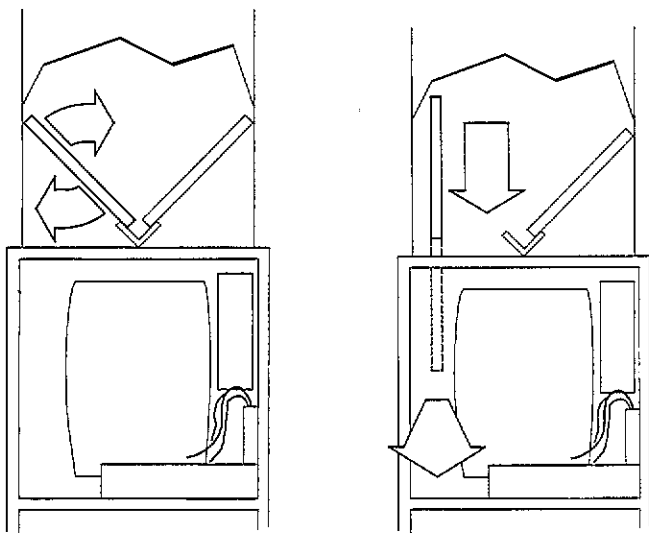

28

29

### Combustion area and vent system

Visually inspect the combustion area and vent system before each heating season. Make sure that all PVC pipes leading into the combustion area and vent are free from any cracks and sags. Also check the combustion air intake and vent pipes on the outside of your home for blockage.

When dirt, soot or rust is allowed to build up, your furnace can suffer a loss of efficiency and perform improperly. Accumulations on the main burners can result in their firing out of normal sequence. This delayed ignition will create an alarmingly loud sound.

#### ⚠ CAUTION

**If your furnace makes an especially loud noise when the main burners light, shut down your furnace and call your dealer.**

To inspect the combustion area and vent system, you will need a flashlight. Refer to Fig. 3 or 4, and proceed as follows:

1. Turn OFF the electrical supply to your furnace and remove the access doors. (See Fig. 10 and 11 or 12.)
2. Remove burner enclosure front. (See Fig. 31 or 32.)

Inspect the gas burners for dirt, rust, or scale. (See Fig. 33.) Then inspect the vent outlet area and vent pipe.

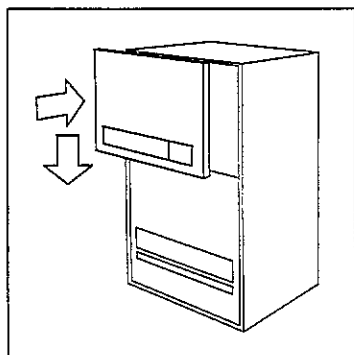

30

**⚠ CAUTION**  
**If dirt, rust, soot, or scale accumulations are found, call your dealer.**  
**Do not operate your furnace.**

3. Inspect the vent pipe for sag, holes, cracks, or disconnection.

#### ⚠ DANGER

**If holes are found in the vent pipe, or if it has become disconnected, toxic fumes can escape into your home. DO NOT OPERATE YOUR FURNACE.**  
**Call your dealer for service.**

4. Reinstall the burner enclosure front.
5. If your furnace is free of the above conditions, replace the access door and restore electrical power to your furnace. (See Fig. 14 or 15, and 16.)
6. Start your furnace and observe its operation. Watch the burner flames to see if they are bright blue. (See Fig. 33) If you observe a suspected malfunction, or the burner flames are not bright blue, call your dealer.
7. If your furnace is operating properly, reinstall the control access door.

### Heading south for the winter?

#### DON'T FORGET YOUR FURNACE!

Since the furnace uses a condensing heat exchanger, some water will accumulate in the unit as a result of the heat transfer process. Therefore, once it has been operated, it cannot be turned off and left off for an extended period of time when temperatures will reach 32°F or lower, unless winterized. Follow these procedures to winterize your furnace:

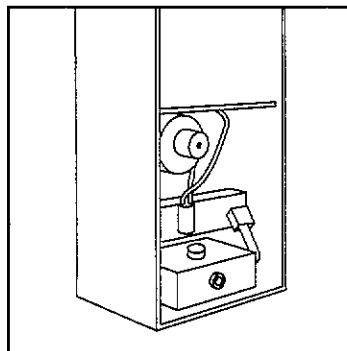

31

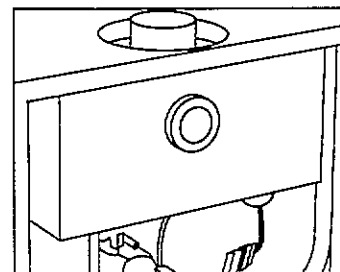

32

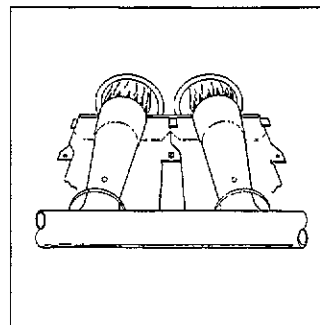

33

1. Mix a solution of equal amounts of ethylene glycol (Prestone II antifreeze coolant or equivalent) and water.
2. Turn OFF electrical supply to furnace. (See Fig. 10.)
3. Remove control access panel. (See Fig. 11 or 12.)
4. Disconnect drain tube from bottom of inducer vent outlet. (See Fig. 34 or 35.)

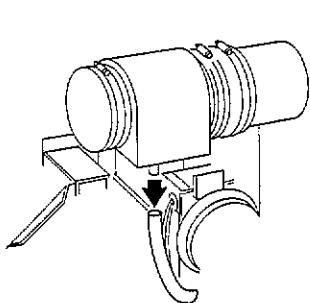

34

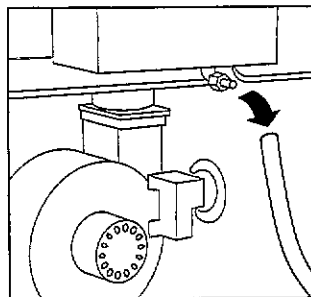

35

5. Insert funnel in drain tube and pour antifreeze/water solution into furnace until it is visible at point where condensate enters open drain. (See Fig. 36.)
6. Reconnect drain tube to vent outlet.
7. Replace control access panel. (See Fig. 14 or 15.)

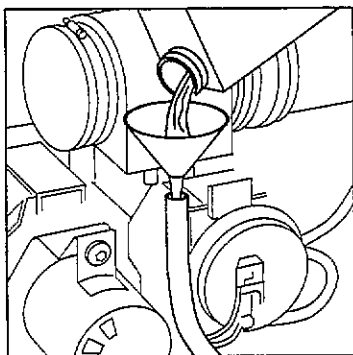

36

## A checkup checklist

Your furnace represents an important investment in your family's comfort and your home's value. To keep it in top shape and as a preventative to future problems, have a trained service specialist give your furnace a professional check-up annually. The following checklist can be used as a guideline to proper service:

- Inspect all flue gas passages, burners, heat exchangers, coupling box(es), and inducer assembly.
- Inspect all combustion and ventilation air passages and openings, including combustion air and vent pipe terminations outside the structure.
- Check gas pipes leading to and inside of your furnace for leaks.
- Inspect, clean, and lubricate the blower motor and wheel as required.

**NOTE:** If oil ports are provided, refer to the unit Service and Maintenance Instructions for blower motor oiling information. The motor must be oiled by a qualified service technician.

- Inspect and change or clean air filter(s) if necessary.

- Inspect all supply- and return-air ducts for obstructions, air leaks, and insulation. Remedy any problem when necessary.
- Inspect electrical wiring, connections, and components for loose connections.
- Perform an operational checkout to determine whether your furnace is working properly and if it requires adjustments.

- Inspect all condensate tubes and connections, condensate trap assembly, and drain for leaks. The condensate removal system should be cleaned annually by a qualified service agency; refer to the Service and Maintenance Instructions for further information.

- Examine the physical support of the furnace; the support should be sound with no cracks, sagging, gaps, etc. around the base.

- Check the furnace for any obvious signs of deterioration.

## Before you request a service call

If your furnace is not operating or not performing properly, you may save the expense of a service call by checking a few things yourself before calling for service.

### FOR INSUFFICIENT AIRFLOW:

- Check for dirty air filter(s).
- Check for blocked return-air or supply-air grilles throughout your home.

If problem still exists, call your dealer for service.

### WHEN FURNACE FAILS TO OPERATE:

Follow this checklist step by step, advancing to the next 1 only if furnace fails to start.

- Check thermostat for proper temperature.
- Is the thermostat switch on HEAT?
- Check fuses and circuit breakers.
- Is the blower door properly in place?
- Is the manual shut-off valve in gas supply pipe in open position? (Follow start-up procedures if you open gas valve.)

**NOTE:** Turn OFF the electrical power supply and remove access doors before continuing with checklist.

- Is the control knob on gas valve in ON position? (Follow start-up procedures if you must reset knob to ON.)
- Check the manual-reset flame rollout switch located on the left side of the burner assembly. (See Fig. 3 or 4.) If the furnace has experienced high temperature conditions, this switch will shut off the furnace. Reset it by pushing the button on the switch. If it trips again, shut down the furnace and call for service, see "Shutting Down Your Furnace" in this manual.
- **DOWNFLOW FURNACE ONLY:** Check the manual-reset auxiliary limit switch located on the blower housing. (See Fig. 4.) If the blower motor fails, this switch will shut off the furnace. Reset it by pushing the button on the switch. If it trips again, shut down the furnace and call for service, see "Shutting Down Your Furnace" in this manual.

If your furnace still fails to operate, call your service representative.

For your convenience, record the product and serial numbers on the form below. Should you ever require service,

you will have ready access to the information needed by your service representative.

### INSTALLATION DATA

Date Installed \_\_\_\_\_

Dealer Name \_\_\_\_\_

Address \_\_\_\_\_

City \_\_\_\_\_

State \_\_\_\_\_ Zip \_\_\_\_\_

Telephone \_\_\_\_\_

### FURNACE

Product No. \_\_\_\_\_

Model No. \_\_\_\_\_

Serial No. \_\_\_\_\_

### SPLIT-SYSTEM

Product No. \_\_\_\_\_

Model No. \_\_\_\_\_

Serial No. \_\_\_\_\_

### INDOOR COIL:

Product No. \_\_\_\_\_

Model No. \_\_\_\_\_

Serial No. \_\_\_\_\_

# Carrier Air Conditioning Company

Division of  
Carrier Corporation



## FOR SERVICE OR REPAIR, FOLLOW THESE STEPS IN ORDER:

- FIRST:** Contact the installer. You may find his name on the product or in your Owner's Packet. If his name is not known, call your builder if yours is a new residence.
- SECOND:** Contact the nearest CARRIER distributor. (See telephone yellow pages.)
- THIRD:** Contact:  
Carrier  
Consumer Relations  
P.O. Box 4952  
Syracuse, NY 13221-4952  
Phone: 1-800-CARRIER (TOLL FREE)

Model No. \_\_\_\_\_ Unit Serial No. \_\_\_\_\_  
Date of Installation \_\_\_\_\_ Installed by \_\_\_\_\_  
Name of Owner \_\_\_\_\_ Address of Installation \_\_\_\_\_

## Deluxe Gas-Fired Condensing Furnace Limited Warranty

**ONE-YEAR LIMITED WARRANTY**—CARRIER warrants to the original purchaser that this product will be free from defects in material and workmanship for a period of one year from the date of original installation (whether or not actual use begins on that date). At Carrier's sole option, a new or remanufactured part will be provided without charge to replace any defective part.

**THIS WARRANTY DOES NOT INCLUDE LABOR** or other costs incurred for diagnosing, repairing, removing, installing, shipping, servicing or handling of either defective parts or replacement parts. Such costs may be covered by a separate warranty or service agreement provided by the installer, which is separate and distinct from this factory warranty.

**EXTENDED 2-YEAR LIMITED WARRANTY ON MICROPROCESSOR CONTROL CENTER AND HOT SURFACE IGNITOR ONLY**—During the second through third years after the date of original installation, CARRIER further warrants the microprocessor control center and hot surface ignitor against defects in material or workmanship under normal use and maintenance. A new or remanufactured part, at CARRIER's sole option, will be provided under the same conditions as stated in the ONE-YEAR WARRANTY.

### EXTENDED WARRANTY ON HEAT EXCHANGER ONLY

**LIFETIME LIMITED WARRANTY**—Beginning on the date of original installation, CARRIER warrants to the original purchaser, during his or her lifetime, that the heat exchanger will be free from defects in material and workmanship, provided, however, this warranty shall apply only to the original installation of the furnace in a single family dwelling (i.e., where the furnace services only one dwelling unit) used without interruption by the purchaser as his or her principal residence.

**Twenty-Year Limited Warranty**—Where the owner of the dwelling is not the original purchaser and in multi-family dwellings (i.e., where the furnace services more than one dwelling unit) and in non-residential and other applications, CARRIER warrants the heat exchanger against defects in material and workmanship for a period of twenty years from the date of original installation.

In order to fill this warranty obligation in either above, CARRIER WILL, AT ITS OPTION, provide a new heat exchanger without charge, or allow a credit in the amount of the then current retail selling price of an equivalent heat exchanger toward the purchase price of a new CARRIER furnace, or provide a new furnace without charge if the retail price of a new furnace is less than the retail price of a new or equivalent heat exchanger.

### WARRANTY CONDITIONS

1. These warranties apply only to products in their original installation location and become void upon reinstallation.

2. Installation, use, care, and maintenance must be normal and in accordance with instructions contained in the owner's manual and CARRIER service information.
3. Defective parts must be returned to the distributor at purchaser's expense for credit.

**LIMITATIONS OF WARRANTIES**—ALL IMPLIED WARRANTIES (INCLUDING IMPLIED WARRANTIES OF MERCHANTABILITY AND FITNESS FOR A PARTICULAR PURPOSE) ARE HEREBY LIMITED IN DURATION TO THE PERIOD FOR WHICH THE APPLICABLE COMPONENT LIMITED WARRANTY IS GIVEN. SOME STATES DO NOT ALLOW LIMITATIONS ON HOW LONG AN IMPLIED WARRANTY LASTS, SO THE ABOVE MAY NOT APPLY TO YOU. THE EXPRESSED WARRANTIES MADE IN THIS WARRANTY ARE EXCLUSIVE AND MAY NOT BE ALTERED, ENLARGED, OR CHANGED BY ANY DISTRIBUTOR, DEALER, OR OTHER PERSON WHATSOEVER. ALL WORK UNDER THE TERMS OF THIS WARRANTY SHALL BE PERFORMED DURING NORMAL WORKING HOURS. ALL REPLACEMENT PARTS, WHETHER NEW OR REMANUFACTURED, ASSUME AS THEIR WARRANTY PERIOD ONLY THE REMAINING TIME PERIOD OF THE APPLICABLE COMPONENT WARRANTY.

### CARRIER WILL NOT BE RESPONSIBLE FOR:

1. Normal maintenance as outlined in the installation and servicing instructions or owners manual including filter cleaning and/or replacement and lubrication.
2. Damage or repairs required as a consequence of faulty installation, misapplication, abuse, improper servicing, unauthorized alteration or improper operation.
3. Failure to start due to voltage conditions, blown fuses, open circuit breakers or other damages due to the inadequacy or interruption of electrical service.
4. Damage as a result of floods, winds, fires, lightning, accidents, corrosive environments or other conditions beyond the control of CARRIER.
5. Parts not supplied or designated by CARRIER, or damages resulting from their use.
6. CARRIER products installed outside the continental U.S.A., Alaska, Hawaii and Canada.
7. Electricity or fuel costs or increases in electricity or fuel costs from any reason whatsoever including additional or unusual use of supplemental electric heat.
8. ANY SPECIAL INDIRECT OR CONSEQUENTIAL PROPERTY OR COMMERCIAL DAMAGE OF ANY NATURE WHATSOEVER. Some states do not allow the exclusion of incidental or consequential damages, so the above limitation may not apply to you.

This warranty gives you specific legal rights, and you may also have other rights which vary from state to state.

Form No. 530-062

Effective on products manufactured after May 4, 1992.

Supersedes any other warranty certificates supplied with the product.



TO OBTAIN INFORMATION ON PARTS: Consult your installing dealer or classified section of your local telephone directory under the "Heating Equipment" or "Air Conditioning Contractors & Systems" headings for dealer listing by brand name. Have available the Model No., Series Letter & Serial No. of your equipment to insure correct replacement part.

**Carrier Corporation • Syracuse, New York 13221**

Manufacturer reserves the right to discontinue, or change at any time, specifications or designs without notice and without incurring obligations.