

Installation Instructions

TSTATCCPB101
TSTATBBPB101
P474-1010

Digital Thermostat

NOTE: Read the entire instruction manual before starting the installation.

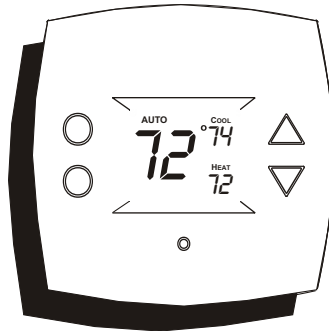

**HEAT
COOL
&
HEAT
PUMP**

MULTI-STAGE • SINGLE DAY PROGRAMMABLE

Table Of Contents

PREPARATION	2
REMOVE OLD THERMOSTAT	3
INSTALL BACKPLATE & WIRE	4
WIRING DIAGRAMS	5
CALIBRATION	8
TEST OPERATION	9
TROUBLESHOOTING	10

CAUTION Follow *Installation Instructions* carefully.



DISCONNECT POWER TO THE HEATER -
AIR CONDITIONER **BEFORE** REMOVING
THE OLD THERMOSTAT AND INSTALLING
THE NEW THERMOSTAT.



WARNING

Replacement Components Division © Carrier Corporation 4/01

This device complies with Part 15 of the FCC rules.
Operation is subject to the following 2 conditions:
(1) This device may not cause harmful interference,
and (2) This device must accept any interference
received, including interference that may cause
undesired operation.

STEP #1

PREPARATION



Proper installation of the thermostat will be accomplished by following these step by step instructions. If you are unsure about any of these steps, call a qualified technician for assistance.



Assemble tools as shown below.



*Flat Blade
Screwdriver*

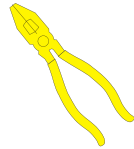

*Wire cutter
& Stripper*



*Drill with 3/16
inch Drill Bit
(when not using
j-box)*



Make sure your Heater/Air Conditioner is working properly before beginning installation of the thermostat.



Carefully unpack the thermostat. Save the screws, wall anchors, and instructions.

STEP #2

REMOVE OLD THERMOSTAT



Turn off the power to the Heating/Air Conditioning system at the main fuse panel. Most residential systems have a separate breaker for disconnecting power to the furnace.



Remove the cover of the old thermostat. If it does not come off easily check for screws.



Loosen the screws holding the thermostat base or subbase to the wall, and lift away.



Disconnect the wires from the old thermostat. Tape the ends of the wires as you disconnect them, and mark them with the letter of the terminal for easy reconnection to the new thermostat.



Keep the old thermostat for reference purposes, until your new thermostat is functioning properly.

STEP #3**INSTALL BACKPLATE & WIRE**

Remove the backplate connector from the rear of the thermostat. Install wires as directed below. When finished, snap thermostat on to backplate.



If the terminal designations on your old thermostat do not match those on the new thermostat, **refer to the chart below, or the wiring diagrams that follow.**

Wire from the old thermostat terminal marked	Function	Install on the new thermostat connector marked
G or F	Fan	G
Y1, Y or C	Cooling	Y1
W1, W or H	Heating	W1,O,B
Rh, R, M, Vr, A	Power	R
C	Common	C *
O/B	Rev. Valve	W1,O,B**
Y2	2nd Stage Cool	Y2
W2	2nd Stage Heat	W2
RS+5	Remote Sensor +5vdc	
RS	Remote Sensor Signal	
RS G	Remote Sensor Ground	
CK1	Dry Contact Switch 1	
CK2	Dry Contact Switch 2	

* C may not be used on all systems.

** O/B is used if your system is a Heat Pump.

Sample Wiring Diagrams

5 Wire, 1 Stage Cooling, 1 Stage Gas Heat

Residential Gas or Electric Heat *,
Electric Cool, split systems & package
units

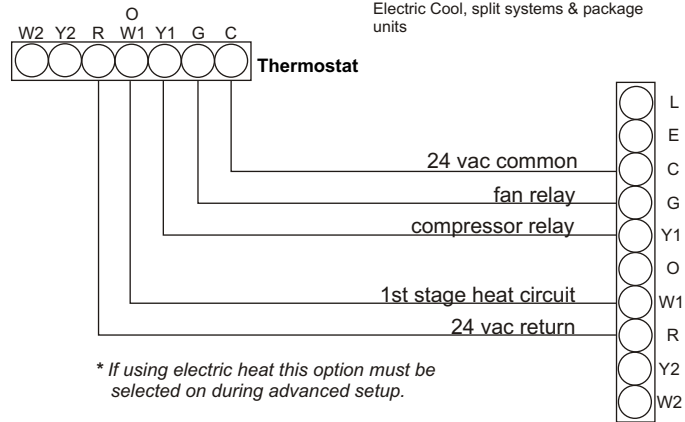

4 Wire, 1 Stage Cooling, 1 Stage Gas Heat

Residential Gas or Electric Heat *,
Electric Cool, split systems & package
units

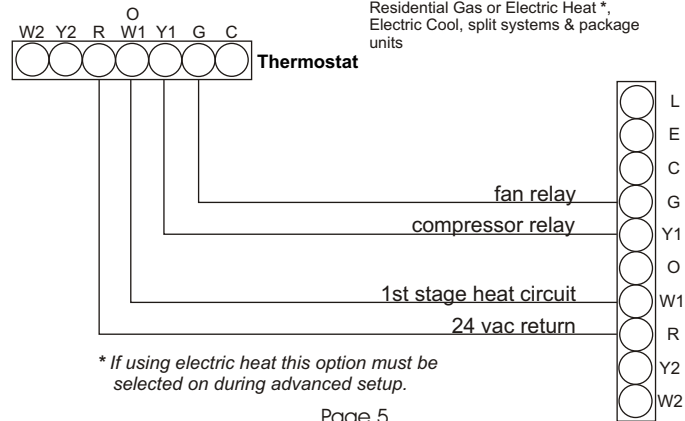

Sample Wiring Diagrams

6 Wire, 2 Stage Cooling, 1 Stage Heat

Residential 2 Stage Cooling, with Gas or Electric Heat*

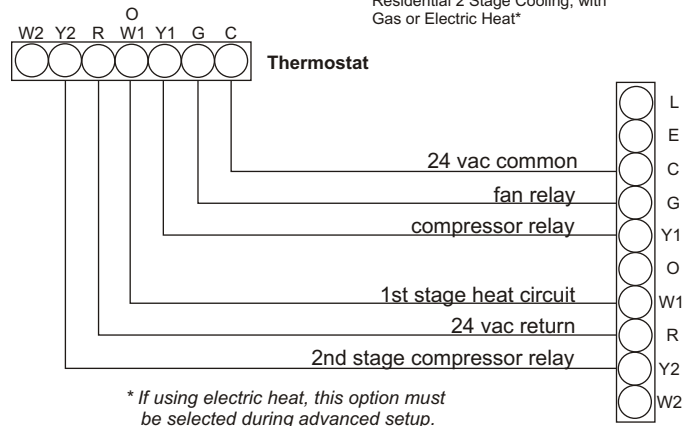

6 Wire, 1 Stage Cooling, 2 Stage Heat

Residential & commercial 1 Stage Cooling, with 2 Stage Gas or Electric Heat*

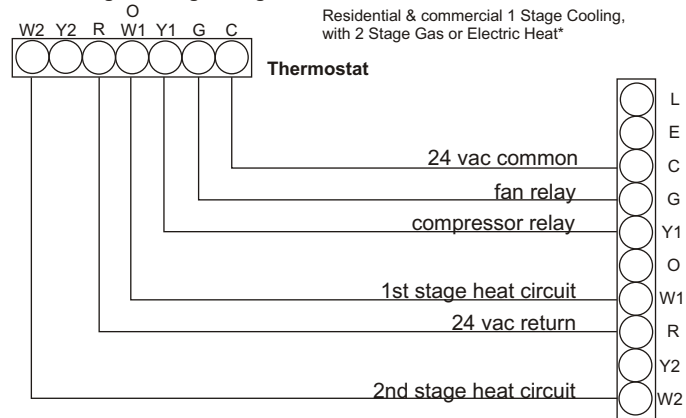

Sample Wiring Diagrams

7 Wire, 2 Stage Cooling, 2 Stage Heat

Commercial Gas or Electric Heat ***,
Electric Cool, split systems & package units
including Commercial Heat Pumps **

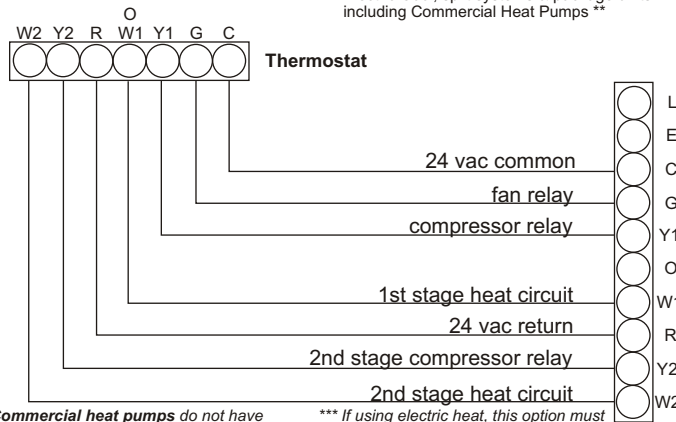

** Commercial heat pumps do not have the heat pump turned on in advanced setup.

*** If using electric heat, this option must be selected on during advanced setup.

5 Wire, 1 Stage Cooling, 1 Stage Heat - Heat Pump*

No auxiliary heat, residential Heat Pumps ,
split systems & package units

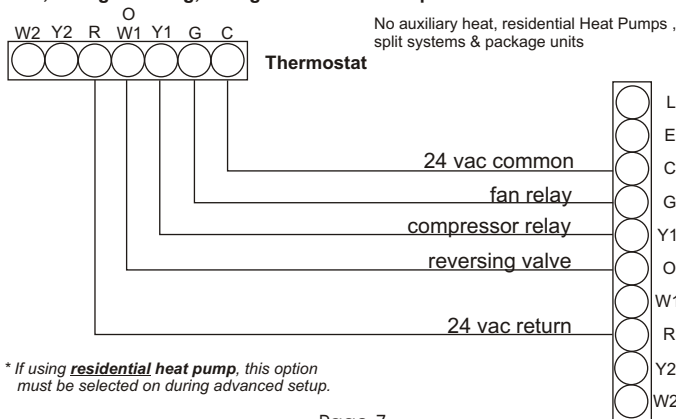

* If using residential heat pump, this option must be selected on during advanced setup.

Sample Wiring Diagram

6 Wire, 1 Stage Cooling, 2 Stage Heat, Heat Pump *

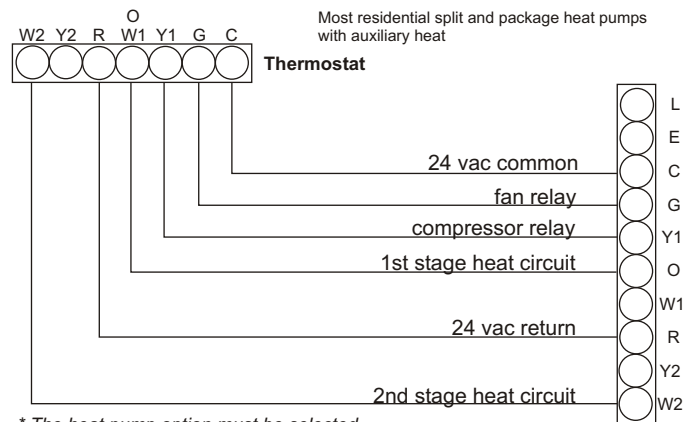

* The heat pump option must be selected on during advanced setup.

Calibration

Every thermostat is calibrated before it leaves the factory. Under normal circumstances there will never be a need to recalibrate the thermostat again.

To accommodate *special needs*, the thermostat may be recalibrated following these steps:

1. While holding the mode button in, press the down button for 2 seconds. After all the icons in the display appear, release the buttons.
2. Press the mode button.
3. Press the up or down buttons until the flashing number equals the current room temperature.
4. Press the mode button to return to normal operation.

STEP #4**TEST OPERATION**

Turn the power on to the Heating/Air Conditioning system.



Press the *MODE* button repeatedly until the **HEAT** icon appears on the display. Press the *up/down* buttons until the set temperature is 10 degrees above room temperature. The furnace should turn on.



Press the *MODE* button repeatedly until the **COOL** icon appears on the display. Press the *up/down* buttons until the set temperature is 10 degrees below room temperature. The air conditioner should turn on. **NOTE:** *Most equipment has a time delay of 5 minutes between cool cycles. This feature is defeatable on the thermostat. Consult the Owner's Manual under Setup, cycles per hour.*



Press the *MODE* button to **OFF**. Press the *FAN* button to **Fan On**. The fan should turn on and run continuously.

TROUBLESHOOTING



SYMPTOM: When using 4 wires (R, G, W, Y), the air conditioning or heat equipment tries repeatedly to turn on, but cannot. At times the display dims or disappears.

CAUSE: There is not enough power available to "power share".

REMEDY: Connect a 270 ohm, 10 watt power resistor **at the furnace** as shown below.

For Problem A/C

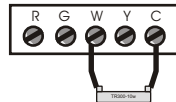

For Problem Heat

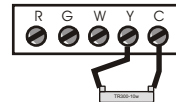

SYMPTOM: The air conditioning does not attempt to turn on.

CAUSE: The compressor timer lockout may prevent the air conditioner from turning on, for a period of time.

REMEDY: Consult the Owner's Manual in the Setup section to defeat the cycles per hour and compressor timeguard.



SYMPTOM: The display is blank.

CAUSE: Lack of proper power.

REMEDY: Make sure power is turned on to the furnace and that you have 24vac between **R & W**. If **C** is used, 24vac between **R & C**.

TROUBLESHOOTING



SYMPTOM: The air conditioning does not attempt to turn on.

CAUSE: The cooling setpoint is set too high.

REMEDY: Consult the Owner's Manual in the Setup section to lower the cooling setpoint limit.



SYMPTOM: The heating does not attempt to turn on.

CAUSE: The heating setpoint is set too low.

REMEDY: Consult the Owner's Manual in the Setup section to raise the heating setpoint limit.

TROUBLESHOOTING



SYMPTOM: When controlling a residential heat pump, and asking for cooling, the heat comes on.

CAUSE: Heat pump is not selected "on" in the Advanced Setup.

REMEDY: Select heat pump **on** during Advanced Setup programming. Consult the Owner's Manual.



SYMPTOM: When calling for cooling, both the heat and cool come on.

CAUSE: The Advanced Setup is configured to control a heat pump, and the hvac the thermostat is controlling is a "conventional" (non heat pump) system.

REMEDY: Consult the Owner's Manual in the Advanced Setup section to turn off the heat pump.



P/N 88-331