

MODEL AIRA ELECTRONIC AIR CLEANER

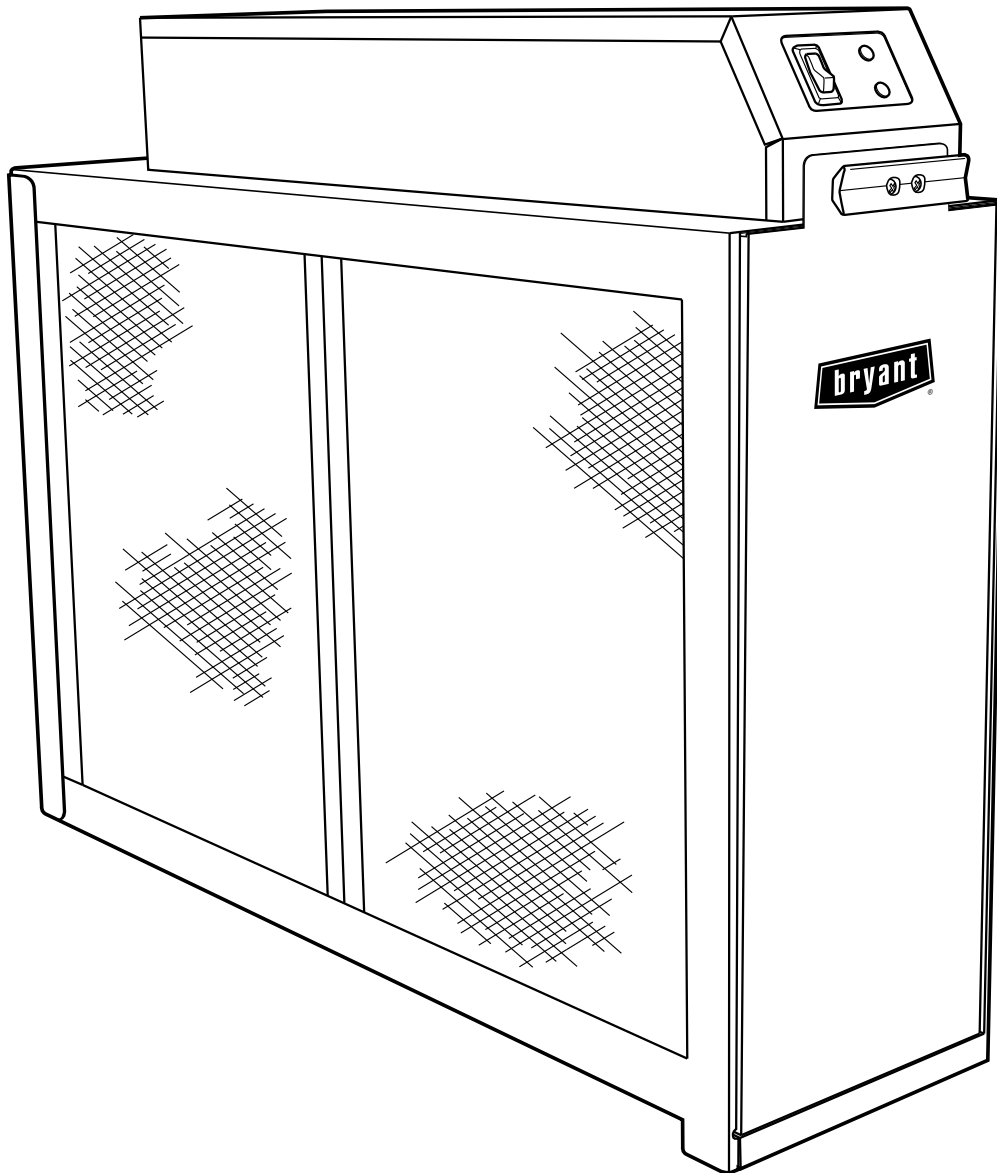

***NOTE TO
INSTALLER:
This manual
must be
left with the
equipment user.***

BREATH OF SPRING-FRESH AIR . . . YEAR-ROUND

Congratulations on your excellent choice and sound investment in this addition to your home comfort system.

Your electronic air cleaner represents both the latest in engineering development and the culmination of many years of experience from one of the most reputable manufacturers of comfort systems.

Your new unit is among the most energy-efficient and reliable air filtration products available today. To assure its dependability, spend just a few minutes with this booklet now. Learn about the operation of your electronic air cleaner and the small amount of maintenance it takes to keep it operating at peak efficiency.

With minimal care, your electronic air cleaner will provide you and your family with clean, healthy, and comfortable air—from season to season, and year to year.

YOUR ELECTRONIC AIR CLEANING UNIT

YOUR INDOOR AIR POLLUTION SOLUTION

The highest value of clean air is in its contribution to the good health and comfort of you and your family. Additional benefits include potential savings in home heating, cooling, and maintenance costs.

Your new air cleaner will electronically filter out microscopic particles as small as 0.01 micron. At that size, it would take 100,000 particles to cover the head of a pin. Such particles are 500 times smaller than the smallest grains of dust trapped by conventional furnace filters.

Airborne pollutants commonly found in the household are lint, dust, ash, pet hair and dander, pollen, fungus, spores, bacteria, viruses, cooking grease, and possibly tobacco smoke odors.

By ridding your home of most of these pollutants, the whole family can breathe fresher, safer air. Moreover, family members suffering from hay fever, asthma, or allergies may find relief, since electronic filtering removes many of the airborne particles responsible for aggravating these ailments. Electronic filtering removes airborne particles before they have a chance to settle, so

walls, windows, draperies, and furnishings stay clean and bright longer.

If your home is equipped with central air conditioning or a heat pump, electronic air cleaning can optimize your system's performance by keeping the indoor coil clean. At today's energy rates, the potential savings can be significant.

HOW YOUR AIR CLEANER WORKS

Contaminated air enters the prefilter (the mesh filter) where the larger airborne particles are removed. These include hair, fibers from carpets and drapes, pet hair, and some lint particles. (See Fig. 1a.)

The air then passes through the ionizer/collector cells. The ionizer wires produce positive ions that give airborne particles a positive electrical charge. (See Fig. 1b.)

Opposites attract: Airflow continues, passing between the collector plates. The positively charged particles are attracted and trapped by the grounded collector plates. (See Fig. 1c.) These particles continue to cling to the plates until you or your service technician remove the plates for cleaning.

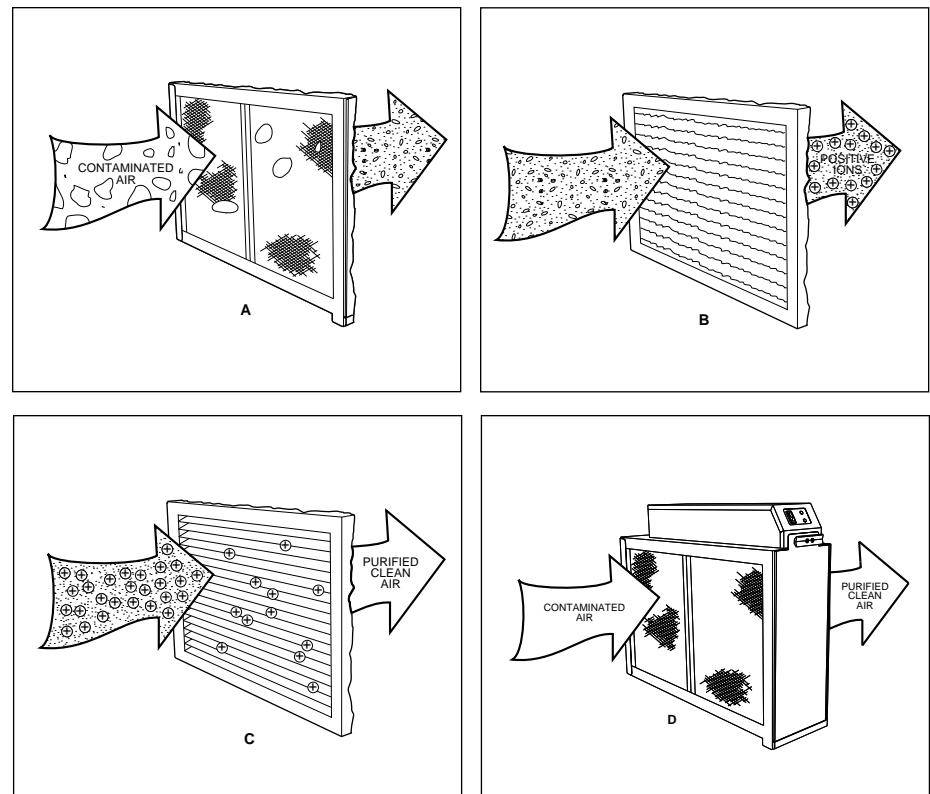

Fig. 1—Air Cleaner Process

Meanwhile, the purified air leaves the air cleaner and circulates into your living space. (See Fig. 1d.)

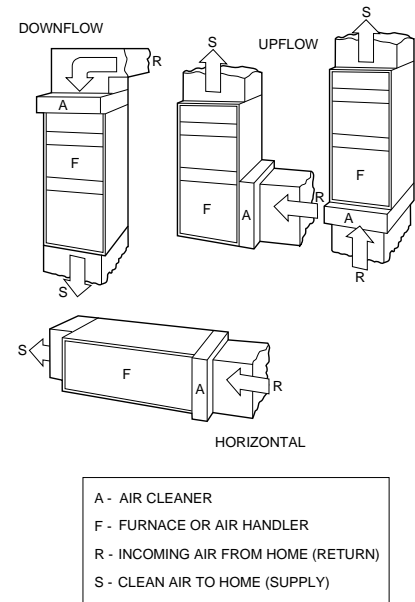

Fig. 2—Typical EAC Installations

OPERATING YOUR ELECTRONIC AIR CLEANER

Your new electronic air cleaner is designed to operate as part of your heating/cooling system. After the air cleaner is turned on, it will operate whenever the furnace or air handler blower is running.

Your electronic air cleaner will perform at maximum efficiency if these recommendations are followed:

- Consider running the heating/cooling system blower continuously—day and night, winter and summer. Continuous blower operation provides for constant air filtration. It may also contribute to greater personal comfort since continuous blower operation minimizes temperature differences throughout the home.
- Supply-air and return-air grilles should not be blocked. Drapes, furniture, and toys are some of the items commonly found obstructing grilles. Restricted airflow reduces the efficiency of the air cleaner, as well as that of the whole comfort system.
- The electronic air cleaner must be properly cleaned and maintained.

START-UP PROCEDURES

1. Ensure the air cleaner's door handle is engaged, latched, and power switch turned ON, powering unit.
2. Set the temperature control selector on your indoor thermostat. Choose a setting above current room temperature if heating is required. Set the temperature control selector below room temperature if cooling is needed.
3. Set the FAN mode on the thermostat. When set to AUTO, the air cleaner and system blower will run only while the thermostat operates the heating or cooling equipment. When the FAN mode is set at the ON position, the air cleaner and blower

will run continuously—regardless of whether the cooling or heating equipment is operating.

4. Select operating mode of HEAT, COOL, or AUTO.

NOTE: The operation light (green) indicates that power is available to the electronic air cleaner. It does not indicate that power is available to the cells.

NOTE: An occasional arcing (snapping) noise is normal during the operation of your air cleaner. Continuous arcing, however, indicates that cleaning is required. Refer to directions on cleaning your electronic air cleaner.

PERFORMING ROUTINE MAINTENANCE

With the proper maintenance and care, your electronic air cleaner will operate economically and dependably. Maintenance can be accomplished easily by referring to the following directions. However, before performing any maintenance, consider these important safety precautions:

- **DISCONNECT ALL ELECTRICAL POWER TO THE AIR CLEANER AND FURNACE OR AIR HANDLER BEFORE PERFORMING ANY SERVICE OR MAINTENANCE.**

NOTE: THERE MAY BE MORE THAN 1 ELECTRICAL DISCONNECT SWITCH.

The prefilter and ionizer/collector cells should be checked for dirt regularly. Accumulated dirt needs to be removed from these components to maintain efficient air filtration.

Regular inspection allows you to determine the cleaning schedule best suited to your home's operating conditions. The first electronic air cleaning of your home may collect more particles over a shorter period than will be normal for future operation.

As your air cleaner collects particles, its cleaning efficiency will decline which

makes it all the more important to clean your air cleaner regularly.

At minimum, the prefilter and collection cells will need to be cleaned 4 or 6 times per year. Ask your dealer about the installation of a Bryant thermostat which has a "Clean Filter" capability to remind homeowners to check/clean their air cleaner. After about 400 hr of operation, the thermostat will display a "Clean Filter" icon when it is time to clean the filter. (See Fig. 3.)

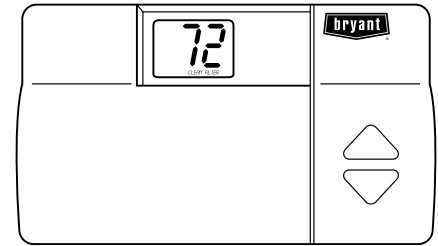

Fig. 3—Thermostat

CLEANING PROCEDURES

Regular washing is necessary to insure proper performance. A thorough washing once every 2–3 months will be adequate for most installations. More frequent washing (once a month) may be necessary on some installations (new homes for example) where there is new carpeting, plaster dust, or there is above normal cigarette smoke. (See Fig. 4.)

1. To remove the cells and prefilter
 - a. Push the air cleaner switch to OFF. Wait 15 seconds. Open the access door.
 - b. Carefully remove the cells and prefilter, and set aside.
 - c. Avoid damage to the cell plates and ionizing wires.

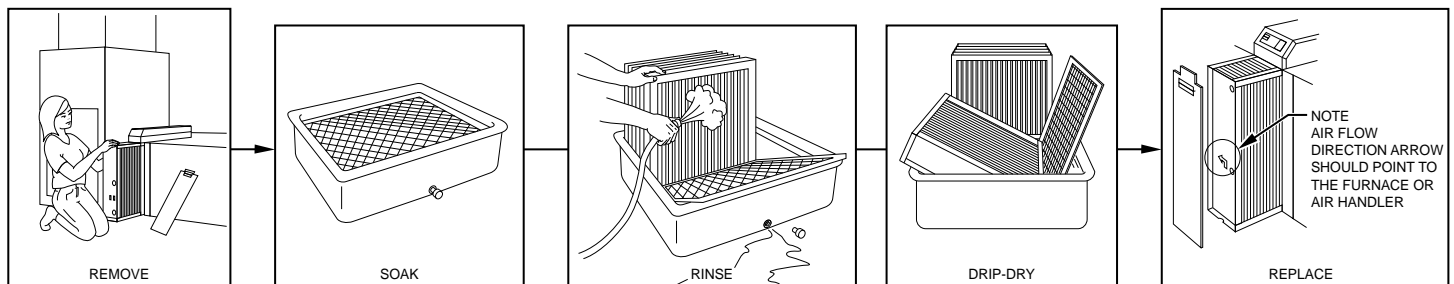

Fig. 4—Cleaning Procedures

2. To wash the cells in a tub

- a. Place enough hot water in a utility tub to cover the cell. Electronic air cleaner concentrate solution (Part No. P902-2001) is recommended. (The solution is available from your dealer through our Replacement Components Division.) As an alternative, 2 to 4 oz of automatic dishwasher detergent (not laundry detergent) can be used.
- b. Allow the cell to soak for 30 minutes. Agitate it up and down in the solution until it appears clean, then remove.
- c. Repeat with the second cell.
- d. Agitate the prefilter up and down in the solution until they appear clean.
- e. With a hose, rinse the cells and prefilter. The hose should be held about 10 in. from the cell plates and at a slight angle for better cleaning results. The cell frame should be thoroughly rinsed along the edges to dislodge any trapped lint or dirt. Carefully wipe a damp cloth or sandpaper (not emery cloth) along the ionizing wires.
- f. Stand the cells and prefilter up to drain. Let dry for 2 hr.

We do not recommend washing the electronic air cleaner cells in the dishwasher. Not only can the collector plates and ionizing wires be easily damaged, but dirt from the cells and prefilter can permanently stain plastic dishwasher linings.

3. To replace the cells and prefilter

- a. Replace the prefilter and cells in the cabinet. Check that the arrow on the cells points in the same direction as the air flows through the duct. The arrow should be pointing to the air handler or furnace. (If you have to force it past the positioning screw on the bottom, it is probably in a wrong position.)

- b. Reposition the access door (engage the tips on the lower edge of the door into the slots in the cabinet). Carefully close the door.
- c. Turn the air cleaner switch to ON.

OPERATION CHECKLIST

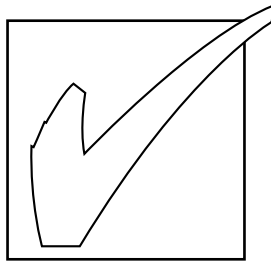

- Check the setting on your indoor thermostat. The FAN should be set at ON position for contin-

uous blower and electronic air cleaner operations, or AUTO if you wish the blower and air cleaner to function only when heating or cooling is required.

- Check the power switch on your electronic air cleaner. Be sure it is ON and the power indicator lamps (green and red) are glowing.

- Check the main power disconnect switch. Verify that the circuit breakers are ON or that fuses have not blown. If you must reset breakers or replace fuses, do so only once. Contact your servicing dealer for assistance if breakers trip or fuses blow a second time.

- Check electronic air cleaner components. Check for proper orientation of the prefilter and ionizer/collector cells. The prefilter must be on the farthest side from the furnace. Arrows stamped on the sides of the cells must point in the direction of the furnace. The prefilter and cells must be clean and dry.

- Check for sufficient airflow. Check for blocked return-air or supply-air grilles. Be sure grilles are open and unobstructed.

If your comfort system still fails to operate, contact your servicing dealer for troubleshooting and repairs. Specify your apparent problem, and state the model and serial numbers of your equipment.

With this information, your dealer may be able to offer helpful suggestions over the phone, or save valuable time through knowledgeable preparation for the service call.

REGULAR DEALER MAINTENANCE

In addition to the routine maintenance that you perform, your electronic air cleaner should be inspected regularly by a properly trained service technician. The inspection (preferably each year, but at least every other year) should include the following:

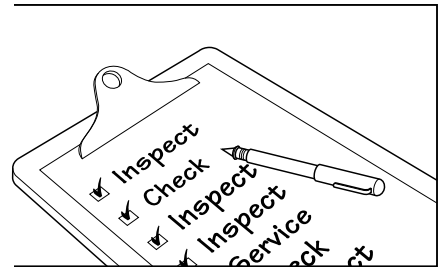

- Routine inspection of ionizer wires. Service should include realignment or replacement as required.
- A check of all electrical wiring and connections.
- Operational check of the complete comfort system to determine actual working condition. Necessary repair and/or adjustment should be performed at this time.

Your servicing dealer may offer an economical service contract that covers seasonal inspections. Ask for further details.

Record the model and serial numbers of your new electronic air cleaner in the spaces provided on page 8. This information, along with the other ready-reference facts requested below, may be required if you should ever need information or service.

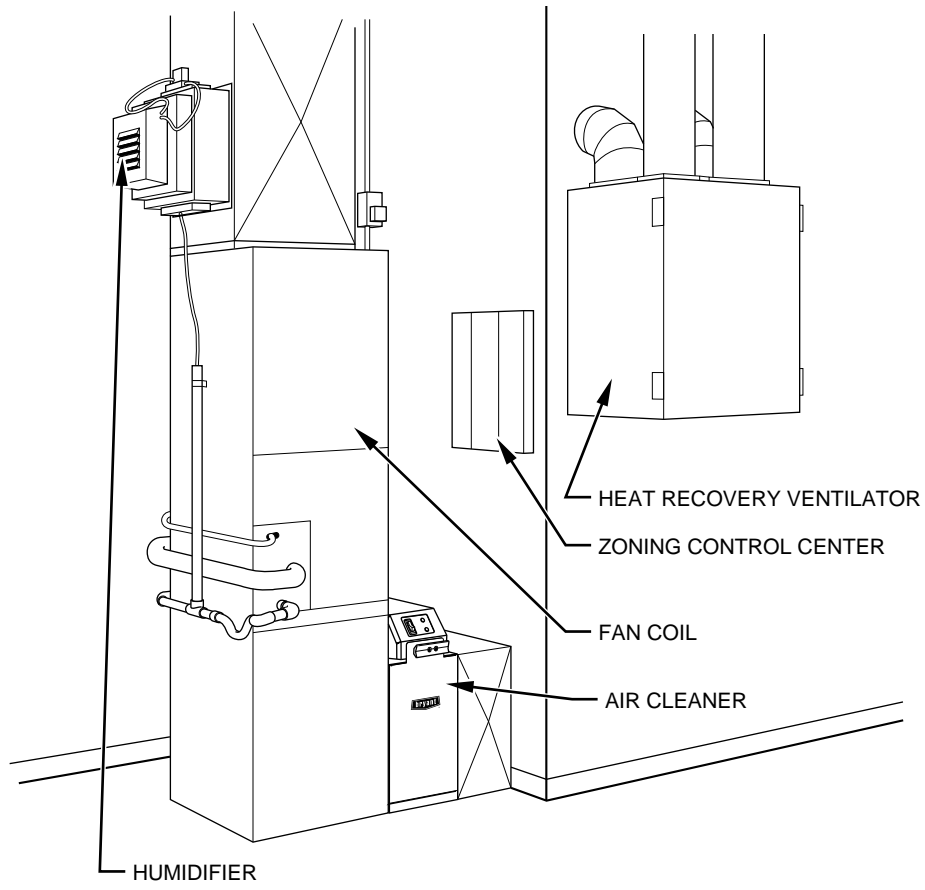

Model No. _____

Serial No. _____

Date Installed _____

Dealer Name _____

Address _____

City _____

State _____ Zip _____

Telephone _____

