



user's information manual

SINGLE PACKAGE ROOFTOP GAS HEATING/ELECTRIC COOLING UNITS

580F
Sizes 036-150
3 to 12¹/₂ Tons

Cancels: New

OM11-18
10/15/00

NOTE TO INSTALLER

This manual should be left with the equipment owner.

FOR YOUR SAFETY

Do not store or use gasoline or other flammable vapors and liquid in the vicinity of this or any other appliance.

⚠ WARNING: Improper installation, adjustment, alteration, service or maintenance can cause injury or property damage. Refer to this manual. For assistance or additional information consult a qualified installer, service agency, or the gas supplier.

FOR YOUR SAFETY WHAT TO DO IF YOU SMELL GAS

- Do not try to light any appliance.
- Do not touch any electrical switch; do not use any phone in your building.
- Immediately call your gas supplier from a neighbor's phone. Follow the gas supplier's instructions.
- If you cannot reach your gas supplier, call the fire department.

⚠ WARNING: Before performing recommended maintenance, be sure main power switch to unit is turned off and lockout tag is installed. Electrical shock could cause personal injury.

Your rooftop combination heating/cooling unit is equipped with an automatic direct spark ignition and induced draft combustion blower.

⚠ WARNING: Do not attempt to ignite gas by hand; personal injury may result.

TO LIGHT UNIT

⚠ DANGER:

1. Do not turn off the electrical power to unit without first turning off the gas supply.
2. Before attempting to start the gas heating section, familiarize yourself with all the procedures that must be followed.
3. Never attempt to manually light the main burners on unit with a match, lighter, or any other flame. If the electric sparking device fails to light the main burners, refer to the following shutdown procedures, then call your dealer as soon as possible.

If you do not follow these instructions exactly, a fire or explosion may result. Property damage, injury, or loss of life could occur.

See Fig. 1A and 1B for location of gas valve. Refer to Fig. 2 while proceeding with the following steps.

I. Step 1

Set room thermostat to the lowest temperature setting and set SYSTEM switch to HEAT or AUTO. position.

II. Step 2

Close the manual gas valve.

III. Step 3

Turn off the electrical supply to the unit and install lockout tag.

IV. Step 4

Remove the burner access panel.

V. Step 5

Move the control on the gas valve to the OFF position and wait 5 minutes.

VI. Step 6

Move control on gas valve to ON position.

VII. Step 7

Replace the burner access panel.

VIII. Step 8

Turn on the electrical supply to unit.

IX. Step 9

Open the manual gas valve.

X. Step 10

Set room thermostat selector slightly above room temperature to start unit. The induced-draft combustion air fan will start. Main gas valve will open and main burners should ignite within 5 seconds. If the burners do not light, there is a 22-second delay before another 5-second try. If the burner

still does not light, the time delay is repeated. If the burner does not light within 15 minutes, there is a lockout. If burners still do not light, call for service.

XI. Step 11

Set the temperature selector on room thermostat to desired setting.

⚠ WARNING: If the main burners fails to light, or the blower fails to come on, shut down gas heating section and call your dealer for service. Failure to follow these requirements could result in serious personal injury.

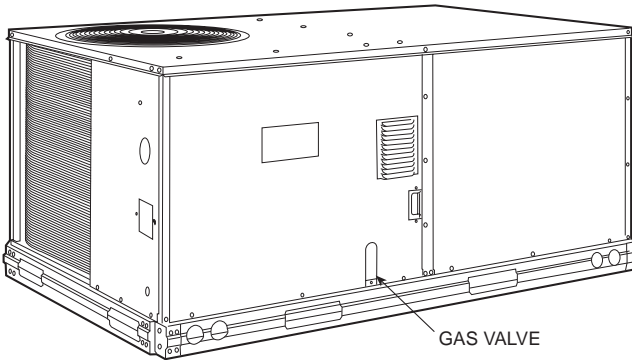

Fig. 1A — Gas Valve Location (Sizes 036-072)

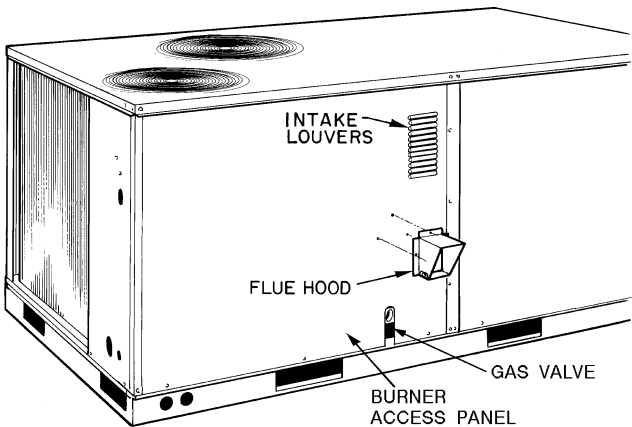

Fig. 1B — Gas Valve Location (Sizes 090-150)

TO SHUT UNIT OFF

⚠ WARNING: Do not turn off the electrical power to unit without first turning off the gas supply. Failure to follow this procedure can result in serious fire or personal injury.

Refer to Fig. 3 while proceeding with the following steps.

I. Step 1

Set room thermostat to lowest temperature setting and set SYSTEM switch to OFF position.

II. Step 2

Close the external manual gas valve.

III. Step 3

Turn off the electrical power supply to unit and install lock-out tag.

IV. Step 4

Remove the burner access panel.

V. Step 5

Move the control on the gas valve to the OFF position.

VI. Step 6

Replace the burner access panel.

VII. Step 7

If unit is being shut down because of a malfunction, call your dealer as soon as possible.

If unit is being shut down because the heating season has ended, restore electrical power to the unit to ensure operation of the cooling system during the cooling season.

Should overheating occur, or the gas supply fail to shut off, shut off the manual gas valve to the unit before shutting off the electrical supply.

Do not use this unit if any part has been under water. Immediately call a qualified service technician to inspect the unit and to replace any part of the control system and any gas control which has been under water.

MAINTAINING YOUR UNIT

All maintenance should be handled by skilled, experienced and qualified personnel. Your dealer can help you establish a standard procedure.

For your safety, keep the area around the unit clear and free of combustible materials, gasoline, and other flammable liquids and vapors.

To ensure proper functioning of the unit, flow of combustion and ventilating air must not be prevented from reaching the unit. Clearance of at least 3 ft on size 036-072 units and 4 ft on size 090-150 units on the flue and condenser sides and 6 in. on all other sides is required. A clearance of 5 ft is required above the condenser discharge.

ROUTINE MAINTENANCE AND CARE FOR THE EQUIPMENT OWNER

Consider the following information before maintaining or servicing equipment:

⚠ WARNING:

1. TURN OFF GAS SUPPLY AND THEN ELECTRICAL POWER TO YOUR UNIT BEFORE SERVICING OR PERFORMING MAINTENANCE.
2. Do not turn off electrical power to this unit without first turning off the gas supply.
3. When removing access panels or performing maintenance functions inside your unit, be aware of sharp sheet metal parts and screws. Although special care has been taken to reduce sharp edges inside the unit, be extremely careful when handling parts or reaching into the unit.

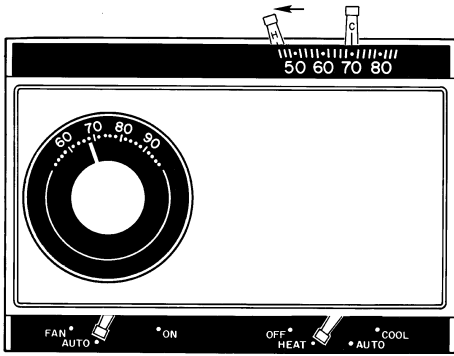

STEP 1

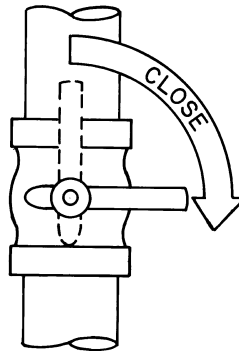

STEP 2

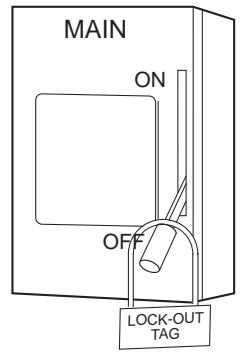

STEP 3

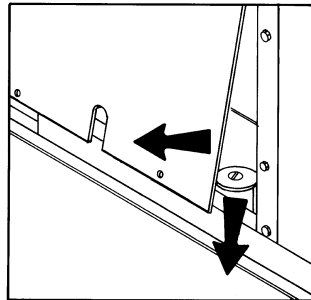
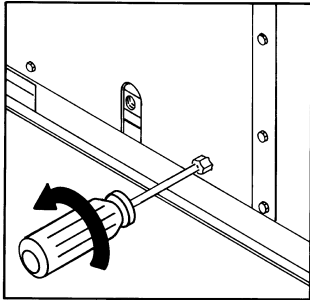

STEP 4

ONE-STAGE VALVE

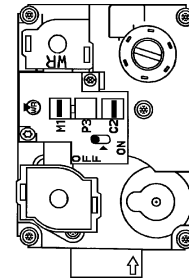

TWO-STAGE VALVE

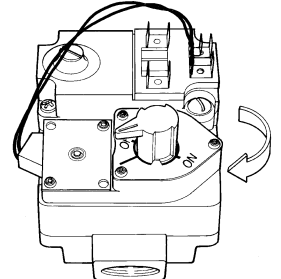

- 580F036074-072074
- 580F036060N-060060N
- 580F036090N-060090N
- 580F048120N-060120N
- 580F048115-072115
- 580F(J)048150-060150
- 580F(J)036115
- 580F036114
- 580F048149-060149
- 580F090125,102125

- 580F(E,P,T)036115
- 580F(E,P,T)048150-072150
- 580F090180-120180
- 580F090224-150224
- 580F120250,150250

ONE-STAGE VALVE

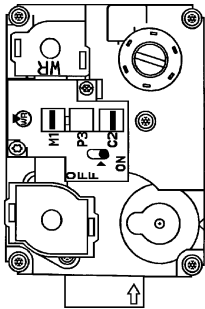

TWO-STAGE VALVE

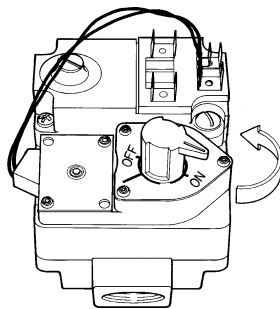

- 580F036074-072074
- 580F036060N-060060N
- 580F036090N-060090N
- 580F048120N-060120N
- 580F048115-072115
- 580F(J)048150-060150
- 580F(J)036115
- 580F036114
- 580F048149-060149
- 580F090125,102125

- 580F(E,P,T)036115
- 580F(E,P,T)048150-072150
- 580F090180-120180
- 580F090224-150224
- 580F120250,150250

STEP 5

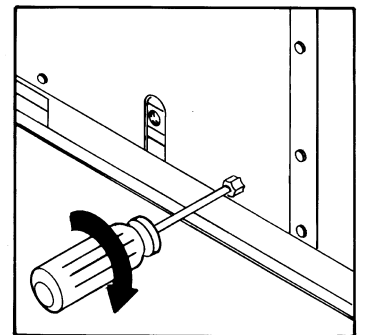
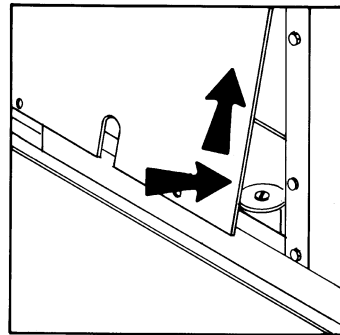

STEP 7

STEP 6

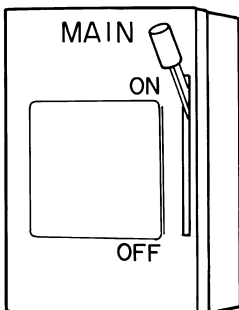

STEP 8

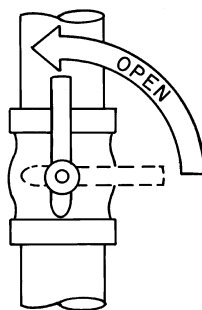

STEP 9

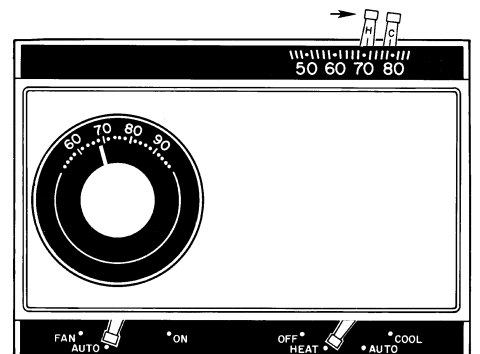

STEP 10

Fig. 2 — To Light Unit

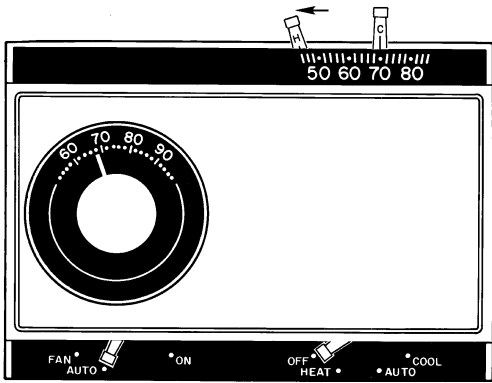

STEP 1

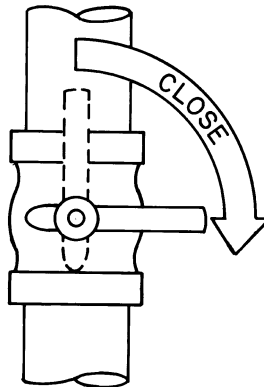

STEP 2

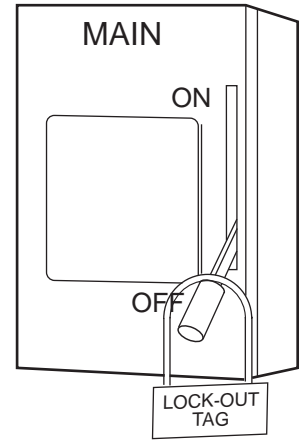

STEP 3

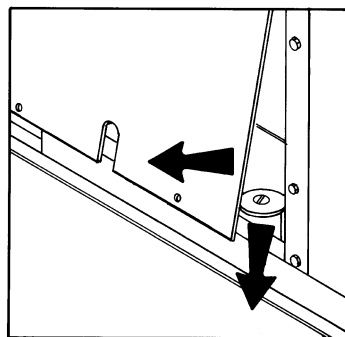
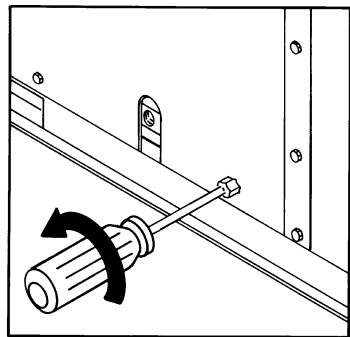

STEP 4

ONE-STAGE VALVE

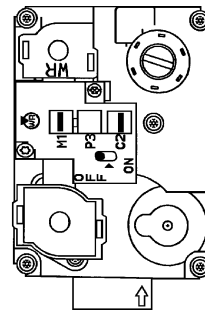

- 580F036074-072074
- 580F036060N-060060N
- 580F036090N-060090N
- 580F048120N-060120N
- 580F048115-072115
- 580F(J)048150-060150
- 580F(J)036115
- 580F036114
- 580F048149-060149
- 580F090125,102125

TWO-STAGE VALVE

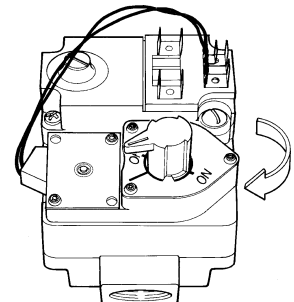

- 580F(E,P,T)036115
- 580F(E,P,T)048150-072150
- 580F090180-120180
- 580F090224-150224
- 580F120250,150250

STEP 5

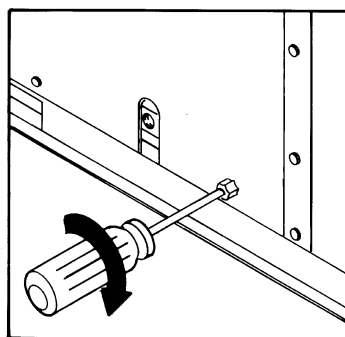
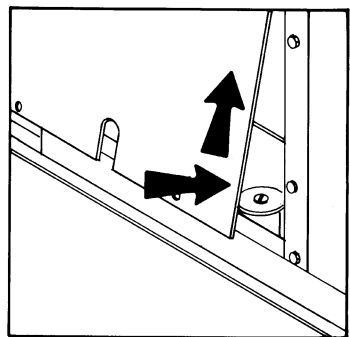

STEP 6

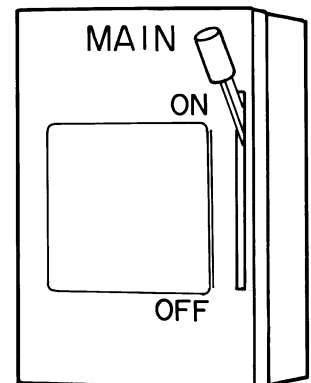

STEP 7

Fig. 3 — To Shut Unit Off

I. Air Filters

Air filter(s) should be checked at least every 3 or 4 weeks and changed or cleaned when necessary. Table 1 indicates the correct filter size for your unit. See Fig. 4 for filter access panel location.

To replace or inspect filters:

1. Set room thermostat to the lowest temperature setting and set SYSTEM switch to HEAT or AUTO position.
2. Close the manual gas valve.
3. Turn off the electrical supply to the unit and install lockout tag.
4. Lift up and remove filter access panel.
5. While holding filter, tilt upper filter rack retainer.
6. Remove filters by pulling up and out toward you from the track.
7. Inspect or replace filters.
8. Return filters to filter track. Note direction of airflow arrows on filter frame.
9. Replace filter access panel.
10. Reverse Steps 1 through 3.

If you have difficulty in locating your air filter, or if you have questions concerning proper filter maintenance, contact your dealer for instructions. When replacing your unit filters, always use the same size and type of filter that was originally supplied by the installer.

Units with outdoor air capability have a cleanable filter for the outdoor air. This filter should be checked annually and cleaned as necessary with steam or hot water and a mild detergent. Do not use throwaway filters in place of cleanable filters.

⚠ WARNING: Never operate your unit without filters in place. Failure to heed this warning may result in damage to the blower motor and/or compressor. An accumulation of dust and lint on internal parts of your unit can cause loss of efficiency and, in some cases, fire.

Table 1 — Indoor-Air Filter Data

UNIT SIZE 580F	INDOOR-AIR FILTERS (Throwaway Fiberglass)	
	Quantity	Size (in.)
036-072	2	16 x 25 x 2
090,102	4	16 x 20 x 2
120,150	4	20 x 20 x 2

NOTE: Replacement filters should be UL (Underwriters' Laboratories) certified or equivalent.

II. Heat Exchanger

To ensure dependable and efficient heating operation, the heat exchanger should be inspected by a qualified maintenance person before each heating season, and cleaned when necessary. This checkout should not be attempted by anyone not having the required expertise and equipment to do the job properly. Checking and/or cleaning the heat exchanger involves removing the gas controls assembly and the flue collector box cover and, when completed, reinstalling the gas controls assembly for proper operation. Also, the flue collector box cover must be replaced correctly so that a proper seal is maintained. Contact your dealer for the required periodic maintenance.

III. Fans, Belts and Fan Motor

Periodically check the condition of the fan wheels and housings, belt tension and fan motor shaft bearings. No lubrication of condenser or evaporator fan bearings or motors is required or recommended. Adjust or replace components as necessary.

IV. Evaporator and Condenser Coils

Cleaning of the coils should be done by qualified service personnel. Contact your dealer for the required annual maintenance.

V. Condensate Drain

The drain pan and condensate drain line should be checked and cleaned at the same time the cooling coils are checked by your dealer.

VI. Compressor

All compressors are factory supplied with a normal charge of the correct type refrigeration-grade oil in them and should not require additional oil.

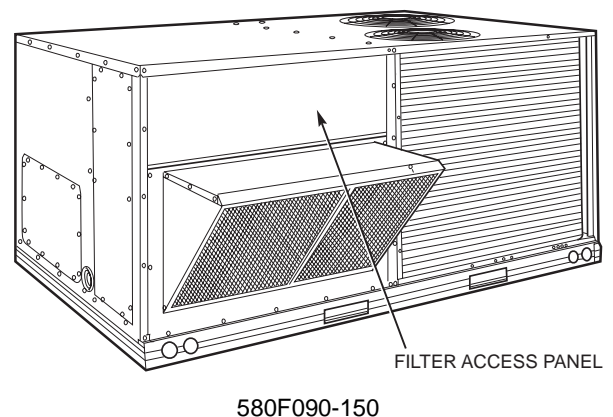
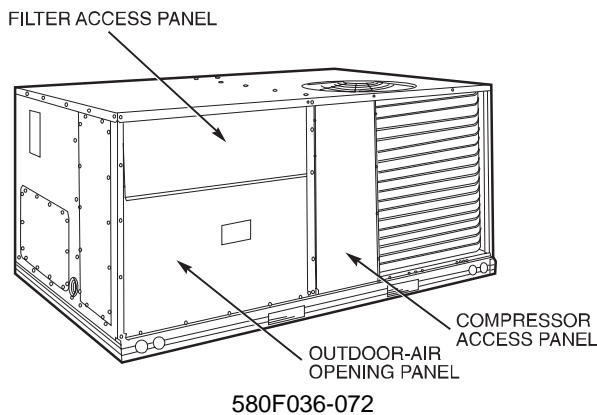

Fig. 4 — Typical Filter Access Panel Location

VII. Condenser Fan

⚠ WARNING: Do not poke sticks, screwdrivers, or any other object into revolving fan blades. Severe bodily injury may result.

The fan must be kept free of all obstructions to ensure proper cooling. Contact your dealer for any required service.

VIII. Electrical Controls and Wiring

Electrical controls are difficult to check without proper instrumentation; therefore, if there are any discrepancies in the operating cycle, contact your dealer and request service.

IX. Refrigerant Circuit

The refrigerant circuit is difficult to check for leaks without the proper equipment; therefore, if inadequate cooling is suspected, contact your local dealer for service.

X. Combustion Area and Vent System

The combustion area and vent system should be visually inspected before each heating season. The normal accumulation of dirt, soot, rust, and scale can result in loss of efficiency and improper performance if allowed to build up.

⚠ CAUTION: If your unit makes an unusual or especially loud noises during heating, shut down the heating section and call your dealer.

See Fig. 1A, 1B and 5 and proceed as follows to inspect the combustion area and power-venting system of your unit.

1. Turn off gas supply to your unit.
2. Turn off electrical power to your unit and install lock-out tag.
3. Remove burner access panel.
4. Using a flashlight, carefully inspect the burner areas for dirt, soot, rust or scale.

⚠ CAUTION: If dirt, soot, rust, or scale accumulations are found, call your dealer and do not operate your heating section.

5. When you have completed your inspection, follow the start-up procedures in this manual to restore your unit to operation.

6. Observe unit heating operation.

⚠ WARNING: Components in heat section may be hot after unit has been started up. When observing flame, be careful not to get too close to or touch heating components. Serious personal injury may result.

Watch the burner flame to see if it is bright blue. If you observe a suspected malfunction or that the burner flame is not bright blue, call your dealer.

7. Replace burner access panel.

XI. Unit Panels

After performing any maintenance or service on the unit, be sure all panels are securely fastened in place to prevent rain from entering unit cabinet and to prevent disruption of the correct unit airflow pattern.

REGULAR DEALER MAINTENANCE

In addition to the type of routine maintenance you might be willing to perform, your unit should be inspected regularly by a properly trained service technician. An inspection (preferably each year, but at least every other year) should include the following:

1. Inspection of all flue product passages — including the burner, heat exchanger, and flue collector box.
2. Inspection of all combustion- and ventilation-air passages and openings.
3. Close inspection of all gas pipes leading to and inside your unit.
4. Inspection, and if required, cleaning of the condenser and evaporator coils.
5. Inspection, and if required, cleaning of the condensate drain pan and trap.
6. Inspection of all supply- and return-air ducts for leaks, obstructions, and insulation integrity. Any problems found should be resolved at the time of inspection.
7. Inspection of the unit base for cracks, gaps, etc., which may cause a hazardous condition.
8. Inspection of the unit casing for signs of deterioration.
9. Inspection of all electrical wiring and components to ensure proper connection.
10. Inspection for leaks in the refrigerant circuit. Pressure-check to determine appropriate refrigerant charge.
11. Inspection and cleaning of fan wheels and housings, belt tension, and fan motor, shaft bearings, and pulley alignment.
12. Operational check of the unit to determine working conditions. Repair or adjustment should be made at the time of inspection.

Your servicing dealer may offer an economical service contract that covers seasonal inspections. Ask for further details.

Complete Service Instructions can be found in the unit Installation, Start-Up and Service Instructions.

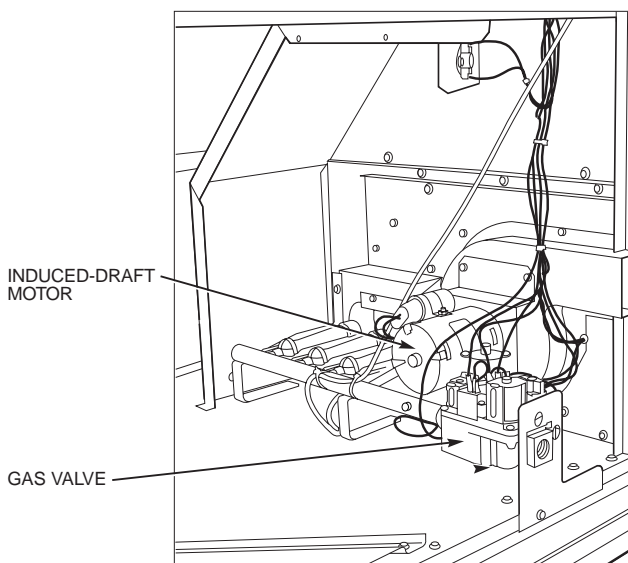

**Fig. 5 — Typical Heat Section Detail
(Size 036-072 Shown)**

BEFORE YOU CALL FOR SERVICE, CHECK FOR PROBLEMS THAT CAN BE EASILY SOLVED

If insufficient heating or cooling is suspected:

() Check for sufficient airflow. Check the air filter for dirt. Check for blocked return- or supply-air grilles. Be sure they are open and unobstructed. If these checks do not reveal the cause, call your servicing dealer.

If your unit is not operating at all, check the following list for easy solutions:

() Check to be sure that your thermostat temperature selector is set above the indoor temperature during the heating season, or below the indoor temperature during the cooling season. Be sure the SYSTEM switch is in the proper HEAT, COOL or AUTO. position and not in the OFF position.

() Is the electrical supply switch ON? Are any fuses blown, or has the circuit breaker tripped?

() During the heating season, check the external manual shutoff valve. Is this lever parallel with the pipe, indicating that the valve is open? Or is the lever at a right angle, indicating that the valve is closed? If closed, has the gas been shut off for safety reasons? Otherwise, you may open the valve and follow the start-up procedures listed in this manual.

NOTE: Before proceeding with the next check, turn OFF the electrical power supply to the unit. Remove the control access door.

() During the heating season, check the control dial on the gas valve. Is it in the ON position? If it is not, be sure it has not been turned off for safety reasons. If no safety hazards are present, follow the start-up procedures in this manual.

() If your unit still fails to operate, call your servicing dealer for troubleshooting and repairs. Specify the model and serial numbers of your unit. (Record them in this manual in the space provided.) If the dealer knows exactly which unit you have, he may be able to offer suggestions over the phone, or save valuable time through knowledgeable preparation for the service call.

IN CASE OF TROUBLE

If, after performing the above, unit performance is unsatisfactory, shut off the unit and call your dealer.

Dealer's Name _____

Telephone No. _____

Unit Model _____



Bryant Heating & Cooling Systems

FOR SERVICE OR REPAIR, FOLLOW THESE STEPS IN ORDER:

- FIRST:** Contact the installer. You may find his name on the product or in your Homeowner's Packet. If his name is not known, call your builder if yours is a new residence.
- SECOND:** Contact the nearest distributor. (See telephone yellow pages.)
- THIRD:** Contact:
 BRYANT HEATING & COOLING SYSTEMS
 Consumer Relations Department
 P.O. Box 4952
 Syracuse, New York 13221-4952
 Phone: 1-800-428-4326

Unit Model No. _____ Unit Serial No. _____
 Date of Installation _____ Installed by _____
 Name of Owner _____ Address of Installation _____

Outdoor Cooling or Heating-Cooling Product (Units Smaller Than 185,000-Btuh Cooling Capacity) Limited Warranty

ONE-YEAR WARRANTY—This BRYANT HEATING & COOLING SYSTEMS (herein after referred to as 'COMPANY') product is warranted to be free from defects in material and workmanship under normal use and maintenance for a period of one year from the date of original installation whether or not actual use begins on that date. A new or remanufactured part, at the COMPANY'S sole option, to replace any defective part will be provided without charge for the part itself; PROVIDED the defective part is returned to our distributor through a qualified servicing dealer. The replacement part assumes the unused portion of the warranty.

THIS WARRANTY DOES NOT INCLUDE LABOR OR OTHER COSTS incurred for diagnosing, repairing, removing, installing, shipping, servicing or handling of either defective parts or replacement parts or complete unit. Such costs may be covered by a separate warranty provided by the installer.

EXTENDED 4-YEAR WARRANTY ON COMPRESSOR ONLY—During the second through fifth years after the date of original installation, the COMPANY further warrants the compressor against defects in material or workmanship under normal use and maintenance. A new or remanufactured compressor, at the COMPANY'S sole option, will be provided under the same conditions as stated in the ONE-YEAR WARRANTY.

EXTENDED 4-YEAR WARRANTY ON GAS-FIRED HEAT EXCHANGER ONLY—During the second through fifth years after the date of original installation, the COMPANY further warrants the gas-fired heat exchanger against defects in material or workmanship under normal use and maintenance. A new or remanufactured heat exchanger, at the COMPANY'S sole option, will be provided under the same conditions as stated in the ONE-YEAR WARRANTY.

THESE EXTENDED WARRANTIES DO NOT INCLUDE LABOR OR OTHER COSTS incurred for diagnosing, repairing, removing, installing, shipping, servicing or handling of either defective parts or replacement parts.

THESE WARRANTIES APPLY ONLY TO PRODUCTS IN THEIR ORIGINAL INSTALLATION LOCATION AND BECOME VOID UPON REINSTALLATION.

LIMITATIONS OF WARRANTIES—ALL IMPLIED WARRANTIES (INCLUDING IMPLIED WARRANTIES OF MERCHANTABILITY) ARE HEREBY LIMITED IN DURATION TO THE PERIOD FOR WHICH THE LIMITED WARRANTY IS GIVEN. SOME STATES DO NOT ALLOW LIMITATIONS ON HOW LONG AN IMPLIED WARRANTY LASTS, SO THE ABOVE MAY NOT APPLY TO YOU. THE EXPRESSED WARRANTIES MADE IN THIS WARRANTY ARE EXCLUSIVE AND MAY NOT BE ALTERED, ENLARGED, OR CHANGED BY ANY DISTRIBUTOR, DEALER, OR OTHER PERSON WHATSOEVER.

ALL WORK UNDER THE TERMS OF THIS WARRANTY SHALL BE PERFORMED DURING NORMAL WORKING HOURS. ALL REPLACEMENT PARTS, WHETHER NEW OR REMANUFACTURED, ASSUME AS THEIR WARRANTY PERIOD ONLY THE REMAINING TIME PERIOD OF THIS WARRANTY.

THE COMPANY WILL NOT BE RESPONSIBLE FOR:

1. Normal maintenance as outlined in the installation and servicing instructions or owner's manual including coil cleaning, filter cleaning and/or replacement and lubrication.
2. Damage or repairs required as a consequence of faulty installation, misapplication, abuse, improper servicing, unauthorized alteration or improper operation.
3. Failure to start due to voltage conditions, blown fuses, open circuit breakers or other damages due to the inadequacy or interruption of electrical service.
4. Damage as a result of floods, winds, fires, lightning, accidents, corrosive environments or other conditions beyond the control of the COMPANY.
5. Parts not supplied or designated by the COMPANY, or damages resulting from their use.
6. COMPANY products installed outside the continental U.S.A., Alaska, Hawaii and Canada.
7. Electricity or fuel costs or increases in electricity or fuel costs from any reason whatsoever including additional or unusual use of supplemental electric heat.
8. ANY SPECIAL INDIRECT OR CONSEQUENTIAL PROPERTY OR COMMERCIAL DAMAGE OF ANY NATURE WHATSOEVER. Some states do not allow the exclusion of incidental or consequential damages, so the above limitation may not apply to you.

This warranty gives you specific legal rights, and you may also have other rights which vary from state to state.

Catalog No. 5358-002

Effective on product manufactured after July 1, 1987. Supersedes any other warranty certificates supplied with the product.

39004DP177