

## SPECIFICATIONS

- Ultraviolet Germicidal Lamps shall kill bacteria, fungi, and mold that can grow on the cooling coil.
- Unit shall be designed for installation inside of a rooftop HVAC unit.
- Germicidal UV-C energy measured at a distance of 1 meter perpendicular to the center of the lamp shall be greater than  $270 \mu\text{W}/\text{cm}^2 @ 253.7 \text{ nm}$  when measured in a galvanized steel duct with 70°F air moving at 400 FPM.
- Germicidal UV-C energy measured at a distance of 18 inches perpendicular to the center of the lamp shall be greater than  $560 \mu\text{W}/\text{cm}^2 @ 253.7 \text{ nm}$  when measured in a galvanized steel duct with 70°F air moving at 400 FPM.
- Unit shall be complete with stainless steel housing containing: auto-adjusting, variable voltage, high output ballast with a voltage range of 120-277 VAC, 50/60 Hz, high output lamp, fuse protection, and mounting flanges.
- Unit shall be housed completely inside of the HVAC equipment and not require any type of penetration of the equipment casing.
- Unit shall incorporate electrical knock-outs on both ends of the unit to accommodate convenient supply wiring.
- Unit electrical shall not exceed 55 watts.
- Unit shall produce no ozone.
- The unit shall ship complete with mounting hardware to assist in installation.
- Lamp life shall be one year when operated continuously.
- Unit warranty shall be 3 years; the lamp warranty shall be 1 year.
- Unit shall be UL and C-UL classified.
- UV Germicidal Lamp shall be Aprilaire Model 1972, 18" Rooftop Unit, Internal Mount.



#### MODEL 1972 TECHNICAL SPECIFICATIONS

**Housing Dimensions:** 2.77" wide x 3" high x 17" long

**Lamp Length:** 18"

**Electrical Connection:** Field wired (120-277 VAC)

**Electrical Usage:** 55 watts

**Fuse:** 3 amp slow burn, Aprilaire Part #4476

**Ballast:** High output, auto-adjusting to supply voltage (120-277 VAC)

**Lamp:** Aprilaire Part #90

**Ozone Production:** None

**Warranty:** 3 year unit; 1 year lamp

#### INTERNAL COMPONENTS

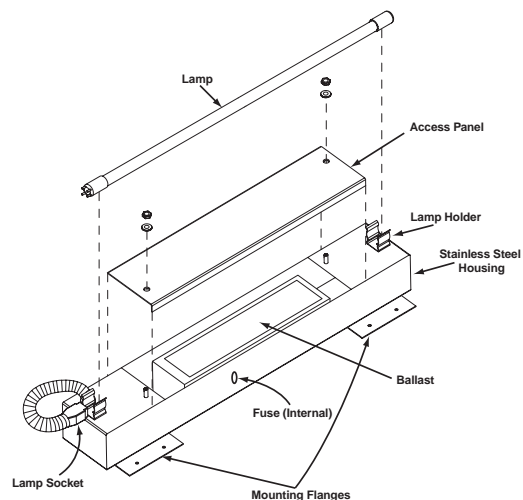



# MODEL 1972 ROOFTOP UV GERMICIDAL LAMP APPLICATION GUIDELINES

## Guidelines for the Required Number of Lamps Based on Coil Area

Coil Area (sq. in.)	Coil Area (sq. ft.)	Model 1972 18" Lamp
750	5.2	1
1000	6.9	2
1250	8.7	2
1500	10.4	2
1750	12.2	3
2000	13.9	3
2250	15.6	3
2500	17.4	4
2750	19.1	4
3000	20.8	4
3250	22.6	5
3500	24.3	5

## Approximate Coil Area Coverage

Coil Area (sq. in.)	Model 1972 18" Lamp
792	
5.5	

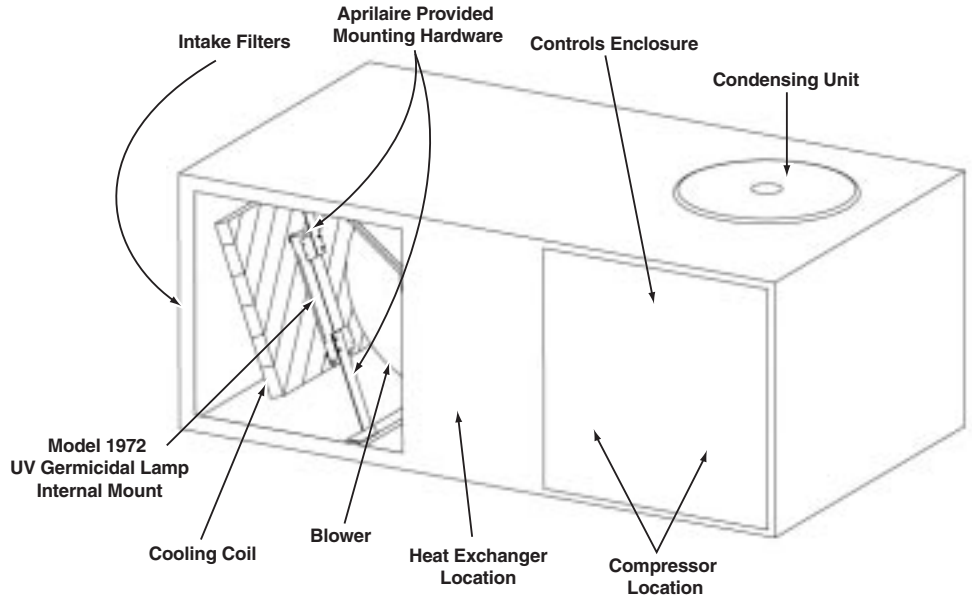

## Notes:

- The tables provided are guidelines only.
- The most important requirement for an effective UV Lamp installation is complete illumination of the coil and drain pan. Install UV Lamps as required to fully illuminate the coil and drain pan.
- The guidelines above are based on the following assumptions:
  - UV Lamps to be installed 3 to 12 inches from coil
  - Coil thickness in the range of 2 to 4 inches

## Intensity vs Distance for a typical UV Germicidal Lamp

Distance from UV Lamp inches	Intensity μW/cm <sup>2</sup>
4	1,400
6	970
12	490
18	270
24	175
36	90
48	50

As the distance between the microorganism and the UVC lamp increases, the intensity decreases. At 12 inches from the lamp, more time is needed to kill a significant amount of bacteria and fungal spores than time allows when microorganisms travel through a duct at 400fpm. (See table.) Aspergillus flavus need to be exposed to UV for 204 seconds; however, in that time they will travel 1358 feet within a HVAC system.

UV Germicidal Light Performance		UVC Dosage to Kill 99.9% of Listed Organism μW-sec/cm <sup>2</sup>	Time for UVC to Kill 99.9% of Listed Organism at a 12" Distance (seconds)	Distance Organism will Travel at 400 fpm Duct Velocity at 99.9% Kill Time (feet)
Name of Microorganism	Type of Microorganism			
Bacillus subtilus	bacteria spores	58,000	119	796
Legionella pneumophillia	bacteria	3,800	8	52
Staphyococcus aureus	bacteria	7,000	14	96
<b>Aspergillus flavus</b>	<b>fungal spores</b>	<b>99,000</b>	<b>204</b>	<b>1358</b>
Aspergillus niger	fungal spores	330,000	679	4527
Mucor racemosus	fungal spores	35,200	72	483
Penicillium expansum	fungal spores	22,000	45	302