

Project: _____
 Architect: _____
 Contractor: _____
 Supplier: _____

Dealer: _____
 Engineer: _____
 Location: _____
 Date: _____

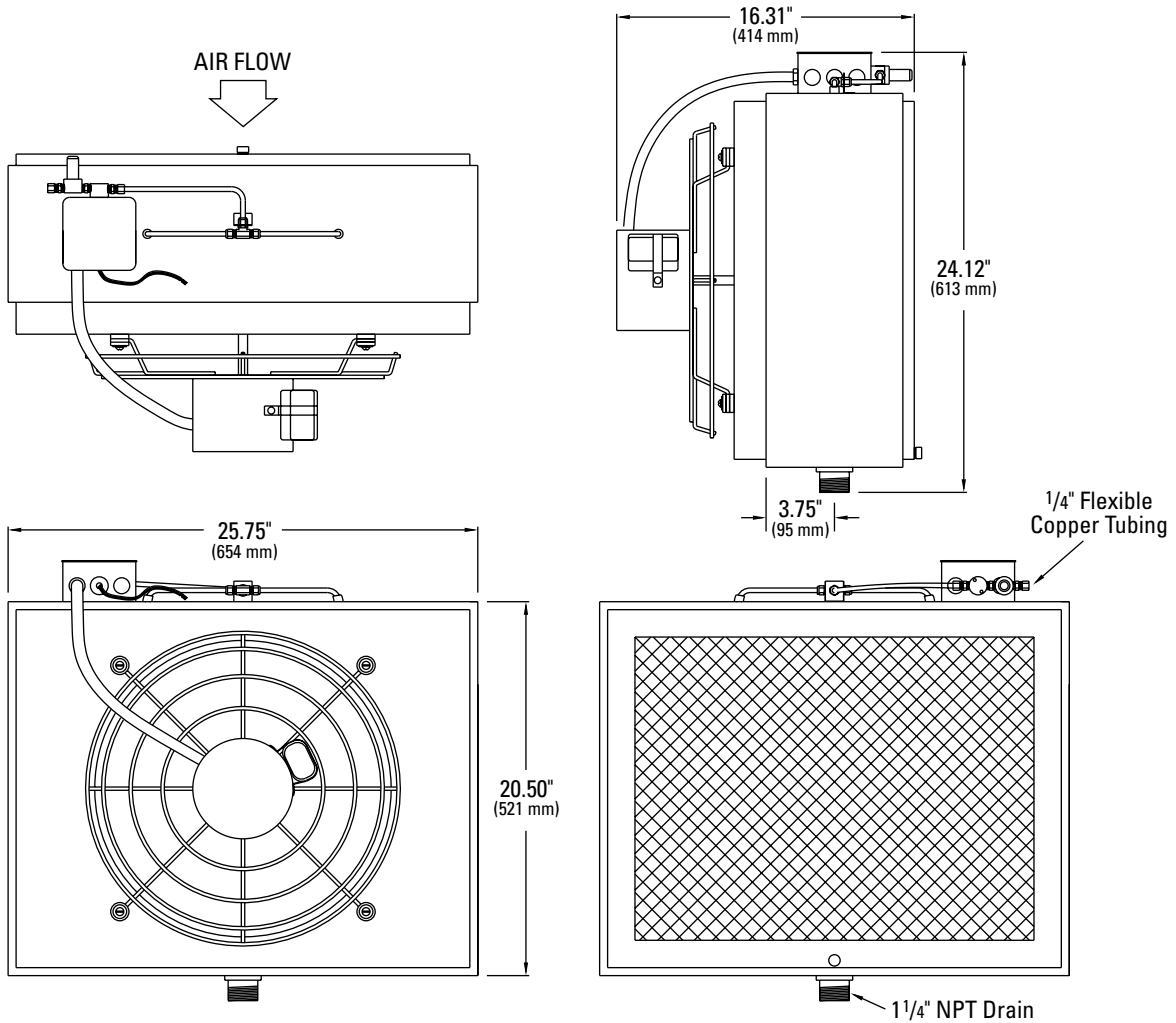

MOUNTING HARDWARE BY OTHERS

Evaporative Capacity:	22 lbs/hr
Water Feed Rate:	25 gph
Required Water Temperature:	140 degrees F
Ambient Temperature Operating Range:	60 degrees F to 120 degrees F
Fan CFM (2 speed):	800/500 CFM

Electrical Characteristics:	
• Water Solenoid Valve/Fan Motor:	120/1/60 VAC
• Control Voltage:	24 VAC
Cabinet Construction:	18GA Steel
Cabinet Finish:	Almond Enamel
Shipping Weight:	60 lbs

The submittal is intended to show general, overall product dimensions and provide guidance for installation clearance. Drawings are not to scale. Ensure submittals are current. Research Products reserves the right to make product changes without notification or obligation.